

Part Number
612.8001



GLX-PLUS

INSTALLATION AND FIELD MAINTENANCE MANUAL

Issue 2, June 1993

TABLE OF CONTENTS

<i>CONTENTS</i>	<i>PAGE</i>
TABLE OF CONTENTS	iii
LIST OF FIGURES	v
FCC REGULATIONS	vii
SAFETY REGULATIONS	ix
LIMITED WARRANTY	x
OVERVIEW	1-1
1. Introduction	1-1
2. Hardware Summary	1-1
3. Installation, Programming, And Maintenance Summary	1-1
4. Features Summary	1-2
SPECIFICATIONS	2-1
1. Introduction	2-2
2. Cabling And The Main Distribution Frame (MDF)	2-2
3. Key Service Unit (KSU)	2-3
4. Station Instruments	2-9
5. Optional System Equipment	2-12
INSTALLATION	3-1
1. Introduction	3-2
2. System Installation Outline	3-2
3. Pre-Installation Checklist	3-4
4. Station Cabling And Terminations	3-6
5. Terminating CO Lines At The MDF	3-12
6. KSU Installation	3-15
7. Station Installation	3-22
8. External Paging Equipment Installation	3-31
9. External Music Source Installation	3-31
10. Battery Back-Up Equipment	3-33
11. Post-Installation Checklist	3-33
FEATURES	4-1
1. Introduction	4-3
2. Feature Keys And Codes	4-3
3. CO Line Features	4-4
4. Protection Against Power Failure	4-5
5. Station Instruments	4-6
6. Signals And Tones	4-14

<i>CONTENTS</i>	<i>PAGE</i>
7. Music-On-Hold And Background Music	4-15
8. Intercom Calls	4-16
9. Outside Calls	4-18
10. Placing Calls On Hold	4-22
11. Call Waiting	4-23
12. Call Transfer	4-24
13. Call Pick-Up (Reverse Transfer)	4-24
14. Paging	4-25
15. Call Forwarding	4-26
16. Privacy Release	4-29
17. Call Privacy Restore (Executive Or GLX-Plus Keysets Only)	4-29
18. Conference Calls (Keysets Only)	4-30
19. Speed Dialing (Keysets Only)	4-32
20. Do-Not-Disturb (Keysets Only)	4-33
21. Redialing (Keysets Only)	4-33
22. Time And Date Display Programming (GLX-Plus Keysets Only)	4-34
23. SMDR Device Station	4-35
24. System Attendant Station	4-43
PROGRAMMING	5-1
1. Introduction	5-1
2. Program Planning Sheets	5-1
3. Outline For Programming New Systems	5-1
4. Initialize The System	5-6
5. Program The System And Station Features	5-8
TROUBLESHOOTING	6-1
1. Introduction	6-1
2. Troubleshooting Checklist	6-1
3. Troubleshooting Charts	6-3
4. Customer Support	6-19
5. Defective Unit Return Policy	6-19
REPLACEMENT PARTS	7-1
1. Introduction	7-1
2. Ordering Procedure	7-1
3. Replacement Parts List	7-1
4. Recommended Spare Parts	7-1
INDEX	I-1

LIST OF FIGURES

<i>NUMBER</i>	<i>TITLE</i>	<i>PAGE</i>
SPECIFICATIONS		
Figure 2-1.	Key Service Unit (KSU)	2-4
Figure 2-2.	Main Control PCB	2-6
Figure 2-3.	Expansion PCB	2-7
Figure 2-4.	Accessory Port Module (APM)	2-8
Figure 2-5.	Standard Keypad	2-14
Figure 2-6.	Executive Keypad	2-15
Figure 2-7.	GLX-Plus Keypad	2-16
INSTALLATION		
Figure 3-1.	Sample System Layout	3-3
Figure 3-2.	Station Modular Jack Assembly Wiring	3-7
Figure 3-3.	Station Cable Terminations At The MDF	3-9
Figure 3-4.	Station Cable Terminations On The Station Block	3-10
Figure 3-5.	CO Line Terminations From RJ14 Jacks	3-13
Figure 3-6.	Modular Jack Assembly Wiring For CO Lines	3-13
Figure 3-7.	CO Line Terminations From An RJ21X Block	3-14
Figure 3-8.	KSU Component Locations	3-15
Figure 3-9.	Install The Expansion PCB	3-17
Figure 3-10.	Install The APM	3-17
Figure 3-11.	Wall Mount The KSU	3-18
Figure 3-12.	KSU Grounding	3-19
Figure 3-13.	KSU Grounding	3-20
Figure 3-14.	Complete The KSU Connections	3-21
Figure 3-15.	GLX-Plus Keypad LCD Installation	3-23
Figure 3-16.	Wall Mount The Keypad	3-26
Figure 3-17.	GLX-Plus Keypad Data Port Module Installation	3-28
Figure 3-18.	LRA Set-Up	3-29
Figure 3-19.	GLX-Plus Keypad Battery Back-Up	3-30
Figure 3-20.	Connect The External Equipment	3-32
FEATURES		
Figure 4-1.	SMDR Report Format	4-37
Figure 4-2.	Database Report Format	4-39

<i>NUMBER</i>	<i>TITLE</i>	<i>PAGE</i>
PROGRAMMING		
Figure 5-1.	Program Planning Sheets	5-2
TROUBLESHOOTING		
Figure 6-1.	Feature Troubleshooting Chart	6-5
Figure 6-2.	Intercom Troubleshooting Chart	6-8
Figure 6-3.	CO Line Troubleshooting Chart	6-9
Figure 6-4.	Keypad Troubleshooting Chart	6-11
Figure 6-5.	Single-Line Set Troubleshooting Chart	6-14
Figure 6-6.	System Troubleshooting Chart	6-16
REPLACEMENT PARTS		
Figure 7-1.	Replacement Parts	7-1
Figure 7-2.	Recommended Spare Parts	7-2

FCC REGULATIONS

IMPORTANT:

1. This equipment complies with Part 68 of FCC rules. On the side of the KSU is a label that contains, among other information, the FCC registration number and ringer equivalence number (REN) for this equipment. Customers connecting this equipment to the telephone network shall, before such connection is made, give notice to the telephone company of the particular line(s) to which such connection is to be made, and shall provide the telephone company with the following information:

- Complies with Part 68 of FCC rules
- FCC registration no.: BE287V-15678-KF-E
- Quantities and USOC numbers of required interface jacks: RJ14 (C or W) or RJ21X
- Sequence in which lines are to be connected
- Ringer equivalence number (REN): 0.2A

NOTE: The REN is used to determine the quantity of devices which may be connected to the telephone line. Excessive RENs on the telephone line may result in the devices not ringing in response to an incoming call. In most, but not all areas, the sum of the RENs should not exceed five (5.0). To be certain of the number of devices that may be connected to the line, as determined by the total RENs, contact the telephone company to determine the maximum REN for the calling area.

- Facility interface code (FIC) by position: 02LS2

The telephone company should also be given notice upon final disconnection of this equipment from the particular line(s).

It is also the responsibility of the customer to provide the telephone company with registration numbers of any other devices which are configured for connection to the telephone network.

2. This equipment cannot be used on public coin service provided by the telephone company. Connection to party line service is subject to state tariffs. (Contact the state public utility commission, public service commission, or corporation commission for information.)
3. If this equipment causes harm to the telephone network, the telephone company will notify the customer in advance that service may be temporarily

discontinued. But if advance notice is not practical, the telephone company will notify the customer as soon as possible. Also, the customer will be advised of the right to file a complaint with the FCC, if necessary.

4. The telephone company may make changes in its facilities, equipment, operations, or procedures which may affect the operation of this equipment. If so, the customer shall be given advance notice so that any necessary modifications can be made in order to maintain uninterrupted service.
5. If trouble is experienced with this equipment, contact a local authorized factory service representative for repairs and/or warranty information. The customer, users, and unauthorized technicians should not repair, make adjustments to, or attempt to service this equipment in any way.

In the event of trouble with the telephone line(s), this equipment must be disconnected from the telephone line(s). If trouble ceases, the equipment must be repaired by an authorized factory service representative. If the trouble continues to occur with the equipment disconnected, the telephone company should be notified that they have a problem. If this is the case, repairs or adjustments made by the telephone company will be made at their expense.

NOTICE

THE TELEPHONE INSTRUMENTS SPECIFICALLY DESIGNED FOR THIS SYSTEM HAVE HEARING-AID COMPATIBLE HANDSETS THAT ARE IN COMPLIANCE WITH SECTION 68.316 OF THE FCC RULES.

WARNING:

This equipment generates and uses radio frequency energy and if not installed and used properly, that is, in strict accordance with the manufacturer's instructions, may cause interference to radio and television reception. It has been type tested and found to comply with the limits for a Class A computing device in accordance with the specifications in Subpart J of Part 15 of FCC Rule. Operation of this equipment in a residential area may cause unacceptable interference to radio and TV reception requiring the operator to take whatever steps are necessary to correct the interference. However, there is no guarantee that interference will not occur in a particular installation. If this equipment does cause interference to radio or television reception, which can be determined by turning the equipment off and on, the user is encouraged to try to correct the interference by one or more of the following measures:

- Reorient the receiving antenna
- Relocate the KSU with respect to the receiver
- Check that the KSU and receiver are not on the same circuit; the KSU must be powered from an isolated, dedicated AC outlet

If necessary, the user should consult the dealer or an experienced radio/television technician for additional suggestions. The user may find the following booklet

prepared by the Federal Communications Commission helpful:

“How to Identify and Resolve Radio-TV Interference Problems”

This booklet is available from the U.S. Government Printing Office, Washington, D.C. 20402, Stock No. 004-000-00398-5.

If RFI problems persist, refer to the TROUBLE-SHOOTING section of this manual and, if necessary, contact Inter-Tel Customer Support.

SAFETY REGULATIONS

The GLX-Plus System is listed by Underwriters Laboratories Inc. (UL) as meeting the Product Safety Requirements of UL 1459, Standard for Telephone Equipment. UL is approved by the Occupational Health and Safety Administration (OSHA) as a Nationally Recognized Testing Laboratory (NRTL). *Before installation, also check the local electrical codes for important information concerning the installation of telephone and electronic equipment.*

The following safety information is reprinted from UL 1459, a product safety specification governing telephone equipment.

IMPORTANT SAFETY INSTRUCTIONS

When using your telephone equipment, basic safety precautions should always be followed to reduce the risk of fire, electric shock, and injury to persons, including the following:

1. Read and understand all instructions.
2. Follow all warnings and instructions marked on the product.
3. Unplug this product from the wall outlet before cleaning. Do not use liquid cleaners or aerosol cleaners. Use a damp cloth for cleaning.
4. Do not use this product near water (for example, in a wet basement).
5. Do not place this product on an unstable cart, stand, or table. The product may fall, causing serious damage to the product.
6. Slots and openings in the cabinet and the back or bottom are provided for ventilation, to protect it from overheating; these openings must not be blocked or covered. This product should never be placed near or over a radiator or heat register. This product should not be placed in a built-in installation unless proper ventilation is provided.
7. This product should be operated only from the type of power source indicated in the manual. If you are not sure of the type of power source to your building, consult your dealer or local power company.
8. This product is equipped with a three-wire grounding type plug, a plug having a third (grounding) pin. This plug will only fit into a grounding type power outlet. This is a safety feature. If you are unable to insert the plug into the outlet, contact your electrician to replace your obsolete outlet. Do not defeat the safety purpose of the grounding type plug.
9. Do not allow anything to rest on the power cord. Do not locate this product where the cord will be abused by persons walking on it.
10. Do not use an extension cord with this product's AC power cord. The AC outlet for this product should not be used for any other electrical equipment.
11. Never push objects of any kind into this product through cabinet slots as they may touch dangerous voltage points or short out parts that could result in a risk of fire or electric shock. Never spill liquid of any kind on the product.
12. To reduce the risk of electric shock, do not disassemble this product, but take it to a qualified serviceman when some service or repair work is required. Opening or removing covers may expose you to dangerous voltages or other risks. Incorrect reassembly can cause electric shock when the product is subsequently used.
13. Unplug this product from the wall outlet and refer servicing to qualified service personnel under the following conditions:
 - A. When the power supply cord or plug is damaged or frayed.
 - B. If liquid has been spilled into the product.
 - C. If the product has been exposed to rain or water.
 - D. If the product does not operate normally by following the operating instructions. Adjust only those controls that are covered by the operating instructions because improper adjustment of other controls may result in damage and will often require extensive work by a qualified technician to restore the product to normal operation.
 - E. If the product has been dropped or the cabinet has been damaged.
 - F. If the product exhibits a distinct change in performance.
14. Avoid using a telephone (other than a cordless type) during an electrical storm. There may be a remote risk of electric shock from lightning.
15. Do not use the telephone to report a gas leak in the vicinity of the leak.

SAVE THESE
INSTRUCTIONS

LIMITED WARRANTY

For a period of one (1) year from the date of shipment to Buyer, INTER-TEL warrants the Equipment (except for fuses and lamps) to be free from defects in material, workmanship, or both, and to comply with specifications for the Equipment, as set forth in the *Installation and Field Maintenance Manual*. Buyer's sole and exclusive remedy for breach of this Limited Warranty shall be to have the defective Equipment (or parts) repaired or replaced at INTER-TEL's option. Shipping costs incurred returning warranty work to INTER-TEL shall be paid for by the Buyer. *This Limited Warranty extends only to the Buyer, not to any customer, user, or third party.* This Limited Warranty does not apply to Equipment (or parts) damaged by improper handling, normal wear and tear, accidents, lightning damage, negligence, or improper use or maintenance, and does not apply to Equipment altered without authorization by INTER-TEL. This Limited Warranty does not extend to any claims, suits, damages, liabilities, costs, and expenses arising from any act, action, or inaction of Buyer. Although the Moss-Magnuson Act should not apply, in the event that it is held to apply by a court of competent jurisdiction, the implied warranty of fitness for a particular purpose shall extend for the one-year (1-year) period from the date that the Equipment was shipped to the Buyer.

THIS WARRANTY IS IN LIEU OF AND EXCLUDES ALL OTHER WARRANTIES, EXPRESS OR IMPLIED, INCLUDING, BUT NOT LIMITED TO, THE IMPLIED WARRANTY OF MERCHANTABILITY OR FITNESS FOR A PARTICULAR PURPOSE. THERE ARE NO WARRANTIES WHICH EXTEND BEYOND THIS LIMITED WARRANTY. IN NO EVENT SHALL INTER-TEL BE LIABLE FOR LOSS OF ANTICIPATED PROFITS, INCIDENTAL OR CONSEQUENTIAL DAMAGES, LOSS OF TIME OR OTHER LOSSES INCURRED BY BUYER IN CONNECTION WITH THE PURPOSE, POSSESSION, OPERATION, OR USE OF THE EQUIPMENT, SUCH CLAIMS BEING EXPRESSLY WAIVED BY THE INSTALLING COMPANY.

For complete information on returning equipment, refer to the current Inter-Tel Incorporated *Material Return Policy* (document part number 835.1065). This document includes specific information on the following subjects: warranty, procedures to follow when returning equipment, equipment damaged in shipment, insurance, repair policy, and advance replacement policy.

OVERVIEW

<i>CONTENTS</i>	<i>PAGE</i>
1. Introduction	1-1
2. Hardware Summary	1-1
3. Installation, Programming, And Maintenance Summary	1-1
4. Features Summary	1-2
A. System Features	1-2
B. Keypad Features	1-2
C. Single-Line Features	1-3
D. Attendant Features	1-3
E. Maximum Capacities	1-3

1. INTRODUCTION

1.1 The Inter-Tel GLX-Plus System is a versatile, electronic key telephone system designed to meet the needs of small businesses. The system is easy to install and maintain, and it offers a variety of features usually found on more expensive systems. Highlights of the system's design include:

- Advanced microprocessor technology
- Flexible programming to customize many system and station features
- Capacity for up to six central office (CO) lines, 12 keysets (or 10 keysets and two single-line devices), and two private intercom channels

2. HARDWARE SUMMARY

2.1 The SPECIFICATIONS section of this manual explains environmental requirements of the system, describes the hardware, and gives pre-installation information. The hardware descriptions include: Key Service Unit (KSU), station instruments, and additional equipment needed for optional features.

3. INSTALLATION, PROGRAMMING, AND MAINTENANCE SUMMARY

3.1 The modular design and self-diagnostic capabilities of the system facilitate installation and repair with minimal down-time. Strict quality control standards for manufacturing and thorough field testing provide the system with the reliability demanded by today's high-technology market.

3.2 The INSTALLATION section contains instructions for assembling the main distribution frame (MDF) and for installing the KSU, station instruments, and other optional hardware.

3.3 The PROGRAMMING section describes the procedures for programming the system features. After the system is installed, the flexible software allows the database to be customized to meet the customer's needs. All programming is performed through the system's keysets.

3.4 The TROUBLESHOOTING section gives instructions for correcting system problems and replacing defective parts. Part numbers and a recommended inventory of spare parts are listed in the REPLACE-MENT PARTS section.

4. FEATURES SUMMARY

4.1 System, keyset, single-line set, and attendant features are listed below. *Those features marked with an asterisk (*) require additional equipment.* For complete descriptions and operating instructions, refer to the SPECIFICATIONS and FEATURES sections of this manual.

A. SYSTEM FEATURES

Hardware and General System Features

- Flexible incoming ring assignments (alternate point answering)
- Flexible night ringing arrangement (night ring mode)
- Database battery back-up
- Variable system timers
- * Optional external music source
- * Optional external paging equipment
- * Optional system battery back-up
- * Optional repeaters for amplified CO lines
- * Optional doorbox
- * Optional voice mail system or answering machine
- * Optional facsimile machine
- * Optional station message detail recording (SMDR) adapter and output device (for printing station call data and database reports)

System Organization and Record Keeping Features

- Internal and external paging zones
- System alarm display and reporting
- * Optional SMDR and database reports

Outside Call Features

- Dual-tone multi-frequency (DTMF) or dial-pulse signalling
- CO line restriction
- Toll restriction
- Programmable CO hookflash
- Automatic recall timers
- Day and night modes of operation
- Busy CO line callback (queue)

General Station Features

- Outside call waiting
- Privacy release

- * Music-on-hold
- * Internal and external paging
- Private intercom calls
- Intercom camp-on and call waiting
- Night ring answer

B. KEYSET FEATURES

- Six line keys
- Feature keys (six on Standard Keysets, 12 on Executive Keysets and GLX-Plus Keysets)
- LED indications
- Direction station selection/busy lamp field (DSS/BLF) keys on Executive and GLX-Plus Keysets

- Volume controls

NOTE: GLX-Plus Keysets, which are equipped with audio integrated module circuitry, allow the users to individually control voice and tone volume levels for intercom calls, outside calls, background music, etc.

- Immediate ringing
- Off-hook ringing
- Ring intercom first
- * Handset amplifier compatible
- Integrated speakerphone
- Handsfree answering of intercom calls
- Individual hold on the Executive and GLX-Plus Keysets
- Call transfer from the Executive and GLX-Plus Keysets
- Line key skipping
- On-hook dialing
- DSS/BLF key skipping on the Executive and GLX-Plus Keysets
- * Headset compatible
- * Data device and SMDR interface on the Executive and GLX-Plus Keysets
- * Background music
- Call privacy enable
- Direct line key selection
- System/station speed dialing
- Last number redial
- System hold
- Conference calls
- Do-not-disturb
- Call forwarding (internal and to the public network)

C. SINGLE-LINE FEATURES

- Call forwarding (internal only)
- Call waiting tones enable/disable
- Reverse transfer
- Programmable single-line hookflash
- Programmable intercom ring cadence (standard or extended)
- Programmable audio path attenuation on a port-by-port basis (0dB or 3db pad)

D. ATTENDANT FEATURES

- Responds to "0" as an intercom number
- Receives attendant recalls
- System feature programming
- System night ring mode programming
- System speed-dial number programming

E. MAXIMUM CAPACITIES

4.2 Some of the features have maximum capacities that are dependent on the availability of system chan-

nels and/or circuits. The features with such capacities are listed in the following table.

FEATURE	CAPACITY
Paging zones	
Internal	1
External	1
Conference calls	
Parties per conference	5
Simultaneous conferences	2
System speed dialing	
Numbers per system	30
Digits per number	32
Station speed dialing	
Numbers per station	9
Digits per entry	32
Redial numbers per station	1
Digits per number	32
Busy line callback (queue) requests per station	6
Stations camped on to a station	1
Stations camped on to a line	12

SPECIFICATIONS

<i>CONTENTS</i>	<i>PAGE</i>
1. Introduction	2-1
2. Cabling And The Main Distribution Frame (MDF)	2-2
A. Station Connections	2-2
B. Central Office (CO) Line Connections	2-2
3. Key Service Unit (KSU)	2-3
A. KSU Description	2-3
B. Environmental Requirements	2-3
C. System Power Supply	2-5
D. Main Control Printed Circuit Board (PCB)	2-5
E. Expansion PCB	2-5
F. Accessory Port Module (APM)	2-5
4. Station Instruments	2-9
A. Maximum Capacities	2-9
B. Keysets	2-9
C. Single-Line Sets	2-11
5. Optional System Equipment	2-12
A. System Battery Back-up	2-12
B. Repeater Application For Amplified CO Lines	2-12
C. Doorbox	2-12
D. Answering Machine Or Voice Mail Unit	2-12
E. FAX Machine	2-13
F. Station Message Detail Recording (SMDR) Adapter And Output Device ..	2-13

1. INTRODUCTION

1.1 This section of the manual describes the following GLX-Plus System hardware:

- Cabling and the Main Distribution Frame (MDF)
- Key Service Unit (KSU)
- Station Instruments
- Optional Equipment

1.2 The GLX-Plus System has a basic capacity for three CO lines and eight keysets. Installing the optional Expansion printed circuit board (PCB) increases the system capacity to six CO lines and 12 keysets. Or, installing the optional Accessory Port Module (APM) increases the system capacity to six CO lines, 10 keysets, and two single-line devices.

1.3 A variety of station instruments can be used on the GLX-Plus System, including:

- Standard Keysets
- Executive Keysets
- GLX-Plus Keysets (display and non-display)
- Industry-Standard Single-Line, Dual-Tone Multi-Frequency (DTMF) Sets

1.4 The following optional system equipment can also be installed:

- External music source; refer to page 2-3.
- External paging equipment; refer to page 2-3.
- Surge/spike protector; refer to page 2-5.
- System battery back-up; refer to page 2-12.
- CO repeater application; refer to page 2-12.
- Doorbox; refer to page 2-12.
- Voice mail or answering machine; refer to page 2-12.

- Facsimile machine; refer to page 2-13.
- Station Message Detail Recording (SMDR) Adapter and output device, refer to page 2-13.

2. CABLING AND THE MAIN DISTRIBUTION FRAME (MDF)

2.1 Connections between the KSU, CO lines, and station instruments are made at the MDF. The MDF requires at least a 3 × 4-foot (0.9 × 1.2-meter), ¾-inch plywood backboard. This will allow room to mount the KSU, connecting blocks, modular jack assemblies, and any optional peripheral equipment.

A. STATION CONNECTIONS

2.2 Two-pair twisted cable is run in a star (home-run) configuration from the KSU to each station location. All station cables are terminated on the 66M1-50-type connecting block that is mounted on the MDF backboard. The other end of each station cable is terminated on a four-conductor modular jack assembly at the station location. As an interface between the station block and the KSU, one end of a 25-pair cable is terminated on the block; the other end has a female amphenol-type connector that attaches to the male connector on the KSU. Finally, bridging clips are installed to complete the connections on the block.

NOTE: To avoid possible ringing crosstalk, be sure to locate the station terminal block close to the KSU (the 25-pair cable between the block and the KSU should be less than three feet in length), and do not run the station cabling for single-line devices in parallel with the station cabling for keysets.

B. CENTRAL OFFICE (CO) LINE CONNECTIONS

2.3 As specified in FCC Regulations, the CO lines should be terminated on telephone company RJ14 (C or W) jacks or on an RJ21X block. Three methods of terminating CO lines are provided in the INSTALLATION section, along with complete details about necessary supplies and procedures. The three methods are as follows:

- **If the CO lines are terminated on RJ14 jacks mounted near the MDF:** Using two-pair mod-to-mod line cords, every two CO lines are connected directly to the corresponding CO jacks on the KSU.

CAUTION

If the above installation method is used, the lightning protection procedures outlined in paragraph 2.4 cannot be followed. For lightning protection capability, use one of the following installation methods instead.

- **If the CO lines are terminated on RJ14 jacks mounted away from the MDF:** Using two-pair mod-to-mod line cords, every two CO lines are first terminated from the RJ14 jacks onto four-conductor modular jack assemblies mounted next to the RJ14 jacks. Then, using standard two-pair cable, the CO lines are extended to modular jack assemblies mounted on the MDF backboard. Finally, two-pair mod-to-mod line cords complete the connection from the modular jack assemblies to the corresponding CO jacks on the KSU. For a diagram of this method, see page 3-13.

- **If the CO lines are terminated on an RJ21X block:** A 25-pair cable terminates the CO lines from the RJ21X block onto a 66M1-50-type connecting block on the MDF backboard. Then, for every two CO lines, two-pair cable (or cross-connect cable) is connected from the CO block to four-conductor modular jack assemblies mounted next to the KSU. Finally, two-pair mod-to-mod line cords complete the connection from the modular jack assemblies to the corresponding CO jacks on the KSU. For a diagram of this method, refer to page 3-14.

2.4 It is recommended that gas discharge tubes with silicon avalanche suppressors be installed on all CO lines for lightning protection. Also, in areas with frequent occurrences of lightning, it is recommended that the cable between the telephone company termination and the gas discharge tubes be at least 75 feet long (the cable may be coiled up if desired).

2.5 The following CO line characteristics may be requested by the telephone company before the system is installed.

CHARACTERISTICS

Loss from:	
CO to keyset	0dB (@1kHz, 0 ft.)
CO to single-line set	0dB (@1kHz, 0 ft.)
CO to CO	0dB (@1kHz, 0 ft.)
Ringer equivalence	0.2A
Ringing voltage	40VRMS minimum

PROTECTION

Tip-to-ring	250VRMS transient
-------------	-------------------

3. KEY SERVICE UNIT (KSU)

A. KSU DESCRIPTION

3.1 The KSU is a compact, wall-mounted unit that houses the system power supply, the Main Control PCB, and the optional Expansion PCB or the optional APM. The KSU performs all control and switching activities for the system, including: detecting incoming CO calls, storing speed-dial numbers, processing data-controlled features, and controlling the interaction between keysets, single-line sets, CO lines, and intercom channels. Refer to the next page for a photograph of the KSU.

3.2 The system is a microprocessor-controlled, space-division switching system. The 14 audio channels include:

CO lines	6
Intercom	2
Music-on-hold	2
External page	1
Conference	2
Background music	1

3.3 The KSU dimensions and weight are:

Height	15 in. (38.1 cm.)
Width	11.5 in. (29.2 cm.)
Depth	4.25 in. (10.8 cm.)
Weight	12 lb. (5.4 kg.)

3.4 Inputs and outputs on the KSU side panels are as follows:

- Three CO line modular jacks (CO lines 1-2, 3-4, 5-6) serve as inputs for two CO lines each.
- The male amphenol-type connector (STN 1-12) serves as the input for all keysets and single-line devices.
- The external paging jack (E-PAGE), a 1/8-inch mini-phone jack, is the output to a customer-provided

paging amplifier. For installation information, refer to page 3-31.

- The music jack (an RCA-type phono jack) is the input for a customer-provided external music source, such as a radio, tape player, etc. For installation information, refer to page 3-31.

NOTE: Current KSUs have a battery back-up jack (BATT 30V) that is the input for a customer-provided battery charger and/or 30V battery pack. This jack is being removed on future models. In place of the battery back-up jack, Inter-Tel recommends using an uninterruptible power supply (UPS) or standby power supply (SPS) unit. For additional specifications and installation information, refer to pages 2-12 and 3-33.

B. ENVIRONMENTAL REQUIREMENTS

3.5 The KSU and the station instruments require the following environmental conditions:

REQUIREMENTS	IN OPERATION	IN STORAGE
Temperature (KSU)	32° to 80° F 0° to 26.5° C	4° to 185° F -15.5° to 85° C
Temperature (Station Instruments)	32° to 113° F 0° to 45° C	-40° to 185° F -40° to 85° C
Relative Humidity (Non-Condensing)	20% to 85%	0% to 85%
Altitude	Up to 10,000 ft. (3,048 m.)	Up to 40,000 ft. (12,192 m.)

NOTE: It is recommended that the maximum operating temperature (as listed above) *never* be exceeded. Therefore, when installing the KSU and station instruments, allow a sufficient margin for error in case of air conditioning failure, routine mechanical maintenance, plant shutdown, etc. As a general guideline, if the conditions are suitable for office personnel, they are also suitable for all equipment and station instrument operation. A properly controlled environment will help to extend the operating life of the equipment.

FIGURE 2-1. KEY SERVICE UNIT (KSU)

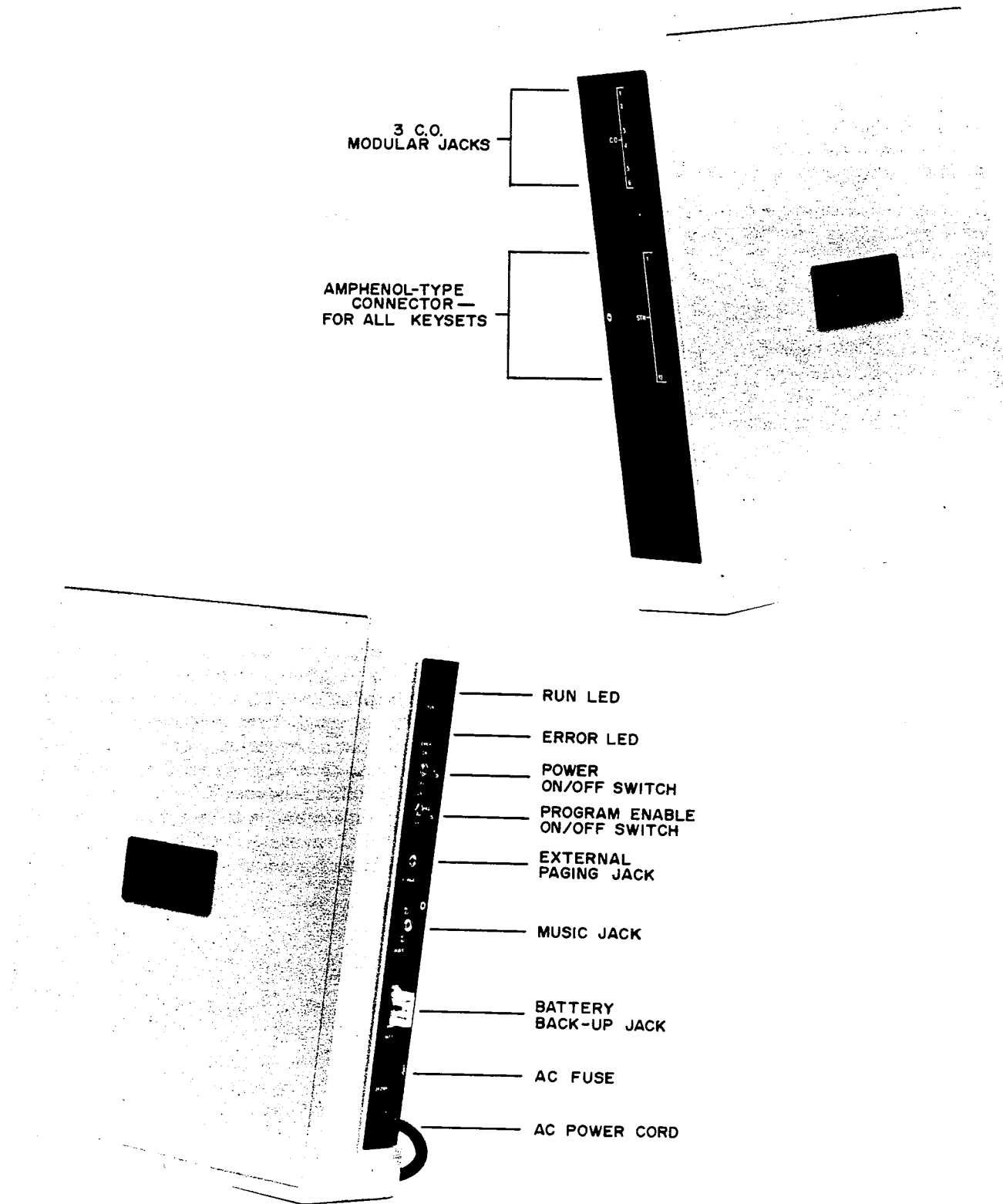

C. SYSTEM POWER SUPPLY

3.6 The KSU power supply, which converts the AC input voltage to the DC voltages required by the system, *must* have an isolated, dedicated, 105–125VAC, 15A, 57–63Hz, single-phase commercial power source (for more details, refer to the first NOTE on page 3–4 in INSTALLATION).

3.7 A 2A, 250V, slow-blow fuse protects the system from excessive current draw. For continued system protection, replace only with a fuse of the same type and rating.

Voltage Surge and Spike Protection

3.8 To reduce the effects of AC voltage surges and spikes that may cause system malfunctions, false logic, and/or damage to the electronic components, a surge/spike protector is recommended. Check the manufacturer's specifications to ensure that the surge/spike protector meets the following requirements:

- Clamp voltage transients at 300VDC within 5 nanoseconds when exposed to waveforms as described in the ANSI/IEEE Standard C62.41–1980 (IEEE 587).
- Reduces RFI/EMI noise by at least 20dB at frequencies between 5kHz and 30MHz.

D. MAIN CONTROL PRINTED CIRCUIT BOARD (PCB)

3.9 The Main Control PCB contains the main controlling microprocessor and its associated control logic and memory circuitry, a battery for database protection, system timers, circuitry for music-on-hold and external paging, and circuitry for three CO lines and eight keysets. Refer to Figure 2–2 on the next page for a photograph of the PCB.

NOTE: With the current software, there is only one ROM (UB4) on the Main Control PCB.

3.10 The main Control PCB functions under the control of a program that is activated when the KSU is powered up. The PCB is in constant communication with the microprocessor in each keyset.

3.11 There are 8k bytes of random-access memory (RAM) and a minimum of 16k bytes of read-only memory (ROM) for use by the Main Control PCB. The software code for the main generic program is stored in the non-volatile ROM memory, and the programmed database and speed-dial numbers are stored in the RAM memory.

3.12 The RAM memory is protected by a lithium battery. The battery will protect the programmed database until the accumulated system downtime exceeds one year. Under normal system use, the battery should last approximately 10 years. The PCB is shipped with a piece of paper between the battery and the battery clip to prevent any discharge until the KSU is installed.

3.13 When the system is initialized, all CO lines are configured for DTMF signalling. If necessary, some or all of the lines can be reprogrammed for dial-pulse signalling through database programming.

3.14 If a customer-provided music source is installed, the music-on-hold circuitry provides two channels of music for two CO lines on hold. Refer to page 4–15 for more information. In addition, the music source can be heard through keyset speakers as background music, and camped-on intercom callers hear the music while waiting. The music-on-hold circuitry automatically holds the volume to a predetermined level that is slightly lower than normal voice volume, as required by FCC regulations. The optimum input level is 1.0VRMS (0dB).

3.15 There are three 1A, 250V, fast-acting fuses on the PCB to protect the KSU and keysets from excessive current flow. For continued protection, replace only with fuses of the same type and rating.

E. EXPANSION PCB

3.16 Circuitry for an additional three CO lines and four keysets can be added to the Main Control PCB to expand the system's capacity to six CO lines and 12 keysets. The circuitry is contained on an optional Expansion PCB that plugs into the Main Control PCB. Refer to Figure 2–3 on page 2–7 for a photograph of the PCB.

F. ACCESSORY PORT MODULE (APM)

3.17 Circuitry for an additional three CO lines, two keysets, and two AC-ringing single-line devices can be added to the Main Control PCB to expand the system's capacity to six CO lines, 10 keysets, and two single-line devices. The circuitry is contained on an optional APM that plugs into the Main Control PCB. Refer to Figure 2–4 on page 2–8 for a drawing of the APM.

NOTE: The APM is supported only on KSUs equipped with the current 827.4012 software. Also, only one Expansion PCB *or* only one APM can be added to the KSU. It is not possible to install both boards.

FIGURE 2-2. MAIN CONTROL PCB

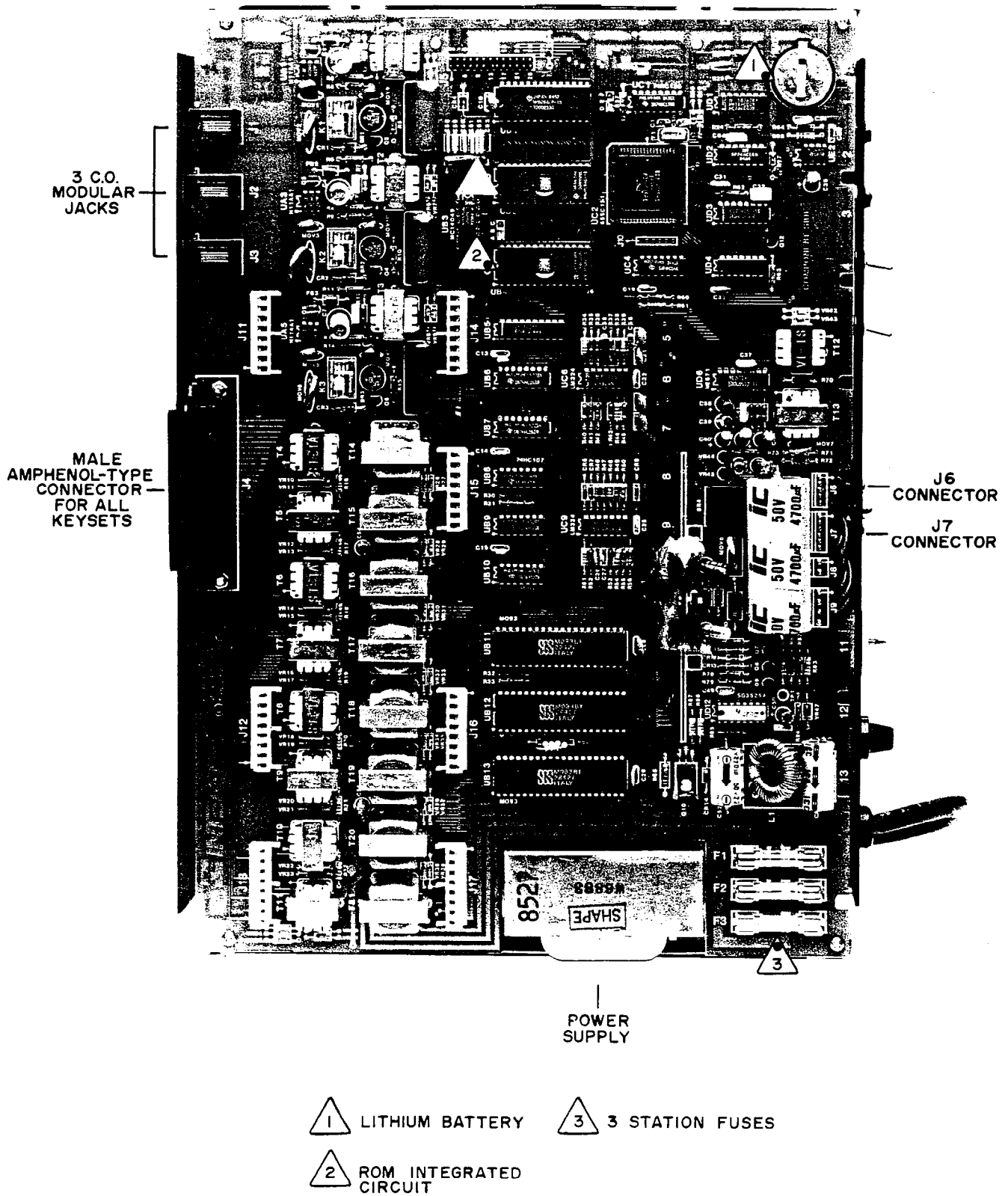

FIGURE 2-3. EXPANSION PCB

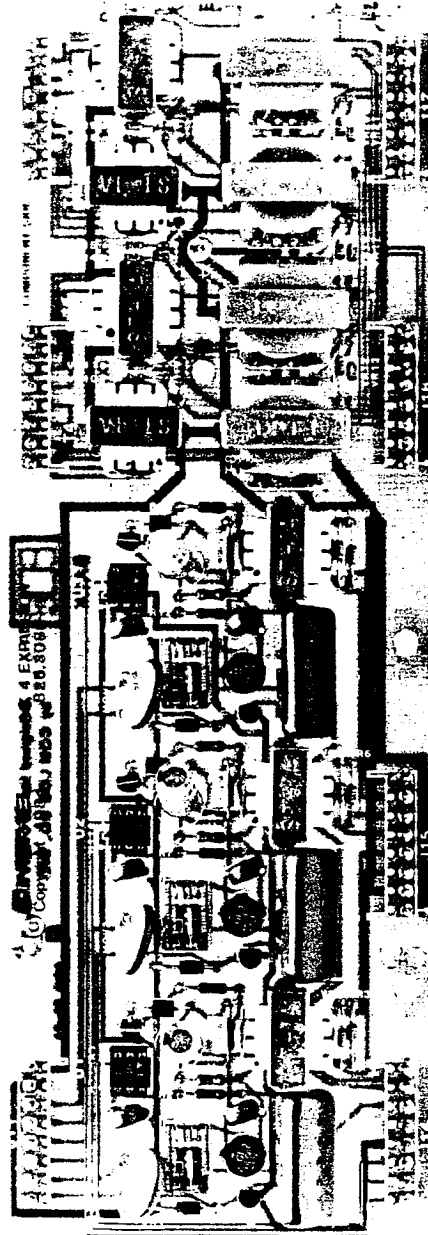
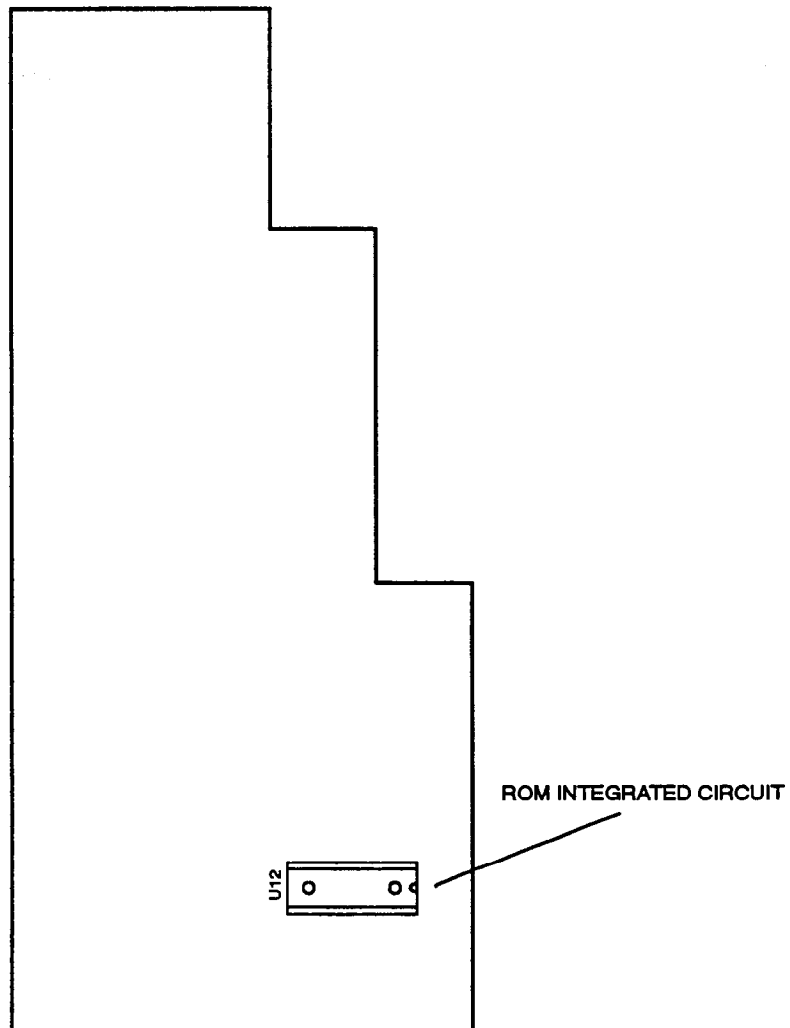

FIGURE 2-4. ACCESSORY PORT MODULE (APM)



4. STATION INSTRUMENTS

A. MAXIMUM CAPACITIES

4.1 The system capacity for stations is as follows:

Total Station Instruments	12
Keysets	1-12
Single-Line Sets	0-2

B. KEYSETS

4.2 The following keyset models are available:

- Standard Keyset
- Executive Keyset
- GLX-Plus Keyset (display and non-display)

NOTE: The GLX-Plus Keyset is supported only on KSUs equipped with the current 827.4012 software.

4.3 For illustrations of the keysets (showing feature keys, CO line keys, and DSS/BLF keys), refer to the drawings beginning on page 2-14.

4.4 The Standard and Executive Keyset dimensions are:

Height	3.5 in. (8.9 cm.)
Width	7.5 in. (19.0 cm.)
Depth	9.0 in. (22.9 cm.)
Weight	2.5 lb. (1.1 kg.)

4.5 The GLX-Plus Keyset dimensions are:

Height	3.8 in. (9.7 cm.)
Width	7.0 in. (17.8 cm.)
Length	9.5 in. (24.1 cm.)
Weight	2.5 lb. (1.1 kg.)

4.6 All keysets have the following design features:

- 12-key pushbutton keypad
- Feature keys (6 on Standard Keysets, 12 on Executive Keysets, and 12 on GLX-Plus Keysets)
- Integrated (built-in) speakerphone
- Ring and voice volume controls
- Slide-out directory card
- Reversible baseplate for wall mounting
- Hearing aid-compatible (HAC) handset

NOTE: GLX-Plus Keysets and handsets have been designed using "electret" microphone circuitry, rather than the "dynamic" microphone circuitry used on Standard and Executive Keysets. Both types of keysets can be used together on the GLX-Plus System. However, if a

dynamic handset is attached to an electret keyset, the handset transmit levels will be noticeably lower. If an electret handset is attached to a dynamic keyset, the handset will not transmit.

4.7 Besides the features listed after paragraph 4.6, Executive Keysets and GLX-Plus Keysets have the following additional features:

- 12 Direct Station Selection/Busy Lamp Field (DSS/BLF) keys with light-emitting diode (LED) indicators
- Can be equipped with *either* a data device (such as a personal computer equipped with a modem) *or* a loud ringing adapter (LRA) and an external signaling device (such as a loud bell, horn, flashing light, etc.)
- Can be equipped with an SMDR Adapter and output device for generating various system reports
- VOL UP and VOL DN keys allow the user to individually control speakerphone, handset, and ring tone volume levels (GLX-Plus Keysets only)
- Self-test feature for testing keyset functions (GLX-Plus Keysets only)

4.8 The DSS/BLF keys on the Executive and GLX-Plus Keysets provide one-key access to any station. The lamps under the DSS/BLF keys create the busy lamp field, which indicates the status of each keyset (idle, busy, call recalling from hold, forwarding calls, in do-not-disturb, in lock-out) by different flash rates.

Integrated Speakerphone

4.9 A built-in, integrated speakerphone is standard in all keysets. It allows users to place and receive outside calls and intercom calls without lifting the handset. Once a call is connected, the keyset user may speak handsfree over the speakerphone or lift the handset to speak privately. When using the handset, the user may switch to the speakerphone by pressing the ON/OFF key and replacing the handset. If enabled, pages and/or background music may be broadcast over the speaker when the phone is not being used.

Optional Liquid Crystal Display (LCD)

4.10 Each GLX-Plus Display Keyset has a liquid crystal display (LCD) with one 16-character line. The display helps the user to process calls more efficiently. There are display messages for date and time, numbers dialed, incoming calls, station and system status, system alarms, and programming. These displays are indicated throughout the FEATURES section of the manual. GLX-Plus Non-Display Keysets can be converted to display sets by installing an optional LCD Unit (part

number 828.1188). Other keyset models cannot be equipped with displays.

Optional Headsets

4.11 A headset may be attached to any keyset by unplugging the handset from the handset jack on the base of the keyset, plugging the headset into the handset jack, and entering a feature code to enable the headset. The ON/OFF key, which is used to turn the headset on and off, is lit when placing and receiving calls and unlit when the headset is not in use. The Standard and Executive Keysets are compatible with industry-standard, four-conductor, modular headsets that have dynamic microphones, or carbon-microphone headsets that are connected to the keyset through an externally powered jackset (which makes the headset dynamic-compatible). The GLX-Plus Keyset is compatible with industry-standard, four-conductor, modular headsets that have electret microphones. Refer to page 3-25 for installation instructions.

Optional Handset Amplifiers

4.12 Although all keysets are equipped with hearing aid-compatible (HAC) handsets, hard-of-hearing users may wish to have an adjustable amplifier installed. An amplifier may also be useful when the keyset is located in a noisy areas where users need to increase the receiver volume. The typical handset amplifier is an external device that plugs into the keyset (where the handset is normally connected); the handset is then plugged into the amplifier. Receiver voice volume is controlled by turning a thumbwheel (or similar control) located on the amplifier. Such amplifiers are generally equipped with a transformer that requires a 110VAC outlet. Refer to page 3-25 for installation instructions.

NOTE: Due to its unique volume control circuitry, the GLX-Plus Keyset does not require a handset amplifier.

4.13 Inter-Tel recommends the Walker Universal Amplified Handsets (standard model W6-UNI-K or noise-cancelling model W6-UNI-K-NC). These amplifiers, which are compatible with carbon, dynamic, and electret microphones, are available from: Walker Equipment Corporation, P.O. Box M, Highway 151 South, Ringgold, Georgia 30736, (800) 426-3738 or (404) 935-2600. When ordering, specify the color: ivory, black, or pearl.

Optional Data Device or LRA for Executive and GLX-Plus Keysets

4.14 The Executive Keyset has a four-conductor modular jack that can be used to connect *either* a data device (such as a personal computer equipped with a modem) *or* a loud ringing adapter (LRA) and an external signal-

ing device (such as a loud bell, horn, flashing light, etc.) to the keyset.

4.15 GLX-Plus keysets may be equipped with optional Data Port Modules (part number 828.1094). The module contains a four-conductor, RJ11 modular jack that can be used to connect *either* a data device (such as a personal computer equipped with a modem) *or* a loud ringing adapter (LRA) and an external signaling device (such as a loud bell, horn, flashing light, etc.) to the keyset. The Data Port Module is a source for 20-26mA of loop current. Refer to page 3-27 for instructions on installing the optional Data Port Module.

4.16 Specifications for modem-equipped data device: The data device must have a direct-connection modem. The modem must be externally powered (or capable of operating on 20mA of loop current) and have an RJ11 CO interface. The data device can be used with the keyset to communicate with remote data equipment over voice channels being used for CO or intercom calls. Refer to pages 3-27 and 4-10 for installation and operation instructions.

4.17 Specifications for loud ringing adapter (LRA): An external LRA may be connected to provide a relay for controlling external signaling devices. The LRA is connected to the keyset (or its attached Data Port Module), and the external signaling device is connected to the LRA. Refer to page 3-29 for installation instructions. Each time the keyset rings, the keyset (or Data Port Module) provides 20-26mA of loop current to the LRA. This causes the LRA contacts to close and activates the signaling device. The LRA is not affected by the ring tone or the ringer volume of the keyset.

4.18 The LRA device must meet the following characteristics.

- Relay coil nominal draw of 20mA
- Relay coil resistance of 100-400 ohms
- Minimum voltage of 17VDC
- Maximum voltage of 36VDC
- Contact rating of 120VRMS minimum

4.19 Some types of signalling devices generate a current/voltage rating that could damage the LRA. The following Wheelock products have been found to work properly with the GLX-Plus System.

- Wheelock DCI-24-24 is an adapter that is used with Wheelock signaling devices.
- Wheelock CRT-D-37 is a dry contact relay that is used with other manufacturer's signaling devices.

4.20 The LRA output of the Data Port Module is connected to the dry contact input on the Wheelock unit. Wheelock products can be ordered from a local supply

house, or call Wheelock directly at (201) 222-6880. Installation and operation instructions are included with each device.

Optional GLX-Plus Keypad Battery Back-Up

4.21 Each GLX-Plus Keypad is equipped with its own internal clock. On display keypads, the clock can be set to show the current date and time (see page 4-34 for more information). If the keypad is unplugged or loses power, the date and time display defaults to "00:00 MON JAN 01" and must be reprogrammed.

4.22 In addition, each GLX-Plus Keypad also has VOL UP and VOL DN keys that allow the user to individually control and save speakerphone, handset, and ring tone volume levels. If the keypad is unplugged or loses power, the all saved volume levels return to the default settings.

4.23 To preserve the date and time display and the volume control settings during a power interruption, each

GLX-Plus keypad may be equipped with optional battery back-up using a battery connection kit (828.1239) and a customer-provided 9V battery. The battery, when fresh, should save the date, time, and volume settings for approximately seven hours of accumulated down time. (See page 3-30 for battery installation instructions.)

C. SINGLE-LINE SETS

4.24 Up to two industry-standard, AC-ringing, single-line DTMF sets may be installed on a GLX-Plus System that is equipped with an optional APM.

NOTE: The APM is supported only on KSUs equipped with the current 827.4012 software.

4.25 Single-line set users access some station features simply by lifting the handset and entering a feature code. Other features are accessed using a combination of a hookflash and a feature code. Refer to the FEATURES section of this manual for details.

5. OPTIONAL SYSTEM EQUIPMENT

A. SYSTEM BATTERY BACK-UP

5.1 To provide back-up power in the event of an AC power failure or brownout condition, the GLX-Plus System power supply can have optional battery back-up using a customer-provided uninterruptible power supply (UPS) unit or a standby power supply (SPS) unit.

5.2 The UPS or SPS unit, which is connected between the AC outlet and the KSU's AC power cord, must have the following characteristics:

- Sine wave output
- Transfer time of less than 25 milliseconds (a unit with a slower switching time may result in calls being dropped when back-up power is switched on)
- Output rating of 50 Watts
- Low voltage cutoff circuit of 105VAC (minimum)
- Batteries can be internal or external

NOTE: Even if the power supply unit has the specifications listed above, it cannot be guaranteed that it will work properly with the Inter-Tel GLX-Plus System. Contact Customer Support for a listing of approved UPS/SPS power supplies and installation instructions.

B. REPEATER APPLICATION FOR AMPLIFIED CO LINES

5.3 Under most circumstances, the voice volume levels on outside calls are quite acceptable. However, during conferences involving multiple outside parties, some reduction in voice volume may be noticed because the GLX-Plus System is a passive design system and does not amplify conferencing. To increase the voice volume levels, Inter-Tel recommends the use of one of the following "repeater" products: the Tellabs 7201 2-Wire Switched Gain Repeater or the R-TEC UM1000 L3 Switched Gain Repeater. Both products provide from 0-15 decibels of voice volume gain and allow regulation of the gain in each direction when simultaneous voice transmission occurs. The switching sensitivity on both units is adjustable. For more information, refer to the manufacturer's specifications provided with each product.

NOTE: Installing the repeater product on a CO line will increase the voice volume levels of all calls using that line. For this reason, it may be desirable to install the product on one CO line and then use that line mainly for establishing outside conferences.

5.4 Both products are installed at the MDF between the telephone company RJ14 jacks or RJ21X block and the KSU. When ordering a repeater unit, consult with the supplier for ordering the proper mounting shelf and

power supply for the unit. The table below outlines the connections necessary for proper installation with the GLX-Plus System.

CONNECT	R-TEC PIN	TELLABS PIN
-Battery (-24 to -56VDC)	K	35
Ground	M	17
Telco — Tip	E	51
Telco — Ring	H	33
System — Tip	5	41
System — Ring	7	49

5.5 Additional information on operating and adjusting the repeater unit is included with the product.

C. DOORBOX

5.6 For a doorbox application, Inter-Tel recommends the Valcom V-2901 Universal Door Answering Unit. This unit, along with the Valcom V-1070A Door Plate Speaker, is hooked up to a CO circuit on the GLX-Plus System. When a person presses a button on the door plate speaker, the unit generates ringing on the CO line. By answering the ringing line, a system user can talk with the person at the door. If the door is equipped with an electric strike plate, the system user may allow access by dialing a code or pressing an external button. To call the Valcom doorbox, the system user goes off hook and presses the line key assigned to the unit (or dials the appropriate CO line access code).

5.7 In database programming, make sure that the desired keysets have access to the CO line assigned to the Valcom unit. Also, assign CO line ring-in to the keyset(s) that will be answering calls from the Valcom unit.

5.8 The Valcom door answering unit and talkback speaker can be ordered from a local supply house. Installation and operation instructions are included with the unit.

D. ANSWERING MACHINE OR VOICE MAIL UNIT

5.9 If desired, an optional answering machine or voice mail unit can be connected to an available single-line circuit on the GLX-Plus APM. Depending on the specific capabilities of the unit, calls can easily be placed, transferred, or forwarded to the answering machine or voice mail unit.

5.10 For additional information and for specific voice mail unit recommendations, contact Customer Support.

NOTE: The GLX-Plus System does not have loop current detection capabilities. Therefore, disconnect supervision or any drop in loop current will not cause the GLX-Plus to drop the CO line connection. If an answer-

FIGURE 2-5. STANDARD KEYSSET

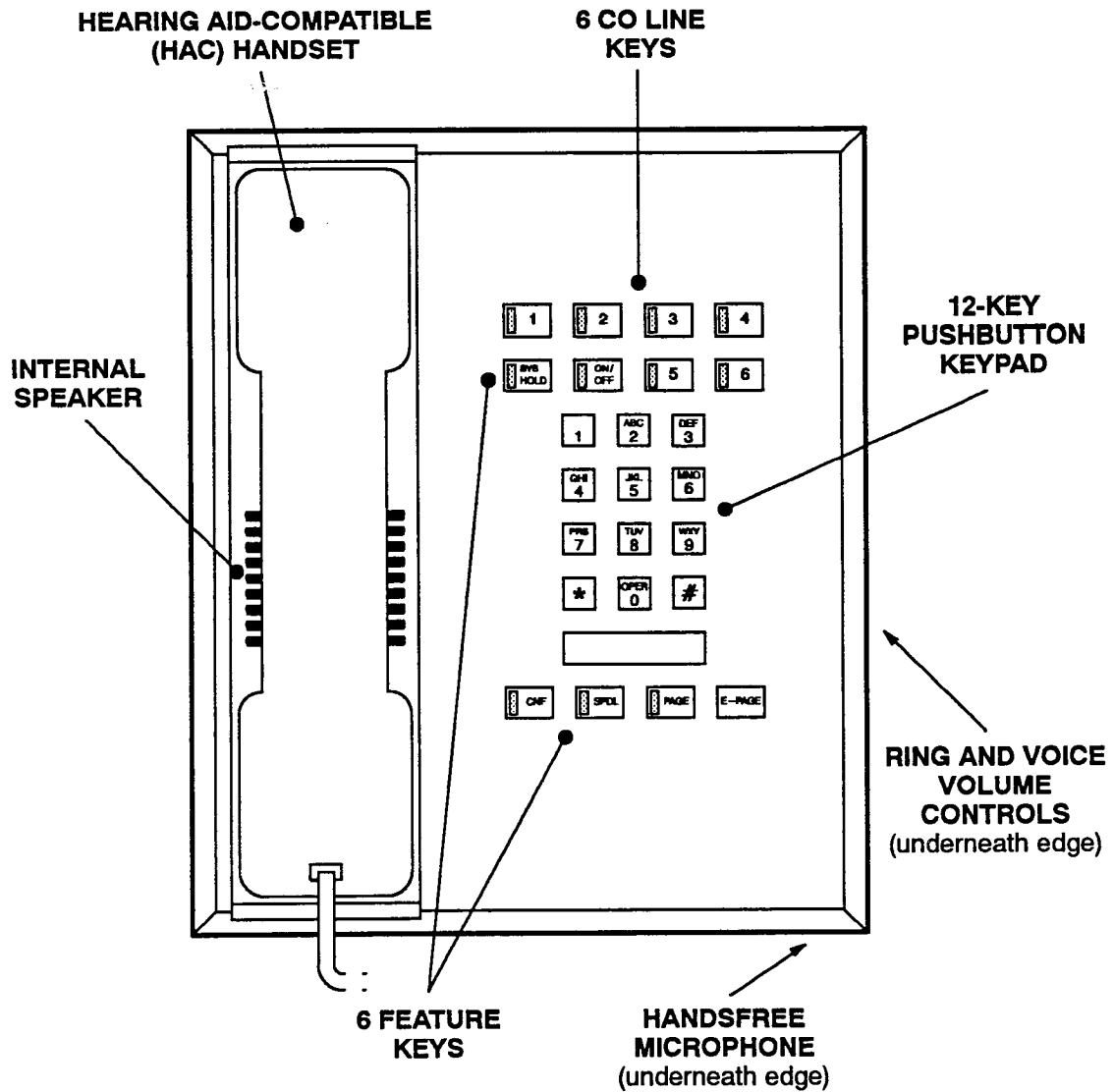

FIGURE 2-6. EXECUTIVE KEYSET

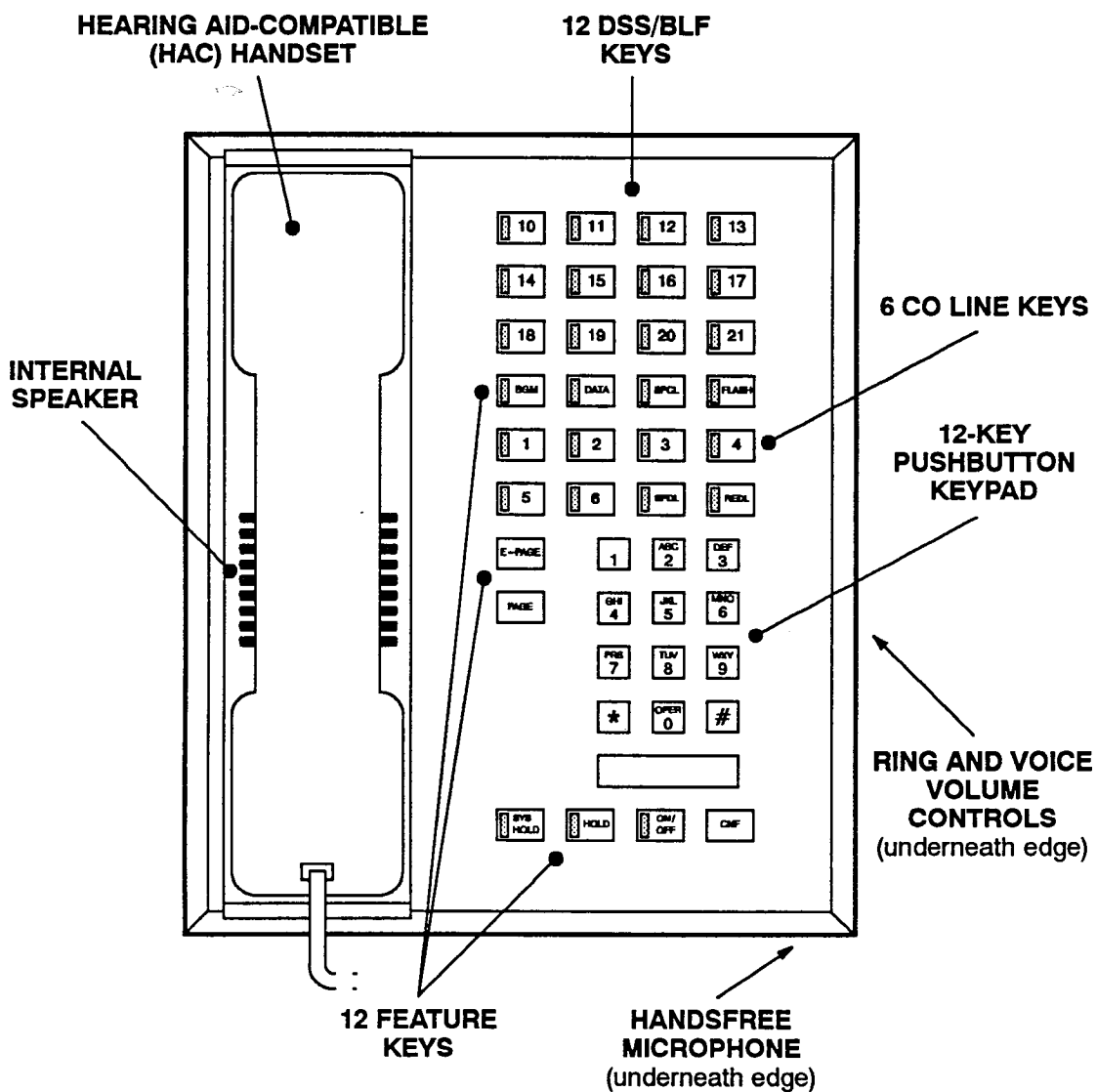
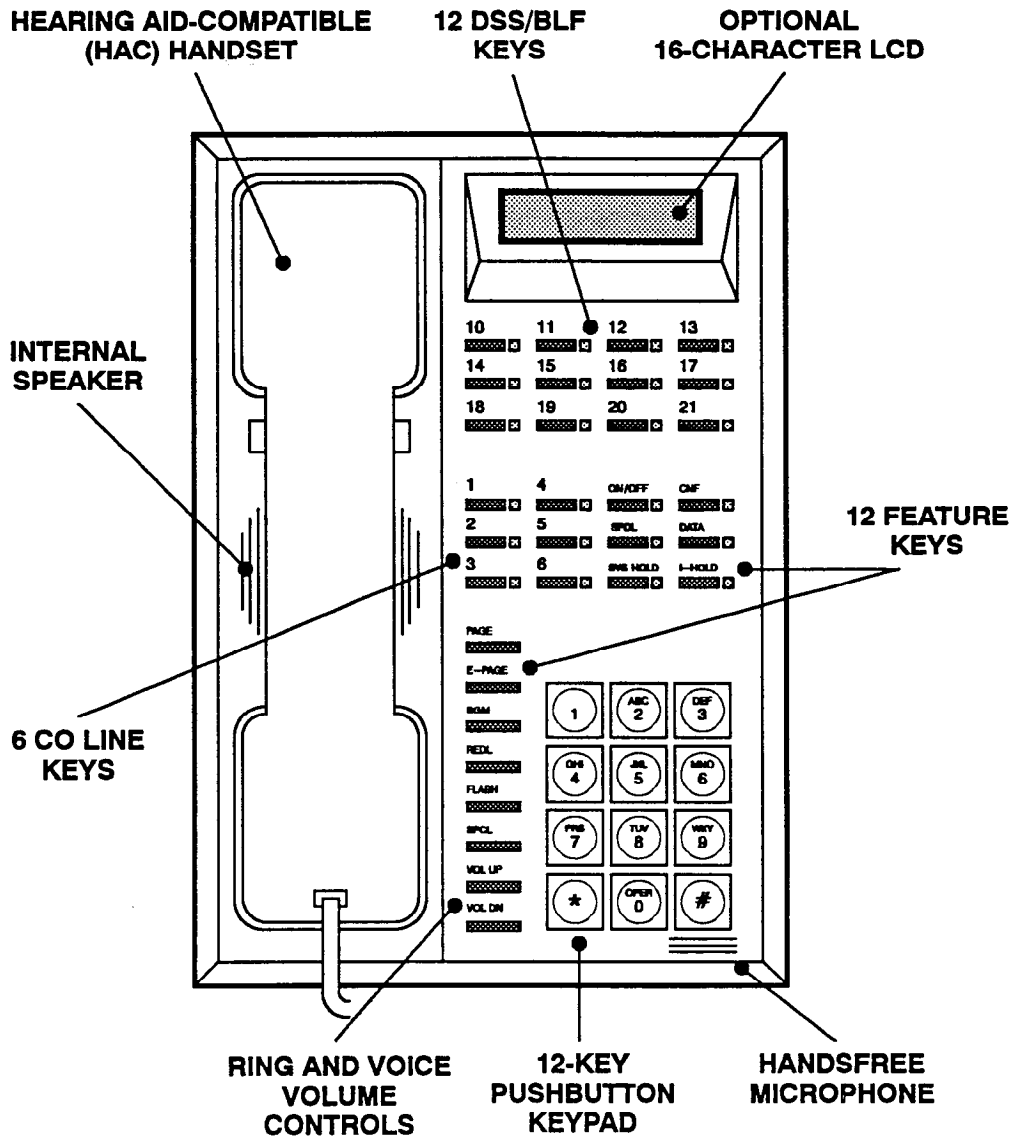

FIGURE 2-7. GLX-PLUS KEYS



INSTALLATION

<i>CONTENTS</i>	<i>PAGE</i>
1. Introduction	3-2
2. System Installation Outline	3-2
3. Pre-Installation Checklist	3-4
A. Establish Suitable Environmental Conditions For The System	3-4
B. Assemble The Necessary Tools And Supplies	3-4
C. Plan Station Locations And Types Of Station Instruments	3-5
D. Assemble The Optional Equipment	3-5
4. Station Cabling And Terminations	3-6
A. Running Cable	3-6
B. Terminating The Cables At Station Locations	3-7
C. Terminating Station Cables At The Main Distribution Frame (MDF)	3-8
D. Station Loop Resistance Test	3-11
5. Terminating CO Lines At The MDF	3-12
A. CO Lines Terminated On RJ14 Jacks Near The MDF	3-12
B. CO Lines Terminated On RJ14 Jacks Away From The MDF	3-12
C. CO Lines Terminated On An RJ21X Block	3-14
6. KSU Installation	3-15
A. Unpack And Inspect The KSU	3-15
B. Install The Expansion PCB In The KSU	3-16
C. Install The Accessory Port Module (APM) In The KSU	3-16
D. Mount The KSU	3-18
E. Complete All Connections For The KSU	3-21
7. Station Installation	3-22
A. Keypad Installation	3-22
B. Single-Line Set Installation	3-31
8. External Paging Equipment Installation	3-31
9. External Music Source Installation	3-31
10. Battery Back-Up Equipment	3-33
11. Post-Installation Checklist	3-33

1. INTRODUCTION

1.1 This section of the manual describes the recommended procedures for installing the GLX-Plus System hardware. Refer to the SPECIFICATIONS section of this manual for hardware descriptions.

2. SYSTEM INSTALLATION OUTLINE

2.1 System installation is performed in the following order. Detailed instructions and figures for each step are located throughout the INSTALLATION section.

- (1) Plan the installation, including the Key Service Unit (KSU) and main distribution frame (MDF) location, station locations, cable runs, and optional equipment. (Refer to the sample system layout shown in Figure 3-1 on the next page.)
- (2) Run station cables to the keysets and single-line sets. Run wiring to any optional equipment, such as the external paging network, external music source, etc.
- (3) Terminate the station cables on modular jack assemblies at the station locations.
- (4) Mount the MDF backboard, assemble the station block on the backboard, and connect the station cables to the station block.
- (5) Perform the station loop resistance test for each station cable.
- (6) If necessary, terminate the CO lines on modular jack assemblies at the MDF.
- (7) If necessary, attach the Expansion PCB or the Accessory Port Module (APM) to the KSU.
- (8) Mount the KSU on the MDF backboard.
- (9) Ground the KSU.
- (10) Connect the KSU to the cables and line cords that run from the MDF.
- (11) Install the station instruments and any optional station equipment, such as headsets, handset amplifiers, and Data Port Modules.
- (12) Install any optional system equipment, such as external music source, external paging network, voice mail, answering machine, facsimile machine, etc.
- (13) Ensure that all equipment is working properly.
- (14) Refer to the PROGRAMMING section of this manual to initialize and program the system.

NOTICE

This *GLX-Plus Installation and Field Maintenance Manual* instructs field technicians on the proper installation practices for the GLX-Plus System. This manual does *not* provide step-by-step instructions for premises wiring practices as dictated by the National Electrical Code, which includes, but is not limited to, cable layouts, cable installation, AC power installation, proper AC grounding, eliminating or preventing external interferences (including, but not limited to, RFI, EMI, lightning, AC power disturbances, static discharge), and other telephony practices standard within the industry. Cable installers, electricians, and field technicians are expected to be properly trained and, if applicable, licensed in their trade practices.

FIGURE 3-1. SAMPLE SYSTEM LAYOUT

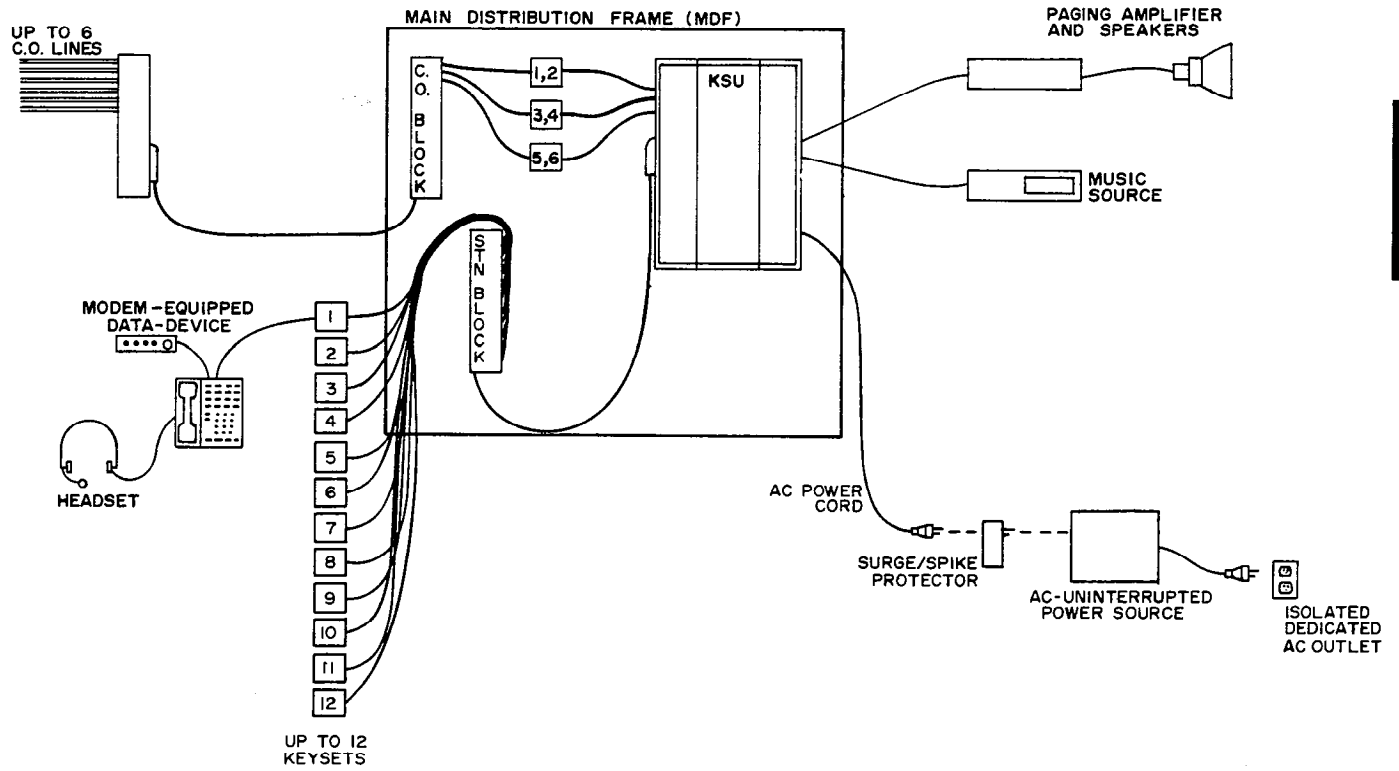

3. PRE-INSTALLATION CHECKLIST

3.1 To make installation easier, use the checklist on the following pages when preparing to install the system. (Hardware specifications are included in the SPECIFICATIONS section.)

A. ESTABLISH SUITABLE ENVIRONMENTAL CONDITIONS FOR THE SYSTEM

- Locate the KSU within 9 feet (3 meters) of an isolated, dedicated, 105–125VAC, 57–63Hz, 15A, single-phase commercial power source.

NOTE: This *must* be an isolated, dedicated AC circuit for proper operation. All three wires (power, neutral, and ground) must be run separately from the outlet to the breaker panel without being bonded to any other wire or circuit. *DO NOT* plug any other equipment into this outlet. To maintain the protection provided by the isolated, dedicated circuit, the length of the AC power cord limits the distance between the power supply and the outlet; *DO NOT* use an extension cord. Also, to protect the system from AC voltage surges, a surge/spike protector is recommended (refer to page 2–5 for specifications).

- Allow room near the KSU for the paging amplifier, battery back-up equipment, and the external music source, if used. To avoid interference, the music source should be placed 5 to 10 feet (1.5 to 3 meters) away from the KSU.
- Make sure there are AC outlets for a music source and a paging amplifier, if they are to be installed. These outlets *MUST NOT* be on the same circuit as the outlet for the KSU.
- Select the KSU location to minimize cable run length. Station instruments connected to the system must not exceed the limits (using 24AWG wire) listed in the table on page 3–11. The ohm values are loop measurements; feet (meter) values are the maximum one-way measurements from the KSU.
- Do not expose the KSU location to direct sunlight, high humidity, heat, dust, or strong magnetic fields (such as those generated by heavy motors and large copy machines).
- The main distribution frame (MDF) requires a 3 × 4-foot (0.9 × 1.2-meter), ¾-inch plywood backboard. This should provide sufficient room for the KSU and power supply, plus all blocks, modular jack assemblies, and peripheral equipment.
- Ample air space should be provided for the KSU since the power supply is convection cooled. *DO*

NOT block the cooling vents located on the top and bottom of the KSU. Never place anything on top of the KSU.

- Locate the equipment in a climate-controlled room with the proper environmental conditions. (See page 2–3 for specific requirements.)
- If keysets are wall mounted, the wall should be able to support twice the weight of the keyset.

From UL 1459, a product safety specification governing telephone equipment:

- Never install telephone wiring during a lightning storm.
- Never install telephone jacks in wet locations unless the jack is specifically designed for wet locations.
- Never touch uninsulated telephone wires or terminals unless the telephone line has been disconnected at the network interface.
- Use caution when installing or modifying telephone lines.

B. ASSEMBLE THE NECESSARY TOOLS AND SUPPLIES

- Industry-standard, two-pair (four-conductor), twisted-pair cable to run from the MDF to keysets, single-line DTMF sets, etc. (For exceptions, see the NOTE under “Running Cable” on page 3–6.)
- Four-conductor modular jack assemblies for keysets, single-line DTMF sets, etc. (For exceptions, see the NOTE under “Running Cable” on page 3–6.)
- A high-impedance digital multimeter to check the power supply and ensure correct wiring of the modular jack assemblies. Multimeter accuracy must be ±0.5% or better.
- Standard terminal block (66M1-50-type) and bridging clips for terminating the station cables at the MDF.
- Industry-standard, 25-pair cable for connecting the MDF station block to the station connections on the KSU.
- 50-pin female amphenol-type connector and a connecting machine.
- A surge/spike protector to protect the system from AC voltage surges.
- Grounding terminal and 10AWG wire for grounding the KSU.

- Standard telephone hand tools and the mounting hardware for the MDF backboard, KSU, terminal block(s), modular jack assemblies, etc.

3.2 Depending on the type of CO termination used by the telephone company and how close it is to the MDF, the following tools and supplies are also needed.

For CO Lines terminated on RJ14 jacks near the MDF:

- For every two CO lines installed, one two-pair mod-to-mod line cord to connect from the RJ14 jack to the corresponding KSU CO jack.

For CO Lines terminated on RJ14 jacks away from the MDF (see Figure 3-5 on page 3-13):

- Two four-conductor modular jack assemblies for every two CO lines installed.
- Two two-pair mod-to-mod line cords for every two CO lines installed.
- Industry-standard, two-pair cable (enough to extend from each RJ14 jack location to the MDF).
- Gas discharge tubes with silicon avalanche suppressors for lightning protection on the CO lines.

For CO Lines terminated on an RJ21X block (see Figure 3-7 on page 3-14):

- One 66M1-50-type terminal connecting block and a supply of bridging clips.
- Industry-standard, 25-pair cable to extend from the RJ21X block to the MDF CO block.
- A 50-pin male amphenol-type connector and connecting machine.
- One four-conductor modular jack assembly for every two CO lines installed.
- One two-pair mod-to-mod line cord for every two CO lines installed.
- Industry-standard, two-pair cable (enough to extend from the CO block to each modular jack assembly on the MDF).
- Gas discharge tubes with silicon avalanche suppressors for lightning protection on the CO lines.

C. PLAN STATION LOCATIONS AND TYPES OF STATION INSTRUMENTS

- Prepare a floor plan for the station locations, using a star (home run) configuration. Include each station's intercom number (10-21). Intercom number 10 is assigned to the system attendant.
- **Keysets:** The GLX-Plus System has the capacity for up to 12 keysets. Refer to page 2-9 in SPECIFICATIONS for a listing of the available keyset models and for more information on maximum station capacities.
- **Single-Line Sets:** Up to two industry-standard, single-line DTMF sets can be installed on the system.

D. ASSEMBLE THE OPTIONAL EQUIPMENT

- Headsets and handset amplifiers for keyset and single-line set stations. (Refer to pages 2-10 and 2-10 for more information.)
- Data Port Modules (Executive and GLX-Plus Keysets only) for hooking up either modem-equipped data terminals or loud ringing adapters and external signaling devices. (Refer to page 2-10 for more information.)
- System battery back-up using an uninterruptable power supply or standby power supply unit. (Refer to page 2-12 for specifications.)
- External music source (the cable that connects to the KSU must be equipped with an RCA-type phono plug).
- External paging speakers and amplifier (the cable that connects to the KSU must be equipped with a 1/8-inch mini-phone plug).
- Doorbox equipment. (Refer to page 2-12 for requirements.)
- Facsimile (FAX) machine. (Refer to page 2-13 for more information.)
- Voice mail equipment or answering machine. (Refer to page 2-12 for more information.)
- Station Message Detail Recording (SMDR) Adapter and output device. (Refer to page 2-13 for more information.)

3411
7/7/93

4. STATION CABLING AND TERMINATIONS

4.1 Floor plans should be developed to aid in proper station cabling in a star (home run) configuration from the KSU. The cables are run from the station locations to the station block at the MDF. Refer to page 2-2 for cabling requirements.

4.2 Both ends of each cable should be labeled with the station's intercom number: 10-21. Intercom numbers 10-19 are for keysets only. Intercom numbers 20-21 can be used for either keysets or single-line devices, depending on whether an Expansion PCB or an Accessory Port Module is installed.

A. RUNNING CABLE

NOTE: It is recommended that two-pair cable and four-conductor modular jacks be used for all station connections. This allows the various types of station instruments to be easily interchanged, if necessary. However, if desired, single-line DTMF sets can be installed using one-pair cable and four-conductor modular jacks.

4.3 From the MDF location, run industry standard, two-pair (four-conductor), twisted-pair cable to keysets and single-lines sets following these guidelines:

- Install proper type cable for the application according to the National Electrical Code and local building codes.

- Avoid cable runs parallel to fluorescent light fixtures or AC lines not in conduit. If these obstacles are unavoidable, run the cables across them at right angles.
- Do not run station cables inside electrical conduit already occupied by AC power cable. (To do so is a violation of the National Electrical Code.)
- Do not run cables near equipment with electric motors or through strong magnetic fields, such as those generated by large copy machines, arc welding equipment, heavy motors, etc.
- Do not run cables outdoors. The GLX-Plus System is designed for indoor wiring only.
- Do not place station cables where they can be stepped on or where they can be rolled over by office furniture.
- If using multi-pair (e.g., 25-pair) cable runs to multiple station locations do not include CO lines, AC-ringing single-line sets, or AC-ringing auxiliary equipment in a cable being used for keysets. Keyset circuits should be included in separate multi-pair cable runs.

NOTE: To avoid possible ringing crosstalk, do not run the station cabling for single-line devices in parallel with the station cabling for keysets.

- Do not exceed the loop limit measurements (using 24AWG wire) for the station cable lengths as outlined in the table on page 3-11. The ohm values are loop measurements; feet (meter) values are the maximum one-way measurements from the KSU.

**B. TERMINATING THE CABLES AT
STATION LOCATIONS**

4.4 Terminate the keyset and single-line set station cables on four-conductor modular jack assemblies at the station locations. (For exceptions to this, refer to the NOTE following section A on the previous page.)

4.5 Do not mount the assemblies on the wall at this

time; they will be wall mounted later when the station instruments are installed. Refer to Figure 3-2 below for a wiring diagram.

CAUTION

If the power and ground pair (W/O, O/W) is reversed, the keyset will not function.

FIGURE 3-2. STATION MODULAR JACK ASSEMBLY WIRING

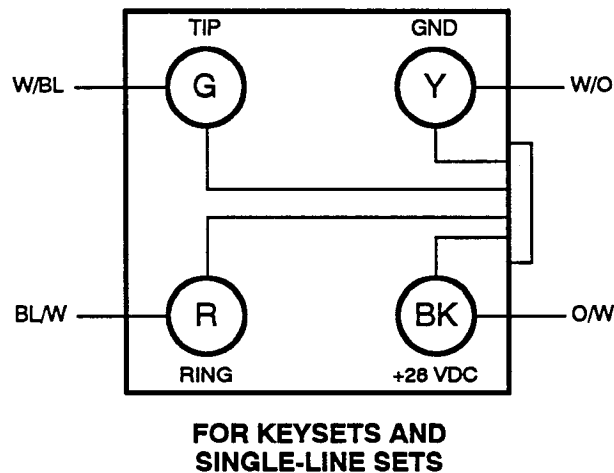

NOTE: Single-line sets use only the tip and ring pair, not the power and ground pair.

C. TERMINATING STATION CABLES AT THE MAIN DISTRIBUTION FRAME (MDF)

4.6 The main distribution frame (MDF) is the point at which the station instruments, CO lines, and auxiliary system equipment are connected to the KSU via terminal blocks and/or modular jack assemblies. It is extremely important that the connections be made carefully and accurately. (Refer to Figure 3-1 on page 3-3 for a sample system layout. For diagrams of possible MDF CO layouts, refer to Figures 3-5 and 3-7 on pages 3-13 and 3-14.)

4.7 Assemble the MDF:

- (1) Mount a 3 × 4-foot (0.9 × 1.2-meter), 3/4-inch plywood backboard at the MDF location.
- (2) Attach a 66M1-50-type terminal block to the plywood backboard.

NOTE: To avoid possible ringing crosstalk, be sure to locate the station terminal block close to the KSU. The 25-pair cable between the block and the KSU should be less than three feet in length.

4.8 After the station cables are run, connect them and the 25-pair cable to the station block on the MDF as follows:

CAUTION

Incorrect wiring of the station block or the station modular jack assembly (i.e., reversing the power pair with the tip and ring pair) can damage the transformer on the Main Control PCB.

- (1) Ensure that both ends of each station cable are labeled with the intercom number of the associated station instrument.
- (2) Terminate each station cable on the *right* side of the station block. Refer to Figure 3-3 on the following page for station cable terminations.
- (3) Using enough 25-pair cable to run from the station block to the left side of the KSU, make the termination cable. Attach a 50-pin female amphenol-type connector to one end of the cable.
- (4) Terminate the other end of the 25-pair cable on the *left* side of the station block. The connector will be attached to the KSU later.
- (5) *DO NOT* attach bridging clips until the loop resistance tests have been performed (as described on page 3-11).

FIGURE 3-3. STATION CABLE TERMINATIONS AT THE MDF

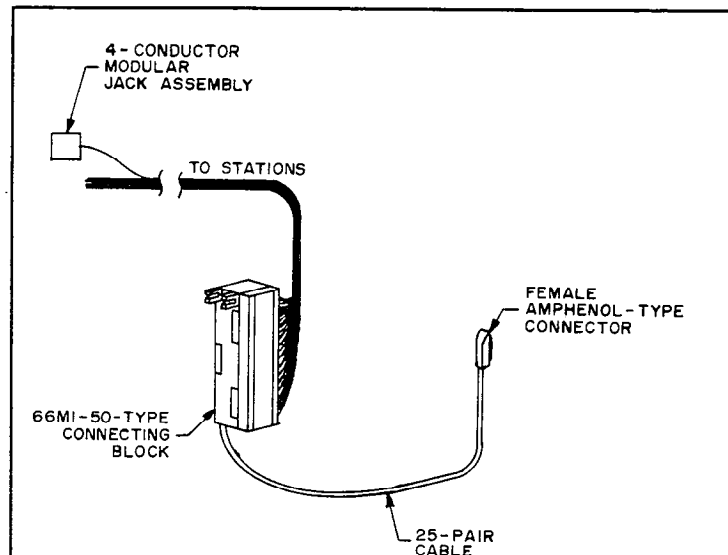
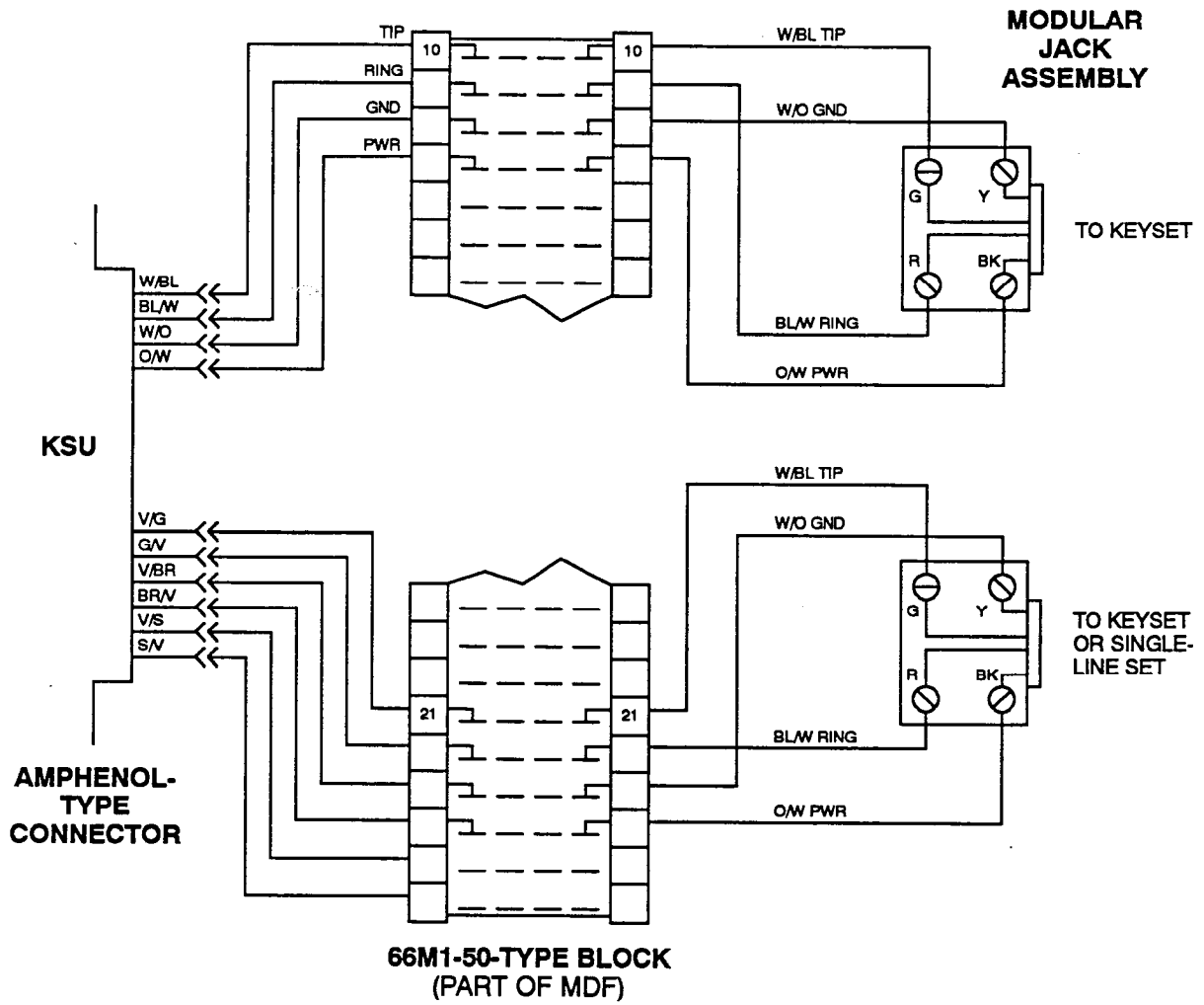

FIGURE 3-4. STATION CABLE TERMINATIONS ON THE STATION BLOCK

AMPHENOL NO.	CABLE PAIR	FUNCTION	STATION NO.	INTERCOM NO.
26	W-BL	TIP	1	10
1	BL-W	RING		
27	W-O	GND		
2	O-W	+28VDC	2	11
28	W-G	TIP		
3	G-W	RING		
29	W-BR	GND	3	12
4	BR-W	+28VDC		
30	W-S	TIP		
5	S-W	RING	4	13
31	R-BL	GND		
6	BL-R	+28VDC		
32	R-O	TIP	5	14
7	O-R	RING		
33	R-G	GND		
8	G-R	+28VDC	6	15
34	R-BR	TIP		
9	BR-R	RING		
35	R-S	GND	7	16
10	S-R	+28VDC		
36	BK-BL	TIP		
11	BL-BK	RING	8	17
37	BK-O	GND		
12	O-BK	+28VDC		
38	BK-G	TIP	9	18
13	G-BK	RING		
39	BK-BR	GND		
14	BR-BK	+28VDC	10	19
40	BK-S	TIP		
15	S-BK	RING		
41	Y-BL	GND	11*	20*
16	BL-Y	+28VDC		
42	Y-O	TIP		
17	O-Y	RING	12*	21*
43	Y-G	GND		
18	G-Y	+28VDC		
44	Y-BR	TIP	N/A	N/A
19	BR-Y	RING		
45	Y-S	GND		
20	S-Y	+28VDC	N/A	N/A
46	V-BL	TIP		
21	BL-V	RING		
47	V-O	GND	N/A	N/A
22	O-V	+28VDC		
48	V-G	TIP		
23	G-V	RING	N/A	N/A
49	V-BR	GND		
24	BR-V	+28VDC		
50	V-S	NOT USED	N/A	N/A
25	S-V	NOT USED	N/A	N/A

* Station numbers 1-10 (intercom numbers 10-19) are reserved for keysets only. Station numbers 11-12 (intercom numbers 20-21) can be used for either keysets or AC-ringing single-line devices, depending on whether an Expansion PCB or an Accessory Port Module is installed.

D. STATION LOOP RESISTANCE TEST

NOTE: If performing the loop resistance test after the system is installed, unplug the keyset from the jack assembly. Then either unplug the 25-pair station cable from the KSU or remove the bridging clips for the desired keyset(s) from the station block.

4.9 Perform the loop resistance test for each station cable individually.

- (1) Ensure that bridging clips have not been installed on the station blocks and that the station instrument is not connected to the modular jack assembly.
- (2) Place a short across the RED and GREEN wires on the modular jack assembly.

- (3) At the MDF, measure the resistance across the WHITE/BLUE and BLUE/WHITE wires on the *right* (station) side of the station block. The reading should not exceed the limits (for 24AWG wire) listed in the table below (ohm values are the loop measurements; feet/meter values are the maximum one-way measurements from the KSU).

NOTE: Excessive and/or improperly made connections increase the resistance of a cable, which reduces the allowable cable run length.

- (4) Remove the short after the test is complete.
- (5) Repeat this test for each station cable.
- (6) Install bridging clips on the station blocks to complete the cable connections.

TYPE OF INSTRUMENT	LOOP LIMITS
Executive Keyset	40 ohms/800 ft. (243 m.)
Standard Keyset	40 ohms/800 ft. (243 m.)
GLX-Plus Keyset (standard or display)	60 ohms/1165 ft. (355 m.)
GLX-Plus Keyset with Data Port Module	10 ohms/195 ft. (59 m.)
Industry-Standard, Single-Line DTMF Sets (AC)	75 ohms/1460 ft. (445 m.)

* Note that if shielded cable is used for any type of keyset installation, the actual loop limit *may* be reduced by as much as 20% because the foil wrapped around the wires in the cable acts as a capacitor.

5. TERMINATING CO LINES AT THE MDF

5.1 The installation procedure used to terminate CO lines at the MDF is dependent on the type of termination used by the telephone company and how close it is to the MDF. The CO lines may be terminated on RJ14 (C or W) jacks or on an RJ21X block.

5.2 Follow one of the three CO termination methods (A, B, or C) outlined on the following pages.

IMPORTANT NOTES:

- The first CO jack on the KSU connects lines 1 and 2, the second connects lines 3 and 4, and the third connects lines 5 and 6. Lines must be connected in that sequence. For example, if three lines are installed, lines 1 and 2 would terminate on the first jack, and line 3 would terminate on the second jack.
- For additional lightning protection, install gas discharge tubes with silicon avalanche suppressors to ground (grounding rod or copper, cold water pipe) on each CO line. This must be done external to the system. Each gas discharge tube is installed directly between the telephone company termination and the system's CO modular jack assemblies located next to the KSU. This protection should give energy absorption and filter low-level surge potentials on the CO lines. If CO termination method A (direct KSU connection) is used, gas discharge tubes cannot be installed; use method B instead. Also, in areas with frequent occurrences of lightning, it is recommended that the cable between the telephone company RJ-type blocks and the gas discharge tubes be at least 75 feet long (the cable may be coiled up if desired).

A. CO LINES TERMINATED ON RJ14 JACKS NEAR THE MDF

5.3 Before using this procedure, read the *IMPORTANT NOTES* following paragraph 5.2. Plug one end of

a two-pair mod-to-mod line cord into each telephone company RJ14 jack. The other end of each line cord will *later* be plugged into the corresponding CO jack on the KSU.

B. CO LINES TERMINATED ON RJ14 JACKS AWAY FROM THE MDF

5.4 Before using this procedure, read the *IMPORTANT NOTES* following paragraph 5.2. Also, refer to Figure 3-5 on the next page for a diagram of the complete layout.

- (1) Mount one four-conductor modular jack assembly next to each telephone company RJ14 jack.
- (2) For each modular jack assembly mounted in step 1, also mount a corresponding four-conductor modular jack assembly on the MDF backboard next to the KSU location.
- (3) To connect the modular jack assemblies mounted in steps 1 and 2:
 - a. Run two-pair cable between the corresponding modular jack assemblies.
 - b. Wire each end of the two-pair cables onto their respective modular jack assemblies. Refer to Figure 3-6 on the next page for a diagram of the wiring.
- (4) Plug one end of a two-pair mod-to-mod line cord into each RJ14 jack and plug the other end into the corresponding modular jack assembly beside it.
- (5) At the MDF backboard, plug one end of a two-pair mod-to-mod line cord into each modular jack assembly. The other end will *later* be plugged into the corresponding CO jack on the KSU.

FIGURE 3-5. CO LINE TERMINATIONS FROM RJ14 JACKS

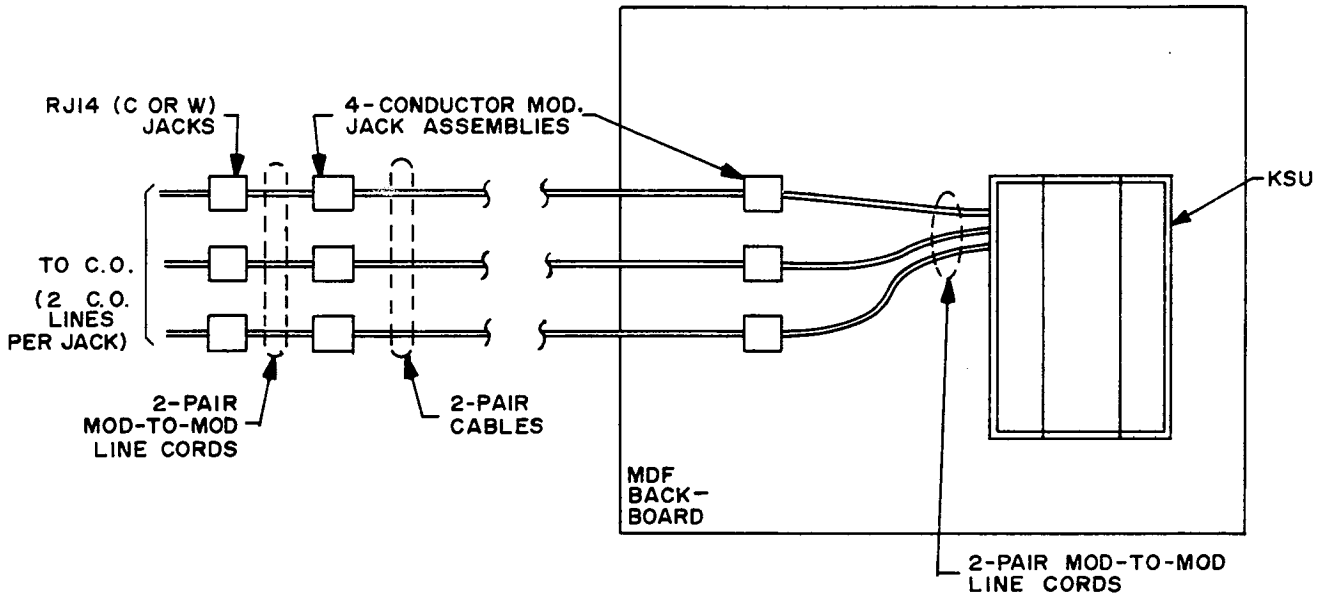
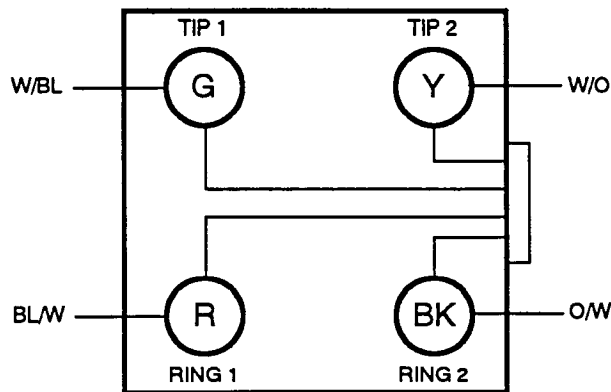

FIGURE 3-6. MODULAR JACK ASSEMBLY WIRING FOR CO LINES



C. CO LINES TERMINATED ON AN RJ21X BLOCK

5.5 Before using this procedure, read the *IMPORTANT NOTES* following paragraph 5.2 on page 3-12. Also, refer to Figure 3-7 below for a diagram of the complete layout.

- (1) Mount a CO (66M1-50-type) connecting block on the MDF backboard.
- (2) For every two CO lines, mount a four-conductor modular jack assembly on the MDF backboard near the KSU. The modular jack assemblies should be positioned between the CO block (mounted in step 1) and the KSU.
- (3) For each modular jack assembly (mounted in step 2), connect a two-pair cable (or cross-connect cable) from it to the CO block as follows:
 - a. Terminate one end of a two-pair cable on each modular jack assembly. Refer to Figure 3-6 on the previous page.
 - b. Terminate the other end of the two-pair cable on the *right* side of the CO block, with CO line 1 tip and ring first, then CO line 2 tip and ring, and so on.
- (4) Plug one end of a two-pair mod-to-mod line cord into each modular jack assembly (mounted in step 2). The other end will *later* be plugged into the corresponding CO jack on the KSU.
- (5) To interface between the CO block and the RJ21X block:
 - a. Run a 25-pair cable between the CO block and the RJ21X block.
 - b. Terminate the MDF end of the 25-pair cable on the *left* side of the CO block. Install bridging clips to complete the connections.
 - c. On the RJ21X end of the 25-pair cable, attach a 50-pin male amphenol-type connector.
 - d. Plug the male connector into the female connector on the RJ21X block.

FIGURE 3-7. CO LINE TERMINATIONS FROM AN RJ21X BLOCK

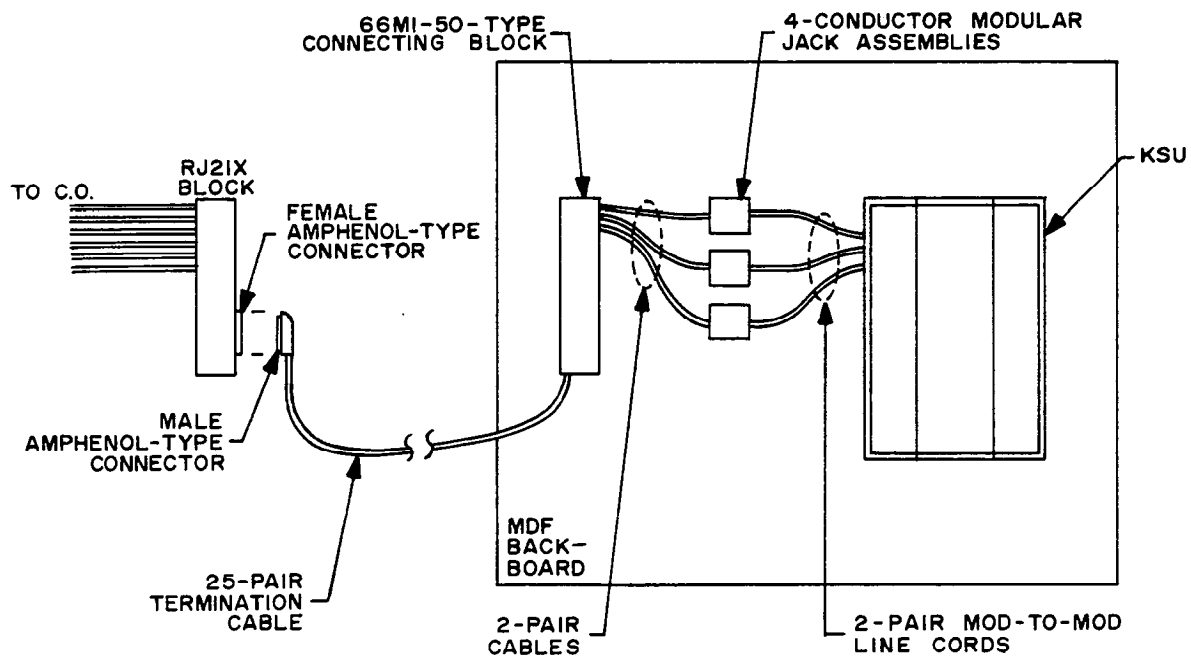

6. KSU INSTALLATION

A. UNPACK AND INSPECT THE KSU

- (1) Unpack the KSU and lay it on a flat surface with the cover facing up. Open it by removing the four retaining screws and lifting off the cover.

CAUTION

The PCBs contain static-sensitive components. Lift them only by the edges and carefully handle the components while inspecting them in the next step.

- (2) Inspect the fuses for the correct voltage and current rating. The AC fuse (2A, 250V, slow-blow) is accessible from the outer, right side of the KSU. The three station fuses (1A, 250V, fast-acting) are mounted on the lower right corner of the Main Control PCB. Ensure that the ROM integrated circuit is properly seated in socket UB4. (See Figure 3-8 below.)

NOTE: If the Main Control PCB has a jumper strap J20 located above the integrated circuit

UC1, make sure the strap is in the GH position. If the jumper strap is placed in the HI position, the system may function erratically.

- (3) If the KSU or any of its components are damaged, contact your supplier immediately.
- (4) You **MUST** activate the lithium battery by removing the red piece of paper located between it and the battery clip. Otherwise, the database memory will not be protected during a power outage.
- (5) If you are installing the Expansion PCB or Accessory Port Module, proceed to section B or C. Otherwise, replace the KSU cover and secure it with the four screws; then proceed to section D.

CAUTION

If the KSU is taken out of service, be sure to insert a piece of paper between the battery and the clip to break the contact. Otherwise, the battery will continue to discharge and will eventually have to be replaced.

FIGURE 3-8. KSU COMPONENT LOCATIONS

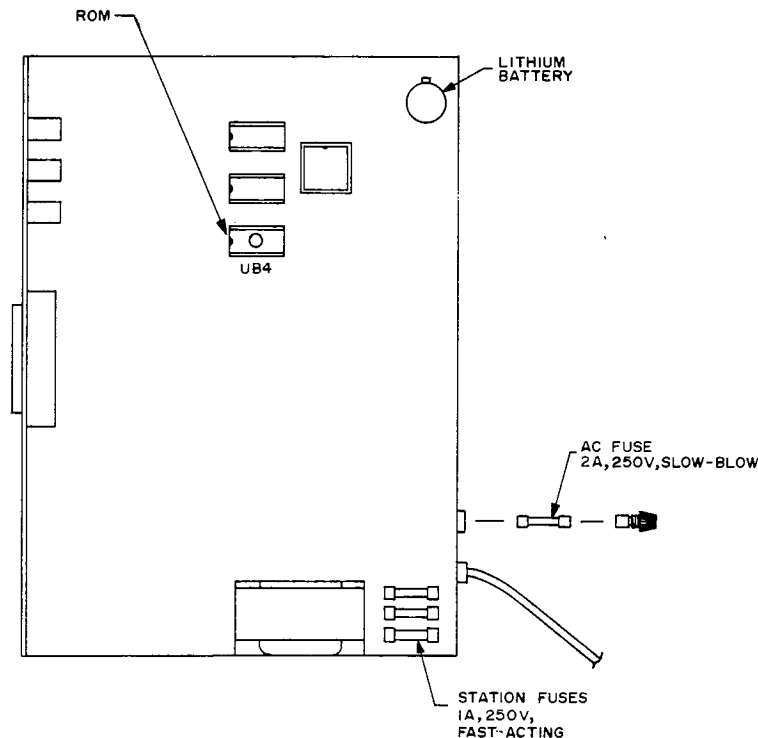

B. INSTALL THE EXPANSION PCB IN THE KSU

NOTE: Only one Expansion PCB *or* only one APM can be added to the KSU. It is not possible to install both boards.

6.1 The Main Control PCB has circuitry for 3 CO lines and 8 keysets. The Expansion PCB adds circuitry for 3 CO lines and 4 keysets, completing the 6 × 12 configuration.

NOTE: If you are adding the Expansion PCB after the system has been installed, turn off the KSU AC power switch (PWR), unplug the KSU AC power cord, and unplug the 25-pair station cable and CO line cords from the KSU. Remove the KSU from the wall and open it according to the instructions in section A.

- (1) Remove the six retaining screws (eight in some KSUs) holding the Main Control PCB to the KSU housing. Handle PCBs by the edges only; they contain static-sensitive components.
- (2) Carefully lift the PCB, turn it over, and hold it by the edges. Take care not to dislodge any of the wires that connect the components to the switches or connectors.
- (3) With the solder sides of the two PCBs facing each other, carefully insert the Expansion PCB's seven 8-pin connectors and the seven stand-offs into the corresponding sockets and holes on the Main Control PCB as shown in Figure 3-9 on the next page.

NOTE: Older Expansion PCBs and Main Control PCBs have only five stand-offs and five insertion holes. To install a new Expansion PCB on an old Main Control Board, first remove the two extra stand-offs.

- (4) To ensure that the Expansion PCB is properly seated, press firmly on the back of each connector and stand-off.
- (5) Carefully turn the Main Control PCB over and return it to its original position in the KSU housing. Replace the six (or eight) screws.
- (6) Replace the KSU cover and the retaining screws.

C. INSTALL THE ACCESSORY PORT MODULE (APM) IN THE KSU

NOTE: The APM is supported only on KSUs equipped with the current 827.4012 software. Also, only one Expansion PCB *or* only one APM can be added to the KSU. It is not possible to install both boards.

6.2 The Main Control PCB has circuitry for 3 CO lines and 8 keysets. The APM adds circuitry for 3 CO lines, 2 keysets, and 2 single-line devices, completing the 6 × 12 configuration.

NOTE: If you are adding the APM after the system has been installed, turn off the KSU AC power switch (PWR), unplug the KSU AC power cord, and unplug the 25-pair station cable and CO line cords from the KSU. Remove the KSU from the wall and open it according to the instructions in section A.

- (1) Remove the six retaining screws (eight in some KSUs) holding the Main Control PCB to the KSU housing. Handle PCBs by the edges only; they contain static-sensitive components.
- (2) Carefully lift the PCB, turn it over, and hold it by the edges. Take care not to dislodge any of the wires that connect the components to the switches or connectors.
- (3) With the solder sides of the two PCBs facing each other, carefully insert the APM's seven 8-pin connectors and the four stand-offs into the corresponding sockets and holes on the Main Control PCB as shown in Figure 3-10 on the next page.
- (4) To ensure that the APM is properly seated, press firmly on the back of each connector and stand-off.
- (5) Carefully turn the Main Control PCB over and return it to its original position in the KSU housing. Replace the six (or eight) screws.
- (6) Replace the KSU cover and the retaining screws.

FIGURE 3-9. INSTALL THE EXPANSION PCB

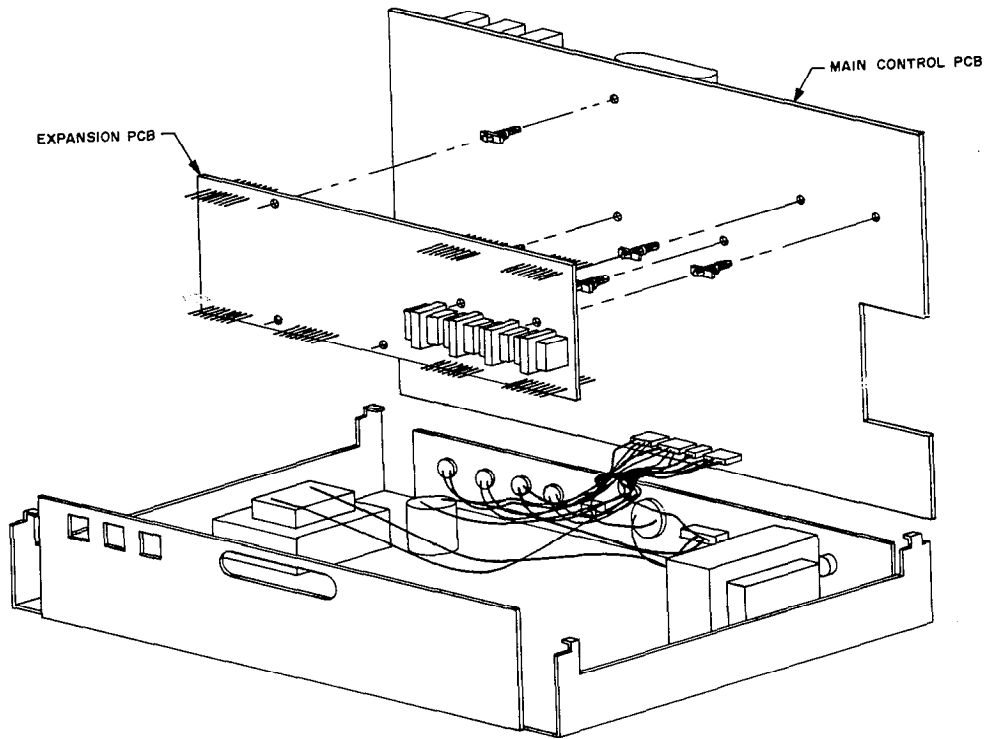
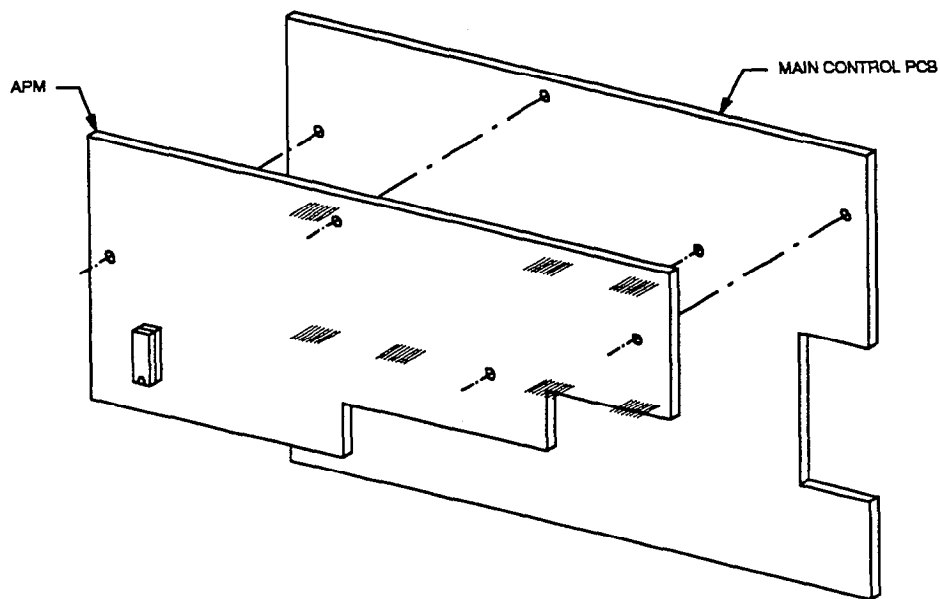

FIGURE 3-10. INSTALL THE APM



D. MOUNT THE KSU

- (1) Refer to Figure 3-11 below. On a large sheet of paper, trace the outline of the back of the KSU and the two mounting screw holes.
- (2) Transfer the mounting hole markings to the MDF backboard where the KSU will be positioned.
- (3) Drive a #8 pan-head screw into the center of each marking, allowing the head of the screw to protrude $\frac{1}{4}$ - to $\frac{1}{2}$ -inch (0.6 to 1.2 centimeters).
- (4) Hang the KSU on the screws. Adjust the screws if necessary to ensure that the KSU is securely mounted.
- (5) *DO NOT* plug in the AC power cord at this time.

FIGURE 3-11. WALL MOUNT THE KSU

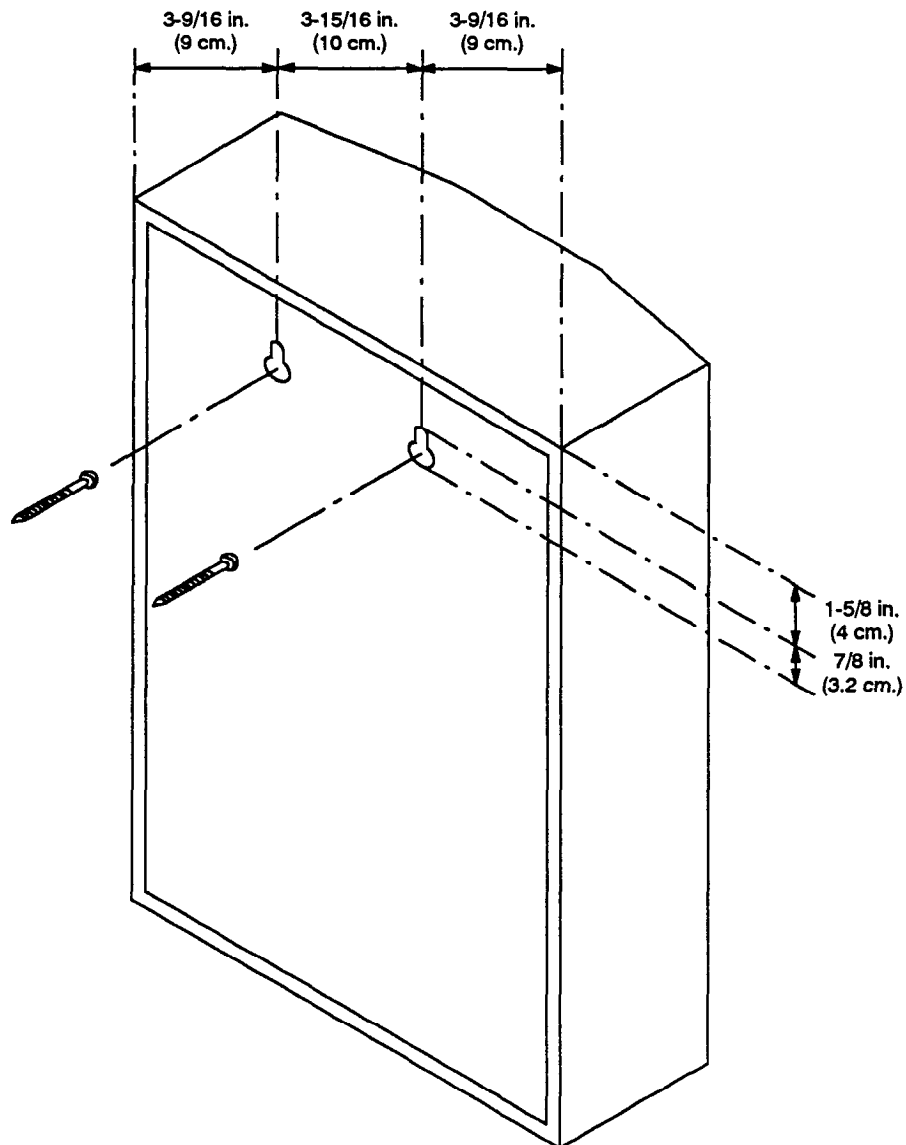

Grounding Requirements

6.3 The KSU must be properly grounded to an earth ground point. A copper, cold water pipe is usually a good ground point

NOTE: According to UL 1459, "an insulated grounding conductor that is not smaller in size and equivalent in insulation material and thickness to the grounded and ungrounded branch-circuit supply conductors, except that it is green with or without one or more yellow stripes, is to be installed as part of the circuit that supplies the product or system." Also, "the attachment-plug receptacles in the vicinity of the product or system are all to be of a grounding type, and the grounding conductors serving these receptacles are to be connected to earth ground at the service equipment."

6.4 The grounding wire should be 10AWG or larger and should not exceed 25 feet (7.5 meters) to help provide RFI/EMI protection, or should not exceed 10 feet (3 meters) to help provide both RFI/EMI and lightning protection.

6.5 To ground the system (see Figure 3-12 below):

- (1) Ensure that the system's AC power cable is not plugged into the AC outlet.
- (2) Mount a grounding terminal on the MDF back-board and connect it to:

- a. An earth ground.
- b. The ground lug on the bottom of the KSU.
- c. Battery compartments, if used.
- d. CO line gas discharge tubes, if used.

6.6 If AC power-related problems appear on the system while in operation, one of the following two methods can be used to test the ground.

- Use a digital multimeter to measure the difference of potential between the KSU ground point and the power neutral, and between the KSU ground point and the third wire ground. If the voltage measurement exceeds 0.5V, noise may develop on the system. If this occurs, call an electrician.
- Use a Megger to test the ground point. (A Megger should be available through the local power company.) The reading should be 5 ohms or less.
- Unplug the AC power cord from the outlet and insert a ground isolation plug into the outlet. Plug the AC power cord into the ground isolation plug. If the problem ceases, call an electrician. When finished, remove the ground isolation plug to restore ground protection.

FIGURE 3-12. KSU GROUNDING

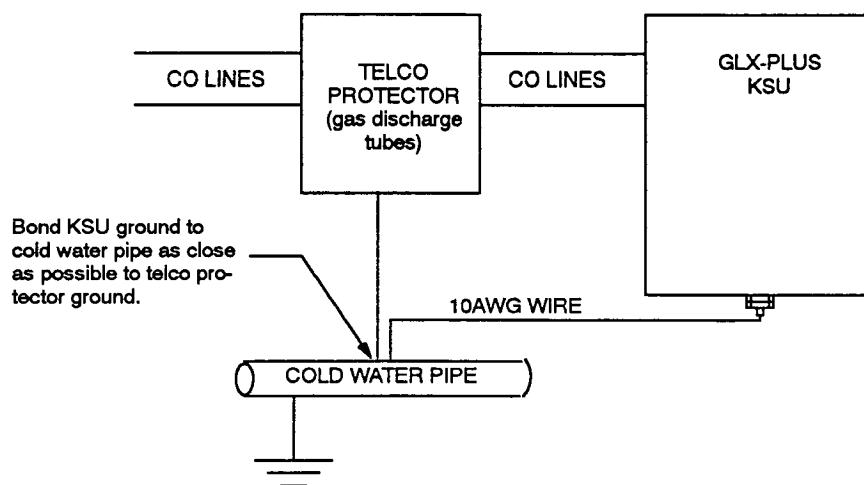

6.7 If the KSU and telco protector are separated by more than 30 feet or if the telco protector ground is inaccessible, additional protection for the C.O. line pairs is recommended. Use a Cook gas protector (part number 502A1-2-LCGX for 2-line, 502A1-4-LCGX for 4-line, 502A1-6-LCGX for 6-line) or equivalent and connect a 10AWG wire between the KSU grounding lug

and the Cook protector's grounding lug as shown below. Then connect a wire (10AWG or larger as determined by the length) between the protector and an approved ground (such as grounded building steel, cold water pipe, concrete encased ground, or a ground ring). The resistance on this wire must be .03 ohms or less.

FIGURE 3-13. KSU GROUNDING

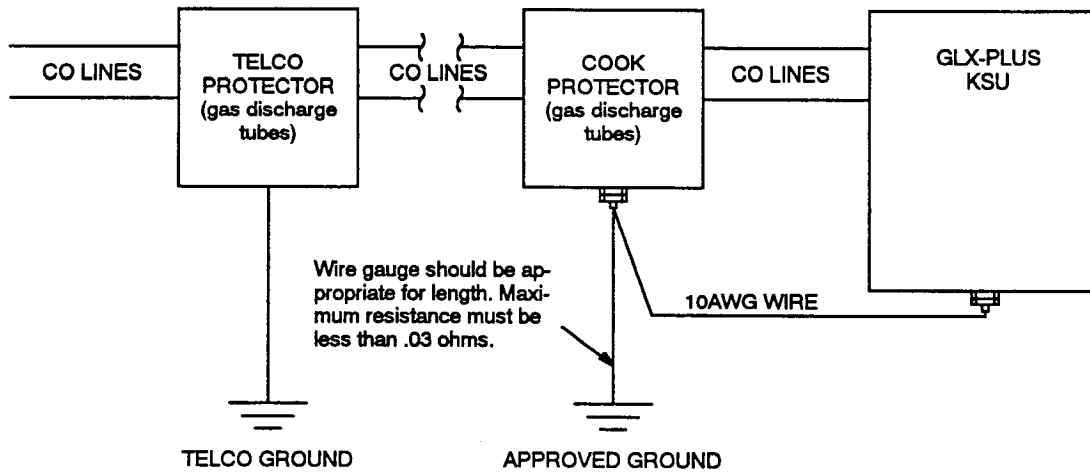

E. COMPLETE ALL CONNECTIONS FOR THE KSU

- (1) To complete the station connections (from the station connecting block to the KSU), attach the station female amphenol-type connector to the male connector on the left side of the KSU.
- (2) To complete the CO line connections (from the CO modular jacks mounted next to the KSU), plug each mod-to-mod CO line cord into the corresponding CO jack on the KSU. The first jack connects lines 1 and 2, the second jack connects lines 3 and 4, and the third jack connects lines 5 and 6.
- (3) Plug the recommended surge/spike protector into the designated AC outlet. Then plug the KSU AC power cord into the protector. (Specifications for the protector are on page 2-5.)
- (4) Turn the AC power switch (PWR) to the ON position.

FIGURE 3-14. COMPLETE THE KSU CONNECTIONS

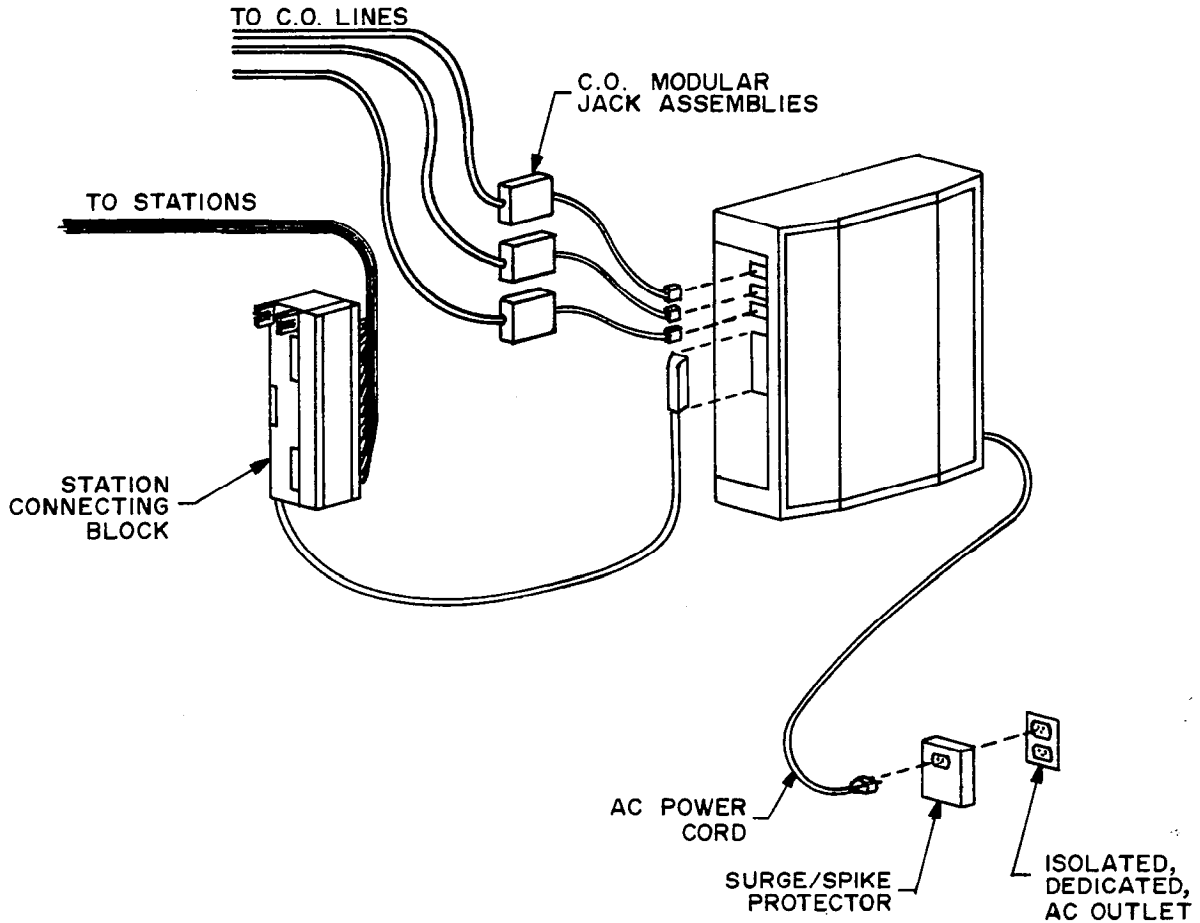

7. STATION INSTALLATION

A. KEYSSET INSTALLATION

7.1 Before installing keysets, unpack each one and check for damage. If items are damaged or missing, contact your supplier. Each keyset should have the following:

- Baseplate
- Extra blank key designation tabs
- One six-foot, three-pair line cord
- One handset
- One four-conductor coiled handset cord
- Slide-out directory card

NOTE: The GLX-Plus Keyset is supported only on KSUs equipped with the current 827.4012 software. Also, GLX-Plus Keysets and handsets have been designed using "electret" microphone circuitry, rather than the "dynamic" microphone circuitry used on Standard and Executive Keysets. Both types of keysets can be used together on the GLX-Plus System. However, if a dynamic handset is attached to an electret keyset, the handset transmit levels will be noticeably lower. If an electret handset is attached to a dynamic keyset, the handset will not transmit.

Optional Liquid Crystal Display (LCD)

7.2 GLX-Plus Keysets are available in both display and non-display models. Non-display GLX-Plus Keysets can be converted to display keysets by installing an LCD Kit (part no. 828.1188) as outlined below.

- (1) Unpack the LCD kit. There should be a clear plastic display window, an LCD unit, a ribbon cable, and two small Phillips-head screws.
- (2) Remove the keyset baseplate to expose the control board that has the LCD connector. (Refer to Figure 3-15 on the next page.)
- (3) Remove the line cord, handset cord, and speaker wires from their connectors on the control board.
- (4) On the back of the keyset, remove the two screws that secure the faceplate assembly to the keyset housing.
- (5) From the front of the keyset, release the tabs that secure the top edge of the faceplate assembly to the keyset housing.

- (6) Starting with the right side, carefully lift the entire faceplate assembly away from the keyset housing.

NOTE: On some keysets, there is a small tab protruding from the front, lower-left corner of the faceplate assembly into the keyset housing. Be careful not to break this tab when removing the faceplate assembly.

- (7) Remove the cover from the display opening in the top of the faceplate assembly by releasing the tabs from the inside and pushing the cover out.
- (8) From the inside of the faceplate assembly, insert one of the top corners of the clear plastic window into the side of the display opening.

NOTE: The small lips on the end of the window should face to the inside of the faceplate assembly. Also, the window is beveled on the top and the bottom so that it will fit flush in only one direction.

- (9) While slightly bending the window, insert the other top corner into the other side of the display opening, and slide the window up until it snaps into place.
- (10) Remove the covering from the LCD unit and install as follows:
 - a. Insert one end of the ribbon cable into the black connector on the LCD unit. Ensure that the metal strips on the ribbon cable make contact with the metal tabs in the black connector.
 - b. With the LCD unit facing up, insert the other end of the ribbon cable into the black connector on the control board (see Figure 3-15).
 - c. Turn the LCD unit over and position it on the plastic window so that the screw holes in the LCD unit align with the screw holes in the faceplate assembly. Install the two Phillips-head screws to hold the LCD unit in place.
- (11) Carefully replace the entire faceplate assembly back in the keyset housing and replace the screws that hold it in place.
- (12) Reconnect the line cord, handset cord, and speaker wires to their connectors on the control board.
- (13) Replace the keyset baseplate.

FIGURE 3-15. GLX-PLUS KEYSSET LCD INSTALLATION

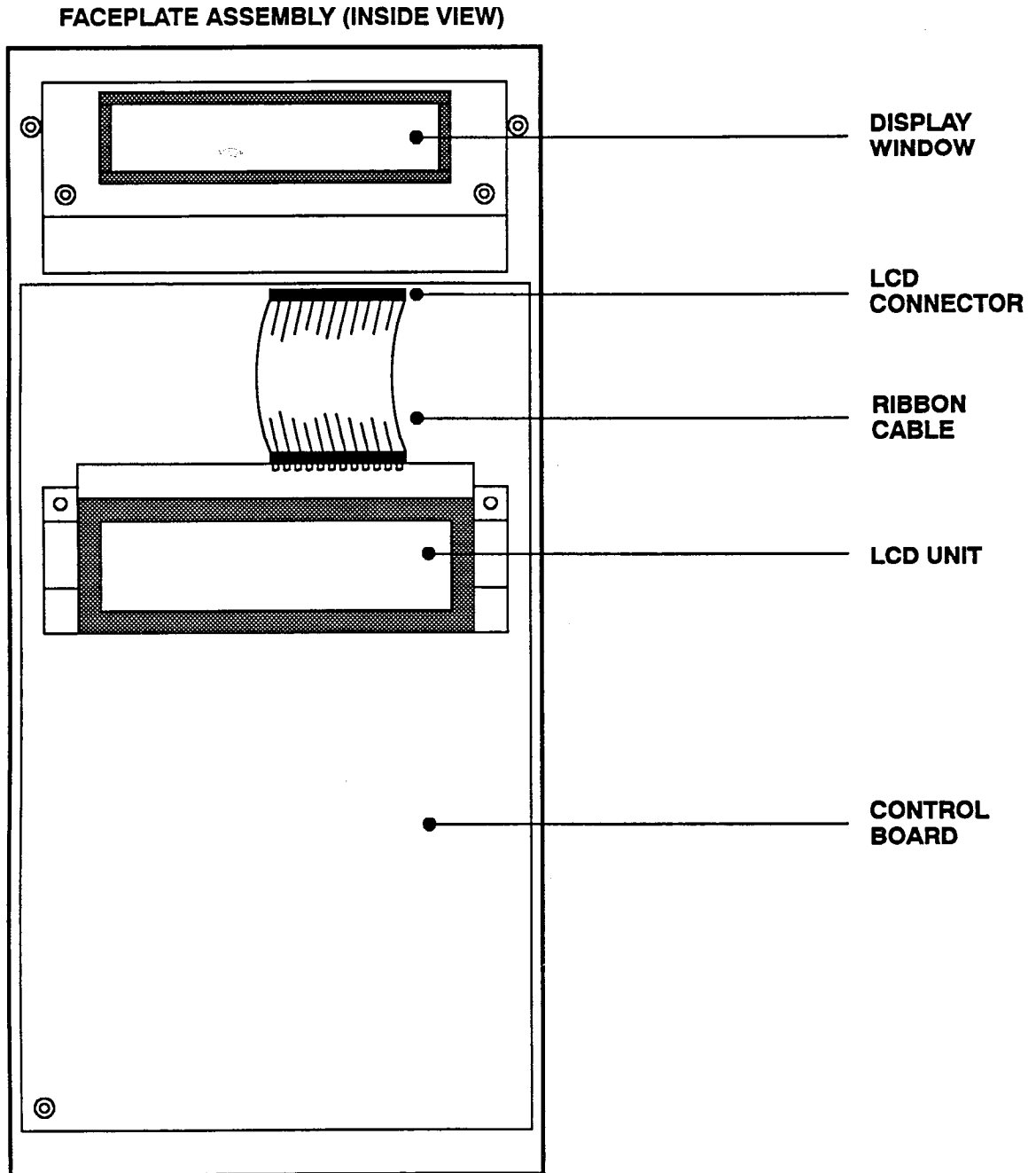

Keyset Installation

7.3 Ensure that the station loop resistance test has been performed before installing the keysets.

7.4 Install all keysets as follows:

- (1) Before mounting the modular jack assembly and connecting the keyset, measure the voltage on the BLACK (+28) terminal of the modular jack assembly with respect to the YELLOW (GND) terminal. (The "common" probe of the voltmeter is placed on the YELLOW terminal.) It must measure +28VDC (± 6.0 VDC). If -28VDC is measured, check the cabling for a reversed pair.
- (2) Check that there is no voltage across the other pair (on the GREEN and RED terminals). If there is voltage, trace the wires back to the KSU and correct the problem.

CAUTION

Incorrect voltage polarity will result in an inoperative keyset.

- (3) After testing all modular jack assemblies, turn the KSU AC power switch (PWR) to the OFF position to avoid shorting components while mounting the modular jack assemblies in the next step.
- (4) Mount the modular jack assembly on the wall.
- (5) Plug one end of the coiled handset cord into the jack on the left side of the keyset. Plug the other end into the handset. Place the handset on hook. (On GLX-Plus Keysets, you will first need to remove the baseplate to expose the control board.)
- (6) Plug one end of the keyset line cord into the modular jack assembly. Plug the other end into the keyset jack labeled KSU.
- (7) After all keysets are installed, turn the KSU AC power switch (PWR) to the ON position.
- (8) *If installing a GLX-Plus Keyset, perform the self-test:*
 - a. While pressing the asterisk (*) and pound (#) keys, unplug and replace the keyset line cord.
 - b. Release the keys. The keyset rings momentarily. (Display keysets show a dark display — all pixels lit.)

- c. Lift and replace the handset. The keyset rings momentarily. (Display keysets show a blank display — no pixels lit.)
- d. Lift and replace the handset. The keyset rings momentarily and all LED-equipped keys light. (Display keysets show LED MATRIX TEST.) If any of the LEDs do not light, return the keyset for repair.
- e. Lift and replace the handset. The keyset rings momentarily and all of the LEDs go out. (Display keysets show KEY MATRIX TEST.)
- f. One at a time, press each of the keys on the keyset in any order. A progress tone (or a DTMF tone for keypad keys) is heard if the key is functioning properly. (Keys with LEDs do *not* light during this test.) If the signals are not heard, the key is faulty. Return the keyset for repair if any key is faulty.
- g. Lift and replace the handset. The audio integrated module tones are broadcast over the speakerphone speaker. (Display keysets show AIM TONES TEST.)
- h. Lift and replace the handset. Audio integrated module tones of various volume levels, from softest to loudest, are broadcast over the speakerphone speaker. (Display keysets show TONE VOLUME TEST.)
- i. Lift and replace the handset. Tones of various volume levels, from softest to loudest, are broadcast over the speakerphone speaker. (Display keysets show SPKR VOLUME TEST.)
- j. Lift the handset, then press and release the hookswitch. Tones of various volume levels, from softest to loudest, are broadcast over the handset receiver. (Display keysets show HSET VOLUME TEST.)
- k. Press and release the hookswitch. A continuous tone is broadcast over the handset receiver using the primary voice path. (Display keysets show TX/RX VOICE TEST.)
- l. Press and release the hookswitch. The handset transmitter is connected to the handset receiver via the primary voice path. (Display keysets show HOT HANDSET TEST.)
- m. While speaking into the handset transmitter, determine that sidetone is being received over the handset receiver.

- n. Press and release the hookswitch. The speakerphone microphone is connected to the handset receiver. (Display keysets show SPKRPHN MIC TEST.)
 - o. While speaking into the speakerphone microphone (or rubbing a finger over the opening to the microphone), determine that the sound is being broadcast over the handset receiver.
 - p. Place the handset back in its cradle. The keyset rings momentarily and it takes about ten seconds for the keyset to return to normal operation. (Display keysets show TEST COMPLETED for about five seconds. Then, the system date and time is displayed.)
 - q. Replace the keyset if faulty.
 - r. Replace the baseplate.
- (9) The keyset ring tone (GLX-Plus Keysets) or ring pitch (Executive Keysets) can be changed by performing the steps described in the FEATURES section on page 4-8.
- (10) After the system has been programmed, check that the keysets function properly.

Headsets

7.5 Refer to SPECIFICATIONS, page 2-10, for headset requirements. To attach a headset to a keyset:

- (1) Remove the coiled handset cord from the handset jack on the base of the keyset. (On GLX-Plus Keysets, you will first need to remove the base-

plate to expose the control board.) Leave the handset in the cradle.

- (2) Insert the headset modular plug into the jack. Plug in the headset power source, if used.
- (3) If the headset has an on/off switch, turn on the headset.

Handset Amplifiers

7.6 Users may wish to have a handset amplifier installed. Typically, the amplifier is an external unit that is placed between the keyset and the handset (refer to page 2-10 for specifications).

7.7 To install such an amplifier:

- (1) Unplug the coiled handset cord from the keyset. (On GLX-Plus Keysets, you will first need to remove the baseplate to expose the control board.)
- (2) Plug the coiled handset cord into the amplifier jack labeled HANDSET.
- (3) Plug the amplifier line cord (coming from the jack labeled TELEPHONE) into the keyset handset jack.
- (4) Plug the amplifier power supply cord into an AC outlet.
- (5) Turn on the amplifier.
- (6) The handset volume can be increased or decreased, using the thumbwheel located on the amplifier. Verify that the amplifier is functioning correctly by placing a call and adjusting the volume from low to high.

Wall Mounting Keysets

7.8 To mount the keyset on a wall (refer to Figure 3-16 below):

- (1) Remove the keyset baseplate and set the keyset aside.
- (2) Rotate the baseplate so that the mounting holes are at the top. Position the plate in the desired location on the wall.
- (3) Mark the location of the keyset mounting holes on the wall. Set the baseplate aside.
- (4) Drive a #8 pan-head screw (or proper hardware for the wall) into the center of each mounting hole marking. The head of the screw should protrude approximately $\frac{1}{4}$ - to $\frac{1}{2}$ -inch (0.6 to 1.2 centimeters).
- (5) Replace the baseplate on the keyset with the mounting holes toward the top.
- (6) Mount the keyset on the wall. Adjust the screws if necessary to ensure that the keyset is securely mounted.

FIGURE 3-16. WALL MOUNT THE KEYSET

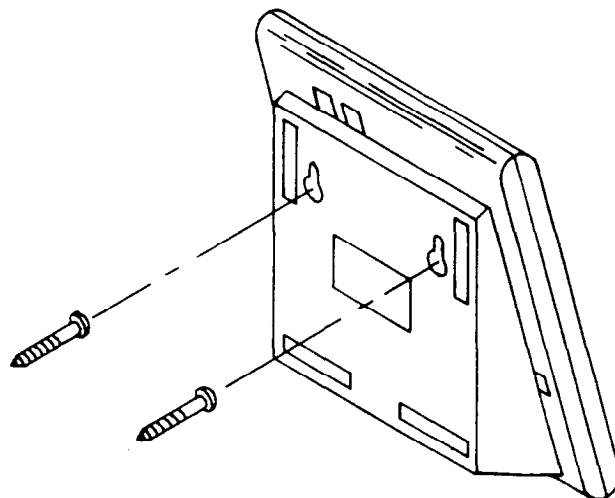
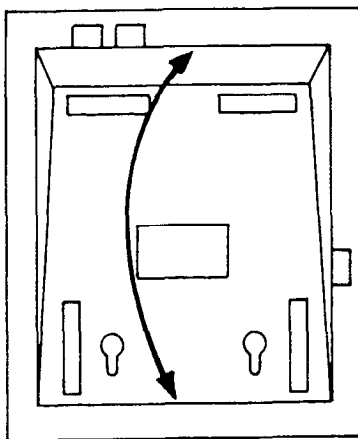

Optional Data Port Module For GLX-Plus Keysets

7.9 GLX-Plus Keysets may be equipped with optional Data Port Modules (part number 828.1094). The Data Port Module contains a four-conductor modular jack that can be used to connect *either* a data device (such as a personal computer with a direct-connect modem) *or* an LRA and an external signaling device (such as a loud bell, horn, flashing light, etc.) to the keyset.

7.10 Install the Data Port Module as outlined below. For a diagram, see Figure 3-17 on page 3-28.

- (1) Remove the keyset baseplate.
- (2) Unplug the line cord from its modular jack.
- (3) Remove the 10-pin shorting plug located on the keyset control board.
- (4) Save the shorting plug by taping it to the inside of the baseplate. The plug must be replaced if the Data Port Module is later removed.
- (5) Align the Data Port Module over the three posts protruding from the inside of the baseplate and insert the screws (do not over tighten).
- (6) Plug the Data Port Module cable into the pins on the keyset control board (where the shorting plug was previously located). Make sure the cable connector is securely seated.
- (7) Place jumper straps SP1, SP2, SP3, and SP4 on the Data Port Module in the appropriate positions. Depending on how the Data Port Module will be used, refer to one of the two possible settings outlined in Figure 3-17.
- (8) *If connecting a modem-equipped data device, refer to paragraphs 7.11 through 7.13.*

If connecting a loud ringing adapter and an external signaling device, refer to paragraphs 7.14 through 7.16.

7.11 To connect a modem-equipped data device: The optional Data Port Module on GLX-Plus Keysets and the ancillary jack (labeled DATA) on Executive Keysets can be used to connect a data device (such as a personal computer) equipped with a direct-connection modem to a keyset. The data device can be used with the keyset to communicate with remote data equipment over voice channels being used for CO or intercom calls. The data device's modem must be externally powered (or capable of operating on 20mA of loop current) and have an RJ11 CO trunk interface.

7.12 The keyset is used to dial an outside or intercom number; the keyset user then presses the DATA key to connect the CO line or intercom channel to the data device. While the data device is connected to a CO line or intercom channel, the keyset user cannot place or receive calls. (For details on using the data connection, refer to page 4-10 in FEATURES).

7.13 Install the data device as follows:

- (1) Insert the modem line cord (which would normally be connected to a CO jack) into the modular jack on the Data Port Module (or into the DATA jack on Executive Keysets).
- (2) Ensure that the jumper straps on the Data Port Module are set to the proper *data device* positions. Refer to Figure 3-17.
- (3) Plug the keyset line cord into the keyset's modular jack and reattach the baseplate.

FIGURE 3-17. GLX-PLUS KEYSSET DATA PORT MODULE INSTALLATION

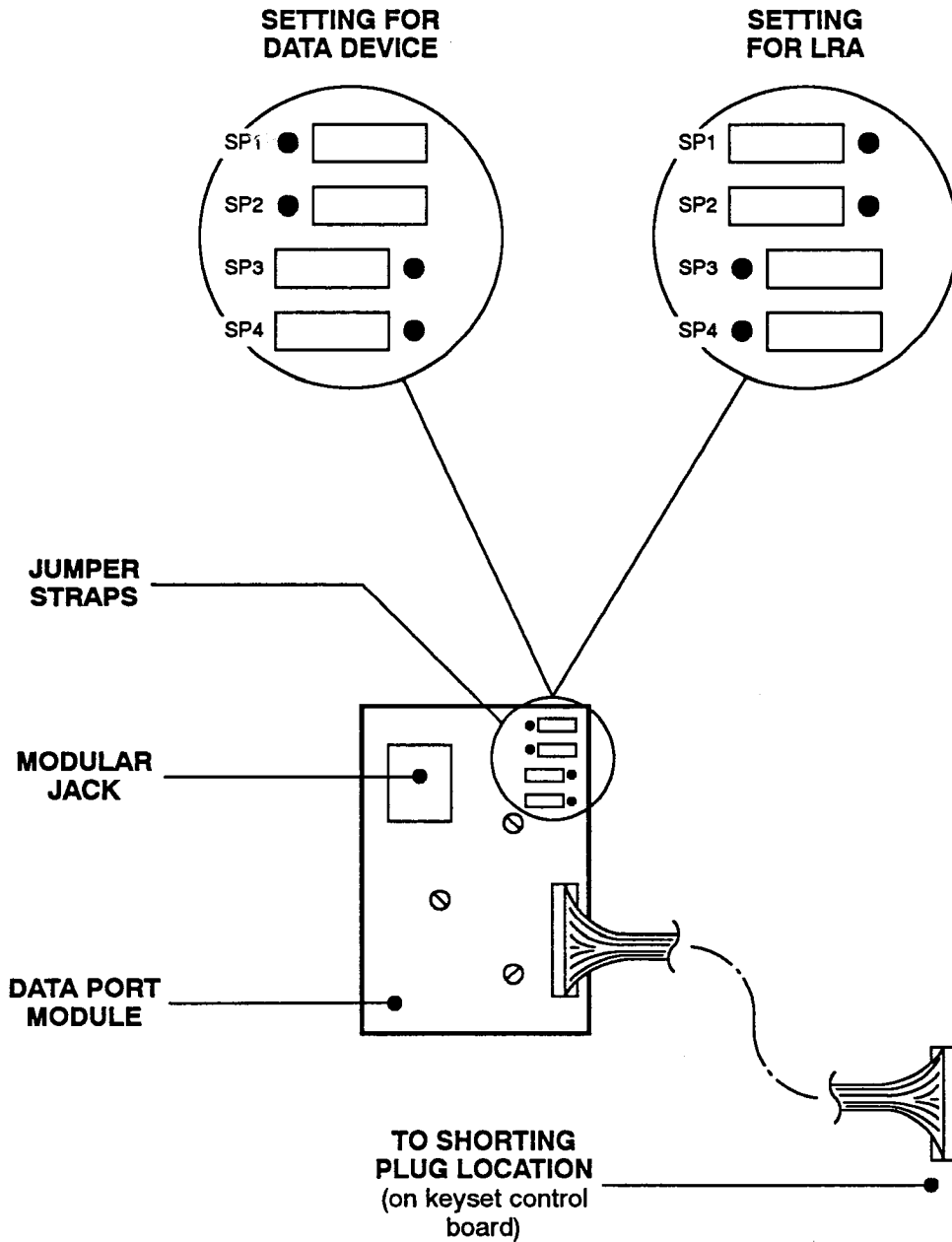

7.14 To connect a Loud Ringing Adapter (LRA): The optional Data Port Module on GLX-Plus Keysets and the ancillary jack (labeled DATA) on Executive Keysets can be used to connect external signaling equipment such as loud bells, horns, flashing lights, etc. to a keyset. This application is useful in areas where the normal ring tone of the keyset cannot be heard, such as warehouses and loading docks. The signaling device follows the normal ringing patterns of the keyset.

NOTE: Since handsfree intercom calls may be difficult to hear in noisy areas, keysets with LRAs installed should be programmed for ring intercom first so that users are alerted to incoming intercom calls by continuous ringing. (See FEATURES, page 4-16.)

7.15 An electromechanical LRA device is placed between the keyset and the external signaling equipment to provide the necessary interface relay. Refer to page 2-10 for LRA device specifications and recommendations. A diagram of a typical set-up is shown in Figure 3-18 below.

7.16 Install the LRA as follows:

- (1) Using 24AWG wire, connect the LRA device input (coil circuit) to the RED and GREEN wires on a modular jack assembly. Some devices re-

quire that polarity be observed between the LRA input and the modular jack.

NOTE: In order for the LRA device to operate properly, the maximum resistance from the modular jack to the LRA should be kept under 100 ohms.

- (2) Attach a mod-to-mod line cord to the modular jack assembly and to the modular jack on the Data Port Module (or DATA jack on Executive Keysets).
- (3) Ensure that the jumper straps on the Data Port Module are set in the proper LRA positions. Refer to Figure 3-17 on the previous page.
- (4) Connect the LRA device output (contacts) to the signaling device according to the manufacturer's instructions. Use the appropriate gauge wire for handling the current/voltage rating of the signaling device.
- (5) Plug the keyset line cord into the modular jack on the back of the keyset and reattach the baseplate.
- (6) While on hook, enter the LRA feature code (#05) to enable the LRA. (The display shows: LRA TOGGLED and the DATA key is lit.) See page 4-11 for additional information.

FIGURE 3-18. LRA SET-UP

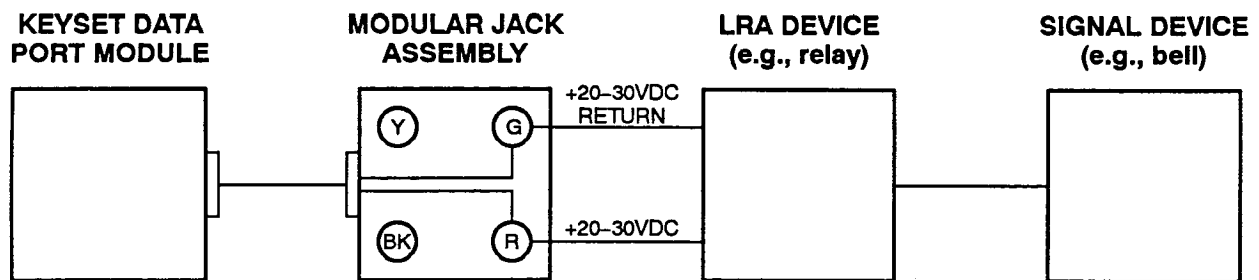

NOTE: Each time the keyset rings, the Data Port Module provides 20-26mA of loop current to the LRA. This causes the LRA contacts to close and activates the signaling device. The LRA is not affected by the ring tone or the ringer volume of the keyset. The LRA must be capable of operating on 20mA current (approximately 20VDC).

GLX-Plus Keypad Battery Back-Up

7.17 GLX-Plus Keypads can be equipped with optional date, time, and volume setting battery back-up using a battery connection kit (828.1239) and a customer-provided 9V battery. (Refer to page 2-11 for more information.)

- (1) Unpack the battery connection kit. There should be a battery clip, a two-wire battery strap, and two small pieces of double-sided foam tape (one piece is a spare).
- (2) Remove the keypad baseplate and set the keypad aside.
- (3) If an optional Data Port Module is installed, temporarily remove it for easier battery installation.
- (4) Remove the backing from one side of a piece of foam tape and attach it to the inside of the baseplate. (See Figure 3-19 below.)

NOTE: To allow room for an existing or future Data Port Module, position the tape as close to the top of the arch as possible.

- (5) Attach the battery strap to the terminals of a 9V battery and insert the battery into the metal battery clip.
- (6) Remove the backing from the other side of the foam tape (installed in step 4). Then attach the battery clip to the tape so that the open end of the clip is facing up.

NOTE: Position the clip and battery as close to the top of the arch as possible.

- (7) If necessary, replace the Data Port Module.
- (8) Attach the free end of the battery strap to connector J3 on the keypad control board.
- (9) Reattach the baseplate being careful not to pinch the battery strap.

FIGURE 3-19. GLX-PLUS KEYPAD BATTERY BACK-UP

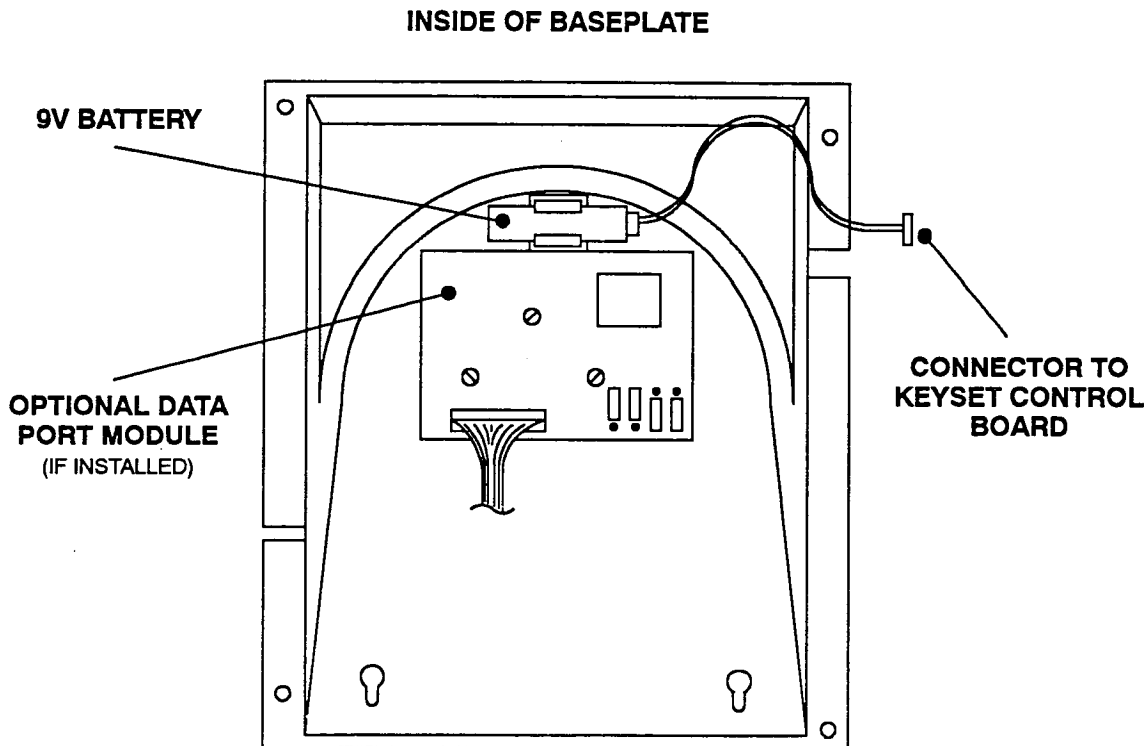

B. SINGLE-LINE SET INSTALLATION

7.18 Up to two industry-standard, AC-ringing, DTMF single-line sets may be connected to the KSU if the optional Accessory Port Module is installed.

7.19 To install a single-line set:

- (1) Before connecting a single-line set to the system, measure the voltage on the RED terminal of the modular jack assembly with respect to the GREEN terminal. (The common probe of the voltmeter is placed on the GREEN terminal.) It must measure between -22VDC and -36VDC. If a positive voltage is measured, check the cabling for a reversed pair.
- (2) Mount the modular jack assembly on the wall.
- (3) Plug one end of the line cord into the modular jack assembly and plug the other end into the jack on the single-line set.

8. EXTERNAL PAGING EQUIPMENT INSTALLATION

8.1 A jack on the right side of the KSU is the output for the optional external paging equipment. Refer to Figure 3-20 on the next page. Install the external paging equipment as follows:

- (1) Cut a length of shielded speaker cable (or coaxial cable) to run from the paging amplifier to the KSU.
- (2) Attach a $\frac{1}{8}$ -inch mini-phone plug to one end of the cable.
- (3) Connect the other end of the cable to the amplifier high-impedance input according the manufacturer's instructions.
- (4) Insert the plug into the KSU jack labeled E-PAGE.
- (5) Connect the speaker(s) to the amplifier, using speaker cable.
- (6) Plug in the amplifier's AC power cord. *DO NOT* use the outlet for the KSU.
- (7) Set the amplifier volume control to the lowest setting and turn on the amplifier.

- (8) From a keyset, make a page by lifting the handset and pressing the E-PAGE key. Adjust the amplifier to the desired level while placing the page.

9. EXTERNAL MUSIC SOURCE INSTALLATION

9.1 A jack on the right side of the KSU is the input for the optional external music source (radio, tape player, etc.). Refer to Figure 3-20 on the next page.

NOTE: In some circumstances, there may be broadcast restrictions associated with the music. Check with the music's original distributor and/or the radio station for copyright and broadcast restrictions concerning background music and music-on-hold.

9.2 If using a radio as a music source, place it 5 to 10 feet away from the KSU to avoid RFI generated by the KSU. If the radio is placed more than 10 feet away from the KSU, use twisted-pair cable. For better reception, a radio with an external antenna is recommended.

- (1) Attach the RCA-type phono plug to one end of a 5- to 10-foot (1.5- to 3.0-meter) length of coaxial cable.
- (2) **EITHER**, connect the other end of the cable to the speaker output terminals of the music source.

OR, if the music source has an earphone jack, attach an $\frac{1}{8}$ -inch mini phone plug (or other specified connector) to the other end of the cable, and plug it into the earphone jack on the music source.

NOTE: If the earphone jack is "padded" so that the optimal volume level cannot be reached, the *EITHER* procedure may be more effective.

- (3) Insert the phono plug into the KSU jack labeled MUSIC.
- (4) Plug in the AC power cord for the music source. *DO NOT* use the outlet for the KSU.
- (5) Turn on the AC power to the music source.
- (6) From a keyset, select a CO line and dial the telephone number of one of the other lines to call back into the system. Put the call on hold to hear the music. Adjust the volume on the music source to the desired level. The optimum input level is 1.0VRMS (0dB).

FIGURE 3-20. CONNECT THE EXTERNAL EQUIPMENT

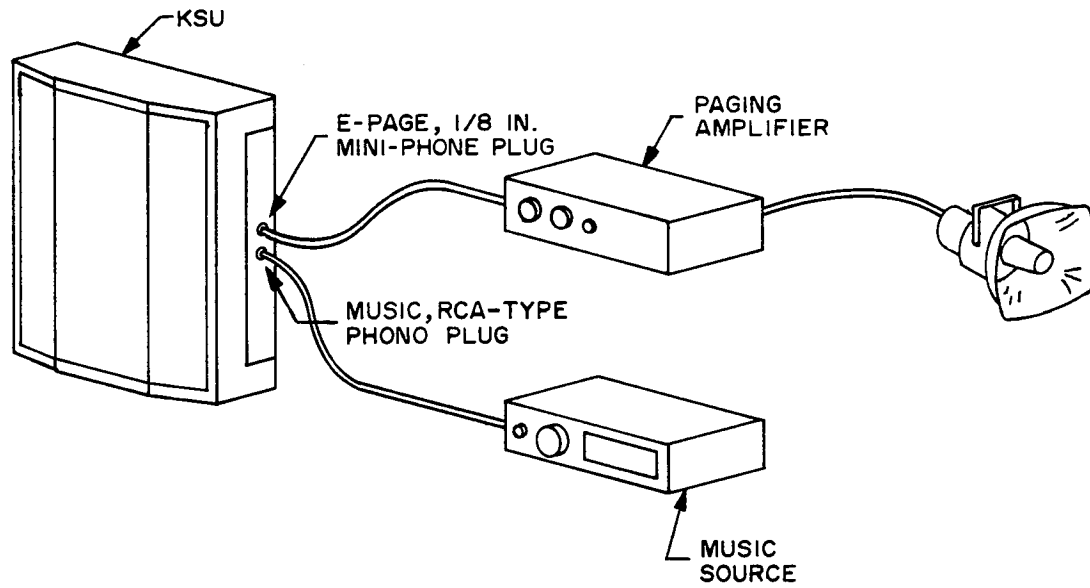

10. BATTERY BACK-UP EQUIPMENT

10.1 The GLX-Plus System can be equipped with optional system battery back-up using an uninterruptible power supply or a standby power supply. (Refer to page 2-12 for specifications.)

10.2 To install an uninterruptible power supply (UPS) or standby power supply (SPS) unit, follow these steps:

- (1) Turn the KSU AC power switch (PWR) to the OFF position and unplug the AC power cord.
- (2) Plug the UPS/SPS unit into the KSU AC outlet.
- (3) Plug the surge/spike protector into the UPS/SPS unit.
- (4) Plug the KSU AC power cord into the surge/spike protector.
- (5) Turn the KSU and UPS/SPS unit power switches to the ON positions.

11. POST-INSTALLATION CHECKLIST

11.1 To ensure that the system has been installed properly, review the installation outline on page 3-2. Then review the items in the following list as a final check.

- KSU location, station locations, and cable runs meet environmental requirements and cable lengths are within loop limits.
- Bridging clips are installed where required on all MDF blocks.
- Gas discharge tubes with silicon avalanche suppressors are installed on the CO lines for lightning protection. Also, if extra protection is desired, the cable between the telephone company RJ-type block and the gas discharge tubes is at least 75 feet long.
- The KSU is attached to an approved earth ground.
- The system power supply is plugged into an isolated, dedicated AC outlet, and no other equipment has been plugged into the same outlet. An extension cord was *not* used. A voltage surge/spike protector is installed to reduce the effects of AC voltage surges and spikes that can cause system malfunctions, false logic, and/or damage to the electronic components.
- Amphenol-type connectors, modular jack connectors, and station instrument line cords are all connected securely. All keyset and single-line stations are working properly.
- All optional equipment is properly installed and working correctly (for example, radio is tuned to a station, etc).
- CO dial tone is present and calls can be placed and received using all CO lines.

FEATURES

<i>CONTENTS</i>	<i>PAGE</i>
1. Introduction	4-3
2. Feature Keys And Codes	4-3
3. CO Line Features	4-4
A. Dual-Tone Multi-Frequency (DTMF) Or Dial-Pulse Signaling	4-4
B. Flexible Incoming Ring Assignment (Alternate Point Answering)	4-4
C. Flexible Night Ringing Arrangement (Night Ring Mode)	4-4
D. CO Line Restriction And Station Toll Restriction	4-4
4. Protection Against Power Failure	4-5
5. Station Instruments	4-6
A. Keysets	4-6
B. Single-Line Sets	4-12
C. Voice Mail Unit	4-12
D. Doorbox Units	4-13
6. Signals And Tones	4-14
A. Ring Signals	4-14
B. Call Processing Signals	4-14
7. Music-On-Hold And Background Music	4-15
8. Intercom Calls	4-16
A. Private Intercom Calls	4-16
B. Keypad Handsfree Enable/Disable	4-16
C. Station-To-Station Calling	4-16
9. Outside Calls	4-18
A. Placing Outside Calls	4-18
B. Receiving Outside Calls	4-18
C. Account Codes (Keysets Only)	4-19
D. Busy CO Line Callback (Queue)	4-20
E. Outside Dial Tone Restore	4-20
F. Line Key Skipping (Keysets Only)	4-21
G. Night Security Code (Keysets Only)	4-21
10. Placing Calls On Hold	4-22
A. System Hold (Keysets Only)	4-22
B. Individual Hold	4-22
C. Consultation Hold (Single-Line Stations Only)	4-22
D. Hold Recall	4-22
11. Call Waiting	4-23
12. Call Transfer	4-24

<i>CONTENTS</i>	<i>PAGE</i>
13. Call Pick-Up (Reverse Transfer)	4-24
14. Paging	4-25
15. Call Forwarding	4-26
16. Privacy Release	4-29
17. Call Privacy Restore (Executive Or GLX-Plus Keysets Only)	4-29
18. Conference Calls (Keysets Only)	4-30
A. Placing A Conference Call	4-30
B. Exiting A Conference	4-30
19. Speed Dialing (Keysets Only)	4-32
A. Station Speed Dialing	4-32
B. System Speed Dialing	4-32
C. Speed Dialing Special Common Carrier (SCC) Numbers Stored In Separate Locations	4-33
20. Do-Not-Disturb (Keysets Only)	4-33
21. Redialing (Keysets Only)	4-33
22. Time And Date Display Programming (GLX-Plus Keysets Only)	4-34
23. SMDR Device Station	4-35
A. Station Message Detail Recording (SMDR)	4-35
B. Database Reports	4-38
24. System Attendant Station	4-43
A. Attendant Recall	4-43
B. Placing The System In Night Mode	4-43
C. Night Security Code	4-43
D. Programming System Speed-Dial Numbers	4-44

1. INTRODUCTION

1.1 The GLX-Plus System has many easy-to-use features. This section describes the features and provides detailed instructions on their use. Refer to the user guides for simplified instructions on using station features.

2. FEATURE KEYS AND CODES

2.1 Keysets have feature keys that allow one-key access to the station features.

2.2 At keyset stations, most of the station features are selected using the feature keys. Other features require the user to enter a feature code. The feature codes that are used at keyset stations to enable and disable station features include the following:

- Call Forward If No Answer/Busy ... #01
- Call Forward Unconditional #02
- Do-Not-Disturb #03
- Headset #04
- Background Music #06
(Executive and GLX-Plus keysets have a feature key for background music.)

2.3 There are three additional feature codes:

- Executive and GLX-Plus keysets can use the Privacy Enable feature code (SPCL 8)

- Executive keysets, and GLX-Plus keysets that are equipped with Data Port Modules, can use the Loud Ringing Adapter (LRA) feature code (#05) to enable and disable the LRA.

- GLX-Plus keysets can have customized date/time displays using the Date/Time Display feature code (SPCL 4) and a series of programming routines

2.4 One station can be designated as the SMDR device station. That station uses special codes to generate SMDR reports and database programming reports. The SMDR station and its codes are explained on page 4-35.

2.5 Single-line stations use the following feature codes:

- Callback (Queue) *#
- Cancel Callback **
- Call Forward *01
- Cancel Call Forward *11
- Program Call Forward Destination .. *04
- CO Hookflash *05
- Individual Hold *14
- Internal Page *71
- External Page *72
- Reverse Transfer *4X
(X represents a CO line number 1-6)
- CO Line Access 9X
(X represents a CO line number 1-6)

3. CO LINE FEATURES

3.1 This section explains the CO line functions and programmable features.

NOTE REGARDING CO LINE SECURITY

While this system is designed to be reasonably secure against CO line misuse by outside callers, there is no implied warranty that it is invulnerable to unauthorized intrusions and toll fraud. If the central office does not provide supervision, and disconnect the call when one party hangs up, it is possible for a caller to remain connected to a CO line circuit. If this happens, and the caller begins dialing, the call could be placed through the GLX-Plus System and would then be billed to the system's owner. The system cannot check this type of call for toll restriction. This problem could arise when a call is connected to a station, when a call is in an unsupervised conference calls.

The GLX-Plus System does not have loop current detection capabilities. Therefore, disconnect supervision or any drop in loop current will not cause the GLX-Plus to drop the CO line connection. The GLX-Plus user must hang up when completing a call. If a call has been forwarded to the public network, the Forward To The Public Network timer will limit the duration of the call and disconnect the line when the timer expires. If an answering machine is connected to an APM, it may be necessary to set a maximum record time.

A. DUAL-TONE MULTI-FREQUENCY (DTMF) OR DIAL-PULSE SIGNALING

3.2 The system can be installed with either DTMF or dial-pulse lines. Dial-pulse lines must be specially designated in database programming, because all lines are designated as DTMF when the system is initialized.

3.3 When using dial-pulse signaling, DTMF tones are not transmitted over the CO line when the keypad keys are pressed. To use DTMF tones while on a dial-pulse line, the user can temporarily convert the keyset to DTMF signaling by pressing the asterisk (*) key at any time after the pulse-dialed digits have been sent over the CO line. (If the user switches to DTMF while the pulse-dialed digits are being sent, the system will wait until the last pulse-dialed digit has been sent before switching and sending the first DTMF digit.) This application is useful when the user must dial out on a dial-pulse line

and then communicate with a computer or other device that recognizes DTMF tones.

3.4 As the user dials a telephone number manually or uses speed dial or redial on a dial-pulse line, the system stores the digits in a buffer for conversion to dial-pulse signals. The user then hears the digits being sent out as the system dials the number. The speed at which the system sends the digits is determined by the Pulse-Dial Speed and Pulse-Dial Interdigit timers. These timers are programmable and can be adjusted to meet the specifications of the central office.

B. FLEXIBLE INCOMING RING ASSIGNMENT (ALTERNATE POINT ANSWERING)

3.5 When the system is initialized, only the attendant's station (intercom number 10) rings for incoming calls on the CO lines. However, the associated line key flashes on all keysets and any keyset user may answer an incoming call by pressing flashing line key. Single-line set users can use the call pick-up (reverse transfer) feature to pick up ringing calls (see page 4-24). Using station feature programming, CO lines can be programmed to ring in on any or all stations. CO lines can ring in at any station, without ringing in at the attendant's station.

C. FLEXIBLE NIGHT RINGING ARRANGEMENT (NIGHT RING MODE)

3.6 CO lines that ring in at the attendant's station can be programmed to ring in at one or more alternate stations when the system is placed in night ring mode. Refer to page 5-12 in PROGRAMMING for more information. CO lines that are not programmed to ring in at the attendant's station are not affected by night ring mode and continue to ring in as programmed. Attendant recalls continue to ring at the attendant's station when the system is in night ring mode.

D. CO LINE RESTRICTION AND STATION TOLL RESTRICTION

3.7 As a means of restricting outgoing calls, stations can be prevented from having access to one or more CO lines for placing calls. This is performed during station feature programming. Users attempting to place a call using a restricted CO line hear a busy signal; however, they can answer incoming calls, calls on system hold, or recalls on the restricted CO lines.

3.8 As a means of controlling costs, the system can be programmed to restrict specific stations from being used to dial toll calls. The toll restrictions and exceptions include:

- Basic Toll Restrictions
- Allow System Speed-Dial Numbers to Bypass Toll Restriction
- Exclude CO Line(s) from Toll Restriction

Basic Toll Restrictions

3.9 There are three system programming options available that are used with station option 6 (toll restrict) to cause the system to analyze and/or count the digits dialed at the station.

- System option 1 prevents a station user from placing a call when the number dialed has "0" or "1" as the first digit. If the first digit is a "0" or "1", the call is dropped immediately. System option 1 is enabled during initialization. System speed-dial numbers are not toll restricted when system option 4 is enabled.
- System option 2 prevents a station user from placing a call when the number dialed begins with a "0" or "1", or when the number exceeds eight digits. If the first digit is a "0" or a "1", the call is dropped immediately; if the call exceeds eight digits, it is dropped when the ninth digit is dialed. The eight-digit limit is in effect throughout the call. If a ninth digit is dialed while the call is in progress, the call is dropped. System speed-dial numbers are not toll restricted when system option 4 is enabled.
- System option 3 is identical to option 2 except that a station user may dial directory assistance (1411, 1-555-XXXX, XXX-555-XXXX, or 1-XXX-555-XXXX), emergency (1911), and toll-free (1-800-XXX-XXXX or 800-XXX-XXXX) numbers.

3.10 If more than one of the above options are enabled, the system only checks the lowest-numbered option. If a restriction is found, the call is dropped even if there are other options remaining. Selecting no options during programming disables the toll restriction feature.

Allow System Speed-Dial Numbers to Bypass Toll Restriction

3.11 System option 4 permits system speed-dial numbers to bypass the toll restrictions enabled by option 1, 2, or 3. (However, any digits dialed after the speed-dialed number *are* checked for toll restriction.) Because this option is an exception to the other options, it is never used by itself.

Exclude CO Line(s) from Toll Restriction

3.12 The system can be programmed to allow access to one or more CO lines for placing calls that would otherwise be denied by system option 1, 2, or 3. The unrestricted CO line can be a local line, WATS line, FX line, PBX line, etc.

4. PROTECTION AGAINST POWER FAILURE

A. DATABASE BATTERY BACK-UP

4.1 The Main Control PCB contains a lithium battery that protects the programmed database, system and station speed-dial numbers, redial memory, and call forward requests in the event of a power failure. Headsets, do-not-disturb, background music, and the data device interface are returned to default status (disabled) if a power failure occurs. The battery can protect the database for 10 years of normal system operation, or until the accumulated system downtime exceeds one year.

B. POWER FAILURE BACK-UP

4.2 To provide back-up power in the event of an AC power failure or brownout condition, the GLX-Plus System power supply can have optional battery back-up using a customer-provided uninterruptible power supply (UPS) unit or a standby power supply (SPS) unit. Refer to page 2-12 for details.

C. GLX-PLUS KEYSSET BATTERY BACK-UP

4.3 Each GLX-Plus Keypad is equipped with its own internal clock. On display keysets, the clock can be set to show the current date and time. If the keypad is unplugged or loses power, the date and time display defaults to "00:00 MON JAN 01" and must be reprogrammed.

4.4 In addition, each GLX-Plus Keypad also has VOL UP and VOL DN keys that allow the user to individually control and save speakerphone, handset, and ring tone volume levels. If the keypad is unplugged or loses power, the all saved volume levels return to the default settings.

4.5 To preserve the date and time display and the volume control settings during a power interruption, each GLX-Plus Keypad may be equipped with optional battery back-up using a battery connection kit (828.1239) and a customer-provided 9V battery. Refer to page 3-30 for installation instructions.

5. STATION INSTRUMENTS

5.1 To allow system flexibility and cost efficiency, a variety of station instruments can be used on the GLX-Plus System. They are:

- Standard Keysets
- Executive Keysets
- GLX-Plus Keysets — display and non-display
- Industry-standard, AC-ringing, single-line, dual-tone multi-frequency (DTMF) sets

A. KEYSETS

5.2 The Executive and GLX-Plus keysets differ from the Standard Keyset in that they have additional feature keys and Direct Station Selection/Busy Lamp Field (DSS/BLF) keys. Executive keysets have a jack for connecting a data device or loud ringing adapter; GLX-Plus keyset can be equipped with an optional Data Port Module for that purpose. GLX-Plus Display Keysets also can have an optional one-line, 16-character liquid crystal display.

5.3 The GLX-Plus keyset is a special type of keyset that contains an audio-integrated module which allows the user to adjust volume levels independently for pages, calls, ring tones, etc. Throughout the manual, whenever the word "keyset" is used, it includes GLX-Plus keysets (unless stated otherwise).

Handsfree Speakerphone

5.4 Every keyset has an integrated speakerphone that allows handsfree operation on outside calls and handsfree answering of intercom calls. The speakerphone is automatically activated by incoming intercom calls or when a line key is pressed while the keyset is on hook. The ON/OFF key is used to transfer the voice path between the handset and the speakerphone and to hang up from handsfree calls.

5.5 There are two keyset programming options that can affect the speakerphone. Keyset option 2 disables the handsfree feature on incoming intercom calls. Keyset option 4 disables the feature that automatically activates the speakerphone when a line key is pressed. With either option enabled, the ON/OFF key is used to control the speakerphone.

5.6 All keyset stations allow the user to dial while on hook. In addition, the keyset speaker may provide background music (if an external music source is installed) and is used to receive pages.

Line Keys

5.7 The six CO line keys provide direct access to the CO lines. Each line key is equipped with an LED that indicates the status of the CO line (in use, holding, recalling, etc.).

Feature Keys

5.8 The keys found on all keysets are described below:

KEY	FUNCTION
ON/OFF	Controls the speakerphone or headset for handsfree operations. Disconnects a CO line when dialing on hook.
SPDL	Stores and dials speed-dial numbers. Inserts pauses in speed-dial numbers. When used with the asterisk (*) key on a Standard Keyset, redials the last number dialed.
CNF	Places call on conference hold, then establishes a conference.
SYS HOLD	Places an outside call on system hold. When used with the asterisk (*) key at the attendant's keyset, places the system in night ring mode.
PAGE	Initiates an internal page.
E-PAGE	Initiates an external page.

5.9 The following keys are found on the Executive and GLX-Plus keyset only:

KEY	FUNCTION
BGM	Allows music to be heard through the speakerphone.
DATA	Connects the data device (computer, data terminal, etc.) while on a CO or intercom call.
SPCL	Signals the system that a special feature code is about to be entered.
FLASH	Sends a timed hookflash to select PBX or telephone company features, or releases and re-seizes a CO line.
REDL	Redials the last number dialed.
HOLD	Places an outside call on individual hold.

Keypad Light-Emitting Diode (LED) Indications

5.10 The keypad line keys and feature keys (except PAGE and E-PAGE) are equipped with LEDs. The LED flash rates, shown in the table below, indicate the status of the stations, CO lines, and features. The rates are shown in interruptions per minute (IPM).

	STEADY 0 IPM	CONSTANT FLUTTER 300 IPM	MEDIUM FLASH 60 IPM	DOUBLE FLASH 60 IPM	SLOW FLASH 30 IPM	FLUTTER WITH PAUSE 30/300 IPM
ON/OFF	Speakerphone or headset is in use					
SPDL	Speed-dial number being dialed	Speed-dial number is being programmed				
SYS HOLD	Your keypad is in do-not-disturb		Your keypad is in call forward mode		An intercom call is waiting Or, if this is the attendant station, the system is in night mode	
CNF	Keypad in conference		Unsupervised conference in progress			
BGM*	Background music on					
REDL*	Number being redialed					
DATA*	LRA mode enabled				Data device is in use	
Line Keys	Line is in use	A call is recalling the attendant on this line	A call is on system hold from another keypad	A call is on individual, system, or conference hold at this keypad	A call is ringing in on this line	A call is recalling from hold on this line

*On Executive and GLX-Plus keypads only

Direct Station Selection/Busy Lamp Field (DSS/BLF) Keys

5.11 The Executive and GLX-Plus keysets have 12 DSS/BLF keys that provide one-key intercom access to each of the 12 stations. The LEDs under the DSS/BLF keys create a busy lamp field and flash at different rates to indicate the status of each station. Each flash rate has a distinct meaning, as described below. Flash rates are given in interruptions per minute (IPM) or seconds on/off.

FLASH RATE	INDICATION
STEADY (constantly lit)	The station is busy.
LOCK-OUT FLASH (0.5 sec. on/ 3.5 sec. off)	The station is in lock-out (off hook with no activity) or unplugged. When a station is causing lockout flash, press the associated DSS/BLF key on any Executive or GLX-Plus keyset. Canceling DSS/BLF lockout flash on one keyset cancels the DSS/BLF flash on all Executive and GLX-Plus keysets. Also, placing the handset on hook at the locked-out station will cancel the flash.
SLOW FLASH (30 IPM)	An outside call is recalling. (1.0 sec. on/1.0 sec. off)
DND FLASH (3.5 sec. on/ 0.5 sec. off)	The station is in do-not-disturb.
MEDIUM FLASH (60 IPM)	The station is in call forward mode.

Automatic Line/Intercom Call Access

5.12 This keyset option (programmed through the keyset features program) allows the user to answer any outside or intercom call that is ringing in to the station by simply lifting the handset. Intercom calls that would normally be received handsfree still automatically activate the speakerphone, even if the keyset is ringing.

NOTE: Initializing the database disables this feature.

5.13 If more than one call is ringing at a time, they are picked up in the following order:

- Private intercom calls
- Direct ring-in

- Transferred calls
- Recalls
- Busy line callbacks (queues)

5.14 If more than one call of the same type is ringing, the lowest-numbered line is chosen first.

5.15 Camped-on calls cannot be answered by simply lifting the handset or pressing the ON/OFF key.

Selectable Ring Tone (GLX-Plus and upgraded Executive and Standard keysets only)

NOTE: If the ring pitch does not change when using this procedure on an Executive or Standard keyset, it is an older version keyset that has not been upgraded and does not support this feature.

5.16 The pitch of ring signals can be changed on keysets to create distinctive ringing. If stations are placed close together, changing the pitch makes each station's ring easier to recognize. The ring pitch is changed by pressing keys on the keypad.

5.17 When the system is initialized, all keysets are set to the highest frequency (800Hz).

5.18 TO CHANGE RING PITCH AT AN EXECUTIVE OR GLX-PLUS KEYSSET STATION:

NOTE: The KSU PRG EN switch must be in the OFF position.

- (1) While on hook, dial #07.
- (2) Dial the two-digit code (00-15) for the desired ring pitch. The display shows RING TONE: XX. The keyset will ring at the selected pitch for 1.5 seconds to confirm the entry.

NOTE: On GLX-Plus keysets, ring tone selection 15 is for silence. You will not hear a ring tone, but you will receive the confirmation tone after performing step 4. When the station receives a call, the keyset will not ring. However, the line key will flash and the display will show the incoming call. If an LRA is connected, the keyset will not ring, but the LRA will receive the ring signal.

- (3) You may press the asterisk (*) key to change to the next higher pitch or the pound (#) key to change to the next lower pitch. Each time you change pitch, the keyset will ring for 1.5 seconds.
- (4) Lift and replace the handset. You hear a confirmation tone.

Volume Controls

5.19 On Standard and Executive Keysets, speaker volume and ring tone volume are controlled by two thumbwheels on the right-hand side of the keyset.

5.20 On GLX-Plus Keysets, volume is controlled by pressing volume control feature keys (labeled VOL UP and VOL DN) on the keyset.

5.21 TO CHANGE VOLUMES ON A GLX-PLUS KEYSSET:

- (1) While performing or listening to any of the following functions, press the VOL UP key to increase the volume *OR* press the VOL DN key to decrease the volume:
 - a. Handset calls (changes handset voice and progress tone volume levels)
 - b. Speakerphone calls or background music (changes handsfree voice, music, and progress tone volume levels)
 - c. Ringing through the keyset speaker (changes ringing alert tone volume level)
- (2) *If desired*, press the VOL UP and VOL DN keys at the same time to save the new volume level for the particular function. If this step is not performed, the keyset will retain the previous saved volume level for that function (except for the ringing alert tone volume, which is automatically saved at the most current volume level).

Headset Connection And Operation

5.22 A headset may be attached to any keyset. The ON/OFF key, which is used to turn the headset on and off, is lit when placing and receiving calls and unlit when the headset is not in use. The Standard and Executive Keysets are compatible with industry-standard, four-conductor, modular headsets that have dynamic microphones, or carbon-microphone headsets that are connected to the keyset through an externally powered jackset (which makes the headset dynamic-compatible). The GLX-Plus Keyset is compatible with industry-standard, four-conductor, modular headsets that have electret microphones. Refer to page 3-25 for installation instructions.

NOTE: The speakerphone cannot be used when a headset is enabled (feature code #04 has been entered).

5.23 TO CONNECT A HEADSET:

- (1) Disconnect the headset by unplugging the coiled handset cord from the base of the keyset. Leave the headset in the cradle.
- (2) Insert the headset plug into the vacant handset jack.
- (3) While on hook, dial #04 to enable the headset feature. The display shows: HEADSET TOGGLED.

5.24 TO DISCONNECT THE HEADSET:

- (1) Reattach the headset.
- (2) While on hook, dial #04 to disable the headset feature. The display shows: HEADSET TOGGLED.

Data Device Interface (Executive Or GLX-Plus Keypad Only)

5.25 The Executive keysets have a four-conductor, modular jack (labeled DATA) that can be used for connecting a data device (such as a data terminal or personal computer) that has a direct-connection modem with an RJ11 CO line interface. The GLX-Plus keypad can be equipped with a Data Port Module that provides a modular jack for this purpose.

5.26 The keypad is used to dial an outside or intercom number; the keypad user then presses the DATA key to connect the CO line or intercom channel to the data device.

5.27 While the data device is connected to a CO line or intercom channel, the keypad user cannot place or receive calls. The keypad appears busy for incoming intercom calls. If an outside call rings in or an intercom call camps on to the busy keypad, the call waiting signals will not interfere with the data transmission.

5.28 TO CONNECT THE DATA DEVICE TO EXECUTIVE OR GLX-PLUS KEYPAD:

- (1) Locate the interface cable coming from the data device. If necessary, refer to the device's user manual for the location of the cable. The RJ11 connector on the end of the cable must be compatible with the keypad DATA jack.
- (2) Insert the connector end of the data device interface cable into the keypad DATA jack.

5.29 TO CALL A REMOTE COMPUTER USING A CO LINE:

- (1) Lift the handset and press an unlit line key.
- (2) Dial the telephone number of the computer to be called.
- (3) When you hear the modem tone, press the DATA key. The DATA key flashes slowly.
- (4) Replace the handset and operate the data device according to the manufacturer's instructions.

5.30 TO ALLOW YOUR COMPUTER TO DIAL THE NUMBER WHEN USING A CO LINE:

- (1) Lift the handset and press an unlit line key.
- (2) Press the DATA key.
- (3) Following the instructions for your computer's communications software, instruct your computer to dial the telephone number of the computer to be called. The DATA key flashes slowly.

5.31 TO CALL A REMOTE COMPUTER USING AN INTERCOM CHANNEL:

- (1) Lift the handset and press the desired DSS/BLF key.
- (2) Notify the called party that you wish to connect the data device.
- (3) When the called party activates the remote computer and presses the DATA key, you hear modem tone. Press your DATA key. Both DATA keys flash slowly.
- (4) Replace the handset and operate the data device according to the manufacturer's instructions.

5.32 TO TERMINATE THE CONNECTION WITH THE COMPUTER:

EITHER, press the DATA key. The CO line or intercom channel is disconnected and the DATA key is unlit.

OR, if you wish to speak to the party at the computer site after the data has been transmitted, lift the handset and press the data key. This can only be done if the modem at the computer site can be turned off without dropping the CO line.

Loud Ringing Adapter (LRA)

5.33 The Executive keysets have a modular jack (labeled DATA) that allows the user to connect external signaling equipment such as loud bells, horns, flashing lights, etc. to the keyset. The GLX-Plus keyset can be equipped with a Data Port Module that provides a modular jack for this purpose (see pages 3-27 and 3-29 in INSTALLATION). This application is useful in areas where the normal ring tone of the keyset cannot be heard, such as warehouses and loading docks. The signaling device follows the normal ringing patterns of the keyset.

5.34 Keysets with an LRA attached should be programmed for ring intercom first so that users are alerted to incoming intercom calls by continuous ringing (hand-

free intercom calls may be difficult to hear in noisy areas).

5.35 TO ENABLE THE LRA:

While the keyset is on hook, dial #05 to enable the LRA. The display shows: LRA TOGGLED. The DATA key will light while the LRA is enabled.

NOTE: The DATA port cannot be used for other features while the LRA is connected.

5.36 TO DISABLE THE LRA:

While the keyset is on hook and idle, enter #05 again. The display shows: LRA TOGGLED. You do not have to disconnect the LRA relay and signaling device, unless you wish to use the DATA port for another feature. The DATA key is unlit.

B. SINGLE-LINE SETS

5.37 AC-ringing single-line sets can be installed on GLX-Plus Systems that are equipped with an Accessory Port Module (APM). For details on installing an APM, refer to SPECIFICATIONS and INSTALLATION.

5.38 The APM supplies two single-line ports for the GLX-Plus System. These ports can support industry-standard, AC-ringing 2500 sets and a variety of single-line devices such as modems and facsimile machines. The single-line port extension numbers are 20 and 21.

5.39 Special single-line port programming is performed through the single-line stations and stored in the APM memory. Refer to page 5-12 in PROGRAMMING for details. Single-line programming options include the following:

- **Call Waiting Tones:** Call waiting tones can be disabled for each single-line port. This prevents call interruptions when a device such as a modem or a facsimile machine is attached. When the tones are disabled and a modem or FAX device is connected to a single-line port, incoming calls will not have call waiting tones interfering with the call.
- **Ring Cadence:** Some FAX machines cannot recognize the standard intercom ring cadence of the GLX-Plus System. This option allows the ring cadence to be extended when a FAX is attached to the single-line port. Not all FAX machines have the same tolerances for ring cadence detection.
- **Single-Line Minimum Hookflash Timer:** This timer controls the minimum length of time that a single-line station must stay on hook for a hookflash to be recognized by the APM software. A hookflash shorter than this timer will be ignored by the APM software.
- **Single Line Maximum Hookflash Timer:** This timer controls the maximum length of time that a single-line station can remain on hook for a hookflash to be recognized by the APM software. If the station remains on hook longer than this timer, the call is disconnected.
- **Single-Line Port dB Padding:** When connected to an APM port, some single-line devices can produce distorted DTMF signals which may not be detected by the central office or the GLX-Plus KSU. If desired, the audio path (transmit and receive) for the APM port can be attenuated by 3 dB. When the APM is initialized, the dB padding is disabled.

C. VOICE MAIL UNIT

5.40 A voice mail unit can be installed on one or both single-line ports of an APM. There are no programming requirements in the GLX-Plus System to designate a single-line port as a Voice Mail Port. Simply connecting the unit to the single-line port will allow voice mail operation.

5.41 GLX-Plus keysets and single-line sets can be used to make direct intercom calls to the voice mail system, as they generate the necessary DTMF tones on intercom calls. Executive and Standard keysets must use a CO line to call back in to the system to reach the voice mail unit.

5.42 If both single-line ports are used for voice mail applications, the first voice mail port should be set to Forward — No Answer/Busy to the second voice mail port. The second port should also be set to Forward No Answer/Busy to the first port creating a type of "hunt group." The extension number of the first voice mail port would be the initial voice mail extension number. The hunt group would then function as follows:

- When the first port is busy, intercom and transferred outside calls will camp-on, until it becomes available.
- Whenever the first port is busy, direct ring-in calls are automatically sent to the second voice mail port, and if idle, the second voice mail port will answer the call. If the second port is also busy, the following will occur:
 - Intercom calls will camp on. When a port becomes available, the intercom call will ring at that port.
 - Transferred outside calls will camp on to the second port until it becomes available. It will not go back to the first port, even if that port becomes available. If unanswered before the Attendant Recall timer expires, it will recall the attendant's station.
 - A direct ring-in outside call will hunt between the two ports until it is answered or the caller hangs up. It will not recall the attendant.
- If the outside caller hangs up before a voice mail port answers, the line will continue to ring as though the caller is still connected. An available voice mail port will have to answer the call in order to disconnect it (because the GLX-Plus does not monitor loop current, it cannot see the drop in loop current from the outside party disconnect). This can cause the voice mail to answer ringing calls that are not real. In order for this type of call to be disconnected from the GLX-Plus System, the voice mail must have the ability to detect dial tone (if still present by the time

the voice mail port answers the call) and disconnect the call or transfer it to the attendant's station after a timeout.

Forwarding To Voice Mail

5.43 All types of station devices may be forwarded to voice mail. However, when outside calls are forwarded and connected to the voice mail system, the GLX-Plus System will not automatically dial the forwarding station's extension number to reach a personal mailbox. The outside caller will receive the initial system greeting from the voice mail and must dial the mailbox number of the person they are trying to reach.

5.44 If an intercom call follows the forward path and is connected to voice mail, the intercom caller must be using a GLX-Plus keyset or a hand-held DTMF generator to be able to select the voice mail features.

Call Transfer From Voice Mail

5.45 If a voice mail system has the ability to perform hookflashes, the voice mail unit can transfer outside calls to the GLX. Depending upon the voice mail system's capabilities, Automated Attendant, pager, and various other voice mail features may also be used to interface with the GLX. The voice mail system must be capable of detecting ring tone by ring cadence, not ring voltage, when the voice mail system places a call to an intercom station. Refer to the voice mail system's manuals for system capabilities and operation.

5.46 If a voice mail system is set up to transfer outside calls to the GLX-Plus System, then all GLX-Plus stations should have the station option Ring Intercom First

enabled so that the initial intercom call from the voice mail unit is placed as a private call.

Call Transfer To Voice Mail

5.47 Only Executive keysets and GLX-Plus keysets can transfer outside calls to voice mail. Transferring calls to the voice mail is handled in the same manner as transferring calls to any other station. The transferring party should not dial the mailbox number, but should instruct the outside party that they will need to dial the specific mailbox number once they have been connected to the voice mail and receive the voice mail system greeting. This will ensure that the outside party will hear the complete mailbox personal greeting. (If the transferring party dials the mailbox number they will begin to hear the personal greeting before completing the transfer and the outside caller will miss hearing a portion of the greeting.)

D. DOORBOX UNITS



5.48 A doorbox can be installed to provide intercom access to a location outside the building. Refer to SPECIFICATIONS, page 2-12, for details.

5.49 When a person outside the building presses a button on the doorbox, the associated CO line rings in. By answering the ringing line, a station user can talk with the person at the door. If the door is equipped with an electric strike plate, the system user may allow access by dialing a code or pressing an external button. To call the doorbox, a station user can lift the handset and press the line key assigned to the unit.

6. SIGNALS AND TONES



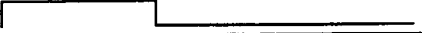





A. RING SIGNALS

6.1 The system signals and tones generated by the ringer or keyset speaker are as follows.

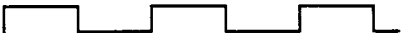
TYPE OF CALL	SIGNAL
Outside call or recall from hold	Single long tone every six seconds 
Intercom call	Two short tones and a pause (repeats for private calls) 
Queue callback	A repeating signal of three short tones and a long pause 

B. CALL PROCESSING SIGNALS

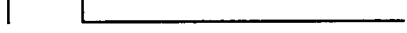
6.2 The following signals and tones are heard through the handset or keyset speaker.

SIGNAL	ACTION
Intercom dial tone 	Handset lifted or ON/OFF or IC key pressed.
Double tones (called station receives the same signal) 	Intercom call — repeats for private call or call to non-handsfree station; one double tone for handsfree call.
Intercom busy signal — slow repeating tones (until camp on) 	Called station or selected CO line is busy. You are restricted from using the CO line selected. All conference circuits are busy when you attempt to establish a conference with an outside call.
A repeating signal of four fast tones and a pause 	Called station is in do-not-disturb.
Reorder tones — fast tones (may be four tones or continuous) 	You dialed an invalid or unequipped intercom number. Your station is toll restricted. The Inactivity timer expired. Another station is camped on to the busy station you are calling. All intercom channels are busy. All conference circuits are busy when you attempt to establish a conference with an intercom call. Call forward cannot be completed.
Triple ring tone every 15 seconds 	Unsupervised conference you initiated is still in progress.
One triple ring tone 	You have selected the paging network.
Single progress tone 	Feature procedure completed, or a code needs to be entered.
Call waiting tone — single tone every six seconds 	An intercom or outside call has camped on to your station.

7. MUSIC-ON-HOLD AND BACKGROUND MUSIC

7.1 The system can be equipped with an external music source (radio, tape player, etc.) for calls on hold and calls waiting. This feature not only makes the wait as pleasant as possible, but it assures the waiting party that the call is still connected.

NOTE: In some circumstances, there may be broadcast restrictions associated with the music heard by callers on hold. Check with the music's original distributor and/or the radio station for copyright and broadcast restrictions concerning music-on-hold.

7.2 There are two music-on-hold channels for outside calls on hold. When both channels are in use, a third outside call on hold will not receive music. A channel is considered in use as long as the call is in progress, even after the call is no longer on hold. This ensures that an

outside caller who has received music will hear music if the call is placed on hold again.

7.3 Camped-on intercom calls always receive music if the music source is installed. Music can also be heard through the keysets' speakers, using the Background Music feature code (or BGM key on the Executive and GLX-Plus keyset). Background music is interrupted when the keyset is in use, being programmed, ringing, or receiving a page.

7.4 *TO TURN MUSIC ON OR OFF (STANDARD KEYSET):*

While on hook, dial #06.

7.5 *TO TURN MUSIC ON OR OFF (EXECUTIVE OR GLX-PLUS KEYSET):*

While on hook, press the BGM key. The display shows: BGM ENABLED or BGM DISABLED. The BGM key lights when music is on.

NOTE FOR SINGLE-LINE SET USERS: When the procedures tell you to hookflash, quickly press and release the hookswitch. If you press the hookswitch to hang up, hold it down until the SL Hookflash Maximum timer expires (default value is 0.7 seconds); otherwise, the system recognizes it as a hookflash.

8. INTERCOM CALLS

8.1 The intercom can be used to place station-to-station calls that can be answered handsfree at keyset stations. Or, it can be used to place private (non-handsfree) calls. A station user that reaches a busy station can camp on and wait for the station to become available. Other features that apply to both outside and intercom calls, as described later in this section of the manual, include placing calls on hold, call waiting, conferencing, do-not-disturb, and call forwarding.

NOTE: Integrated speakerphones, which allow handsfree operation on outside calls and intercom calls, are standard on keysets.

8.2 The GLX-Plus System has two intercom channels that allow station users to place calls to one another. Intercom calls can be placed by dialing a two-digit intercom number (10-21), pressing a DSS/BLF key on an Executive or GLX-Plus keyset, or dialing 0 to call the attendant. Intercom numbers are assigned to stations in the order that the station cables are connected to the KSU (refer to page 3-10).

A. PRIVATE INTERCOM CALLS

8.3 A station user can place private (non-handsfree) intercom calls by pressing 8 key before dialing the extension number or pressing the DSS/BLF key. Or, the station can be programmed to always receive private calls using station option 2 "ring intercom first."

B. KEYSET HANDSFREE ENABLE/DISABLE

8.4 A keyset user can always receive private calls by disabling the keyset handsfree answering feature by enabling keyset option 2. The keyset user hears repeating double tones when receiving an intercom call and must lift the handset (or press the ON/OFF key) to answer while this feature is enabled.

A. STATION-TO-STATION CALLING

Receiving Intercom Calls

8.5 TO RECEIVE AN INTERCOM CALL ON A KEYSET:

If you hear a double tone and a call announcement (handsfree call) and the display indicates an incoming call, and the ON/OFF key is lit, respond handsfree or lift the handset.

If you hear repeating double tones (private call) and the display indicates an incoming call, lift the handset. Or press the ON/OFF key to respond handsfree.

8.6 TO RECEIVE AN INTERCOM CALL ON A SINGLE-LINE SET:

When you hear repeating double tones, lift the handset.

Placing Intercom Calls

8.7 A keyset user can place intercom calls without lifting the handset, using the integrated speakerphone. This method allows the user to speak handsfree once the call is connected. (If the keyset speakerphone preselect feature has been disabled by keyset option 4, you must press the ON/OFF key to turn on the speakerphone before you can dial an intercom number.)

NOTE: When placing an intercom call, begin dialing before the Dial Initiation timer expires. If the timer expires, the system drops the connection and sends repeating reorder tones. This prevents a voice channel from being tied up accidentally.

8.8 TO PLACE AN INTERCOM CALL (OFF HOOK):

- (1) Lift the handset.
- (2) *If you want to place a private (non-handsfree) call to a keyset, press 8.*
- (3) Dial an extension number or press a DSS/BLF key. The number can be 0 for the attendant or a station extension number. If you dial too slowly, the Interdigit timer may expire and you will hear repeating reorder tones. The display shows EXT XX or the number dialed.
 - a. *If calling a handsfree keyset station, speak after you hear a double tone.*
 - b. *If placing a private call, calling a single-line station, or calling a keyset with handsfree disabled, you hear repeating double tones until the call is answered.*
 - c. *If you dial an invalid number or all intercom channels are busy, you hear repeating reorder tones.*

d. *If the called station is busy, you have the following options:*

1. Hang up and try later. *If dialing handsfree (keysets only), press the ON/OFF key to disconnect.*
2. Do not hang up, your call camps on and you hear music. When the called station is available, a private call is placed. Refer to page 4-23 for details. If the station has a previous intercom call waiting, you hear a continuous fast busy signal.

e. *If you hear a repeating signal of four fast tones and a pause, the station is in do-not-disturb. Hang up and try again later.*

8.9 TO DIAL AN INTERCOM CALL WHILE ON HOOK (KEYSETS ONLY):

- (1) While on hook, dial an intercom number or press a DSS key. (If you wish to place a private call, dial 8 before the intercom number or DSS key.) The ON/OFF key lights and your call is connected.
- (2) When the called party responds, you may speak handsfree or lift the handset for privacy. (If volume levels cause feedback to occur, one station user should lift the handset.)

NOTE: At any time during a handsfree call, you may lift the handset for a private conversation. To return to the speakerphone, press the ON/OFF key and replace the handset.

- (3) To disconnect, press the ON/OFF key (if on hook) or hang up (if off hook).

DSS/BLF Key Skipping (Executive Or GLX-Plus Keypad Only)

8.10 Executive and GLX-Plus keysets have DSS/BLF keys that can be used to place intercom calls. If the user presses a DSS/BLF key while on an intercom call, the current call is dropped and a call is placed to the station associated with the pressed DSS/BLF Key. This is faster than pressing an releasing the hookswitch and then pressing the desired DSS/BLF Key.

8.11 TO USE DSS/BLF KEY SKIPPING:

When you are finished with an intercom call and wish to place another intercom call, do not hang up. Press the DSS/BLF key of the party you wish to call. You are disconnected from the first call and hear the second call ring as usual.

NOTE: Pressing a DSS/BLF Key and hanging up while on an outside call transfers the outside call to the called station. Refer to page 4-24.

9. OUTSIDE CALLS

9.1 When a CO line is selected for receiving or placing an outside call, the voice channel is seized and cannot be used by any other station (unless privacy release is enabled, see page 4-29, or conferencing is used, see page 4-30). If the desired CO line is busy, the station user can request a callback (queue) if privacy release is not enabled. Other features that apply to both outside and intercom calls are discussed later in this section of the manual. They include placing calls on hold, call waiting, call transfer, conferencing, and call forwarding.

A. PLACING OUTSIDE CALLS

9.2 A keyset user can place an outside call without lifting the handset, using the integrated speakerphone. This method allows the user to speak handsfree once the call is connected.

NOTE: If your keyset speakerphone has been disabled by station option 4, you must press the ON/OFF key to turn on the speakerphone before you press the unlit line key.

9.3 TO PLACE AN OUTSIDE CALL:

NOTE: When placing a call, begin dialing before the Dial Initiation timer expires. If the timer expires, the system drops the CO line connection and sends repeating reorder tones. This prevents a CO line from being tied up accidentally.

- (1) **Keyset:** Lift the handset or remain on hook.
Single-Line: Lift the handset.
- (2) **Keyset:** Press a line key to select an outgoing CO line. The line key is lit. (If on hook, the ON/OFF key is lit.)

Single-Line Set: Dial a Line Access code (91-96).

NOTE: You must have outgoing access to a CO line to seize it.

- (3) You hear one of the following signals:
 - a. **Outside dial tone:** Manually dial, speed dial, or redial the desired telephone number. (The display shows the numbers dialed and then the call duration.) *If you hear repeating reorder tones and the line is disconnected, you dialed a restricted number. Also, if you dial too slowly and the Interdigit timers expire, the call may be dropped, and you will hear repeating reorder tones. If on hook, you may lift the handset to speak privately.*
 - b. **Repeating reorder tones:** You are restricted from the CO line chosen; choose another CO line.

B. RECEIVING OUTSIDE CALLS

9.4 TO RECEIVE AN OUTSIDE CALL:

Keyset:

When you see a slow-flashing line key, hear a ring signals, and/or see a display showing CO LINE RINGING, lift the handset and press the slow-flashing line key. The call is connected and the line key is steadily lit.

Single-Line Set:

When you hear ring signals, lift the handset; you are connected to the caller.

C. ACCOUNT CODES (KEYSETS ONLY)

9.5 Account codes can be used in conjunction with the SMDR feature to provide a tracking system for calls. When an account code is entered during an outside call, the code is recorded and will appear in the SMDR printout when it is generated.

9.6 The user may re-enter an account code as many times as desired while on the outside call. This gives the user the ability to correct entry mistakes or to change the code if desired. If more than one account code is entered during a call, the last code entered will be recorded in the SMDR printout.

9.7 While the account code is being entered at an Executive or Standard keyset, the caller hears confirmation tones as the digits are pressed. If an Executive or Standard keyset user enters an account code after the line is selected, before the number is dialed, the confirmation tones will not be detected by the central office.

9.8 When a GLX-Plus keyset is used for entering an account code, the caller does not hear any indication that the account code is being entered. If a GLX-Plus keyset user enters an account code after the line is selected, before the number is dialed, the DTMF tones are muted until after the call has been established.

9.9 To associate an account code with a conference call, the code must be entered before the conference is established.

9.10 *TO ENTER AN ACCOUNT CODE DURING AN OUTSIDE CALL:*

- (1) While on an outside call, press the SPDL key and then dial #. The display shows ACCT CODE.
- (2) Enter the account code (up to eight digits) within 10 seconds and then press *. The display shows the digits as they are entered. (If you enter more than eight digits, the first eight digits are accepted as the account code, the ninth digit will terminate the account code entry, and all further digits will be heard over the conversation as DTMF digits.)

9.11 *TO ENTER AN ACCOUNT CODE BEFORE DIALING AN OUTSIDE CALL:*

- (1) Lift the handset.
- (2) Press the SPDL key and then dial #. The display shows ACCT CODE.
- (3) Enter the account code (up to eight digits) within 10 seconds and then press *. The display shows the digits as they are entered. (If you enter more than eight digits, the first eight digits are accepted as the account code, the ninth digit will terminate the account code entry, and all further digits will be ignored.)
- (4) Select an outgoing line and dial the number as usual.

D. BUSY CO LINE CALLBACK (QUEUE)

NOTE: This feature is available on systems programmed for call privacy. If the system is programmed for privacy release it only applies to: calls that use a conference circuit, forced private calls, data calls, and calls on individual hold.

9.12 If you attempt to select a busy outgoing CO line and hear a busy signal, you can request a callback (queue) and hang up until the system signals your station that line is available. You may request one callback from each of the lines at a time. You may request callbacks on any or all of the six lines, if busy.

9.13 Callbacks must be answered within 15 seconds. If a callback is not answered, the request is canceled. If the station is busy when called back, the request is placed at the top of the queue list and the line is made available to the next station on the list. If a station receives a ring-in call and a callback simultaneously, on the same line, the ring-in call takes priority and the station remains at the top of the queue list. Callbacks will not follow forwards and are not blocked by placing the station in do-not-disturb.

9.14. TO QUEUE A BUSY OUTGOING CO LINE:

- (1) When you hear a busy signal while selecting a CO line, press the pound (#) key.
- (2) Hang up if off hook. If you are on the speakerphone, the keyset turns off automatically.
- (3) Your station rings (a repeating signal of three tones and a long pause) and the display shows **LINE AVAILABLE** when the queued CO line is available. Select the line as usual, within 15 seconds.

9.15 TO CANCEL A QUEUE BEFORE THE CALLBACK:

- (1) **Keyset:** Press the line key of the line for which you are waiting.
Single-Line Set: Lift the handset and enter the Line Access code for the line for which you are waiting.
- (2) When you hear busy tones, press the asterisk (*) key. You hear a single tone. (You will hear reorder tones if you did not have an active callback request for that line.)

E. OUTSIDE DIAL TONE RESTORE

9.16 The GLX-Plus System is designed to send a timed hookflash when the keyset user presses the line key, an Executive or GLX-Plus keyset presses the **FLASH** key, or a single-line set user enters the CO Hookflash feature code while on an outside call. This allows the user to disconnect from one call and restore dial tone on the same CO line to place a second call. This is faster than pressing and releasing the hookswitch and then pressing the line key to make a call. The duration of the hookflash is controlled by the programmable CO Flash timer (refer to page 5-8).

9.17 A timed hookflash may also be required when the system is used behind a PBX system or to select telephone company features such as call waiting or call forwarding. If so, the station user follows the instructions given below when a hookflash is needed.

9.18 TO RESTORE OUTSIDE DIAL TONE:

Keyset: After you are finished with the call, do not hang up. Press the same line key (or **FLASH** key on an Executive or GLX-Plus keyset). You hear dial tone and can place an outgoing call.

Single-Line Set: After you are finished with the call, do not hang up. Perform a hookflash and then enter the CO Hookflash feature code (*05).

F. LINE KEY SKIPPING (KEYSETS ONLY)

9.19 Line key skipping allows keyset users to disconnect from one outside call and select another CO line by pressing another line key. This is faster than pressing and releasing the hookswitch and pressing a line key. If the system is used behind a PBX, this feature will gain access to PBX dial tone instead of CO dial tone.

9.20 TO USE LINE KEY SKIPPING:

After you are finished with an outside call, do not hang up. Press an unlit line key to place another call. Or press a flashing or fluttering line key to answer a ringing, holding, or recalling outside call. The selected line key lights.

G. NIGHT SECURITY CODE (KEYSETS ONLY)

9.21 The GLX-Plus System can be programmed with the following night security code options:

- **Option 5** — Users must enter a night security code to place toll calls while the system is in night mode: When this option is enabled, all stations are changed to toll class 3 (all toll calls are restricted) whenever the system is placed in night mode. Entering the four-digit night security code returns the station to its normal toll restriction status.
- **Option 7** — Users must enter a night security code to place any calls while the system is in night mode: When this option is enabled, all stations are changed to complete line restriction (no outside calls are allowed) whenever the system is placed in night mode. Entering the four-digit night security code returns the station to its normal toll restriction/outgoing line access status.

9.22 The system is programmed to require a night security code when placing toll calls by entering option 5

while programming system options. Or, it can be programmed to require a night security code when placing any outside call by entering *both* option 5 and option 7 while programming system options.

9.23 The night security code options do not affect the manner in which incoming calls are answered. Direct ring-in calls, holding calls, transfers, and recalls are all answered as usual.

9.24 If system speed-dial numbers are programmed to bypass toll restriction, that option is disabled when the night security code is in effect. Also, line that are flagged as "not subject to toll restriction" will be subject to toll restriction when the night security code is enabled.

9.25 When the system is initialized, the security code is 9999. The attendant's station can be used to reprogram the code. Any combination of digits, asterisks (*), and pounds (#) can be used as part of the code, but *, #, 0, 1, 2, or 8 cannot be used as the first digit.

NOTE: Initializing the system disables this feature and returns the security code to 9999.

9.26 TO USE THE NIGHT SECURITY CODE AT A STATION:

While on hook, enter the programmed four-digit security code. (Display shows NITE SEC TOGGLE for five seconds.) You hear four short tones followed by a confirmation tone and you may place your call.

9.27 With either of the night security code options, the user can return the station to night security mode by entering the four-digit code a second time. The station will also be returned to night security mode if the system is removed from night mode and then placed in night mode again.

10. PLACING CALLS ON HOLD

10.1 There are three ways to place outside calls on hold: system hold, individual hold, and consultation hold. While on hold, callers hear music, if available. The automatic recall timers limit the amount of time a call can remain on hold (refer to paragraph 10.10).

A. SYSTEM HOLD (KEYSETS ONLY)

10.2 System hold is available to all keyset users. The keyset user who put the call on hold sees a double-flashing line key; other keyset users see a medium-flashing line key. Any keyset user can pick up a call that was placed on system hold.

10.3 TO PLACE A CALL ON SYSTEM HOLD:

While on an outside call, press the SYS HOLD key. You hear intercom dial tone and see a double-flashing line key.

10.4 TO PICK UP A CALL ON SYSTEM HOLD:

While on or off hook, press the double-flashing or medium-flashing line key.

B. INDIVIDUAL HOLD

10.5 Individual hold is available to all stations except Standard keyset stations. It differs from system hold in that calls placed on individual hold are accessible only from the station where the call was placed on hold. Other keysets show a steadily lit line key, which indicates a busy CO line that cannot be selected.

10.6 TO PLACE A CALL ON INDIVIDUAL HOLD:

Keyset: While on an outside call, press the HOLD or I-HOLD key. You hear intercom dial tone and the line key double flashes.

Single-Line Set: While on an outside call, hook-flash and then enter the Individual Hold feature code (*14).

10.7 TO RETURN TO THE CALL ON INDIVIDUAL HOLD:

Keyset: Lift the handset and press the double-flashing line key.

Single-Line Set: Lift the handset and enter the Individual Hold feature code again (*14).

C. CONSULTATION HOLD (SINGLE-LINE STATIONS ONLY)

10.8 Consultation hold allows a single-line set user to pause during an outside call, enter a feature code if desired, and then return to the call. Intercom calls cannot be placed on consultation hold.

10.9 TO USE CONSULTATION HOLD:

- (1) While on an outside call, hookflash to place the call on consultation hold.
- (2) You can do one of the following:

If you wish to transfer the call, dial an extension number and hang up.

*If you wish to place the call on individual hold, enter the Individual Hold feature code (*14).*

If you wish to return to the caller on hold, hook-flash again.

NOTE: Once a call is on consultation hold, you must enter a feature code within 15 seconds. If you do not enter a feature code in this amount of time, you will hear reorder tones. If you hang up while a call is on consultation hold, the call will immediately recall your station. If the recall is not answered within 60 seconds, the call will recall the attendant (intercom number 10).

D. HOLD RECALL

10.10 Three timers ensure that calls placed on system hold or individual hold are not forgotten. They are the Hold Recall timer, the Attendant Recall timer, and the Attendant's Abandoned Call timer (refer to page 5-8 for information on programming the Recall timers).

10.11 If an outside call remains on hold until the Hold timer expires, it recalls the station. If it is still unanswered when the Attendant Recall timer expires, it recalls the attendant. If the attendant does not answer the recall before the Attendant's Abandoned Call timer expires (10 minutes), the call is disconnected by the system. Attendant recalls continue to signal the attendant's station when the system is placed in night ring mode. During a recall, the party on hold continues to hear music (if equipped) and does not hear the call ringing.

10.12 TO ANSWER A HOLD RECALL:

Keyset: You hear a ring tone every six seconds (and your DSS/BLF key flashes slowly on your keyset if you are using an Executive or GLX-Plus keyset). The display shows: CO LINE RINGING. The associated line key flutters on every keyset. Any keyset user can pick up the call by pressing the line key; you can press either the line key or your DSS/BLF key.

Single-Line Set: You hear a ring tone every six seconds. Lift the handset and you will be connected to the recalling call.

11. CALL WAITING

11.1 There are two types of call waiting: intercom call waiting and outside call waiting. An incoming intercom call or transferred outside call camps on and the caller hears music (if available) until the busy party hangs up; a direct outside call rings in and the caller hears ringing.

Intercom Call Waiting

11.2 The busy station user is alerted to the call waiting by a double ring tone every six seconds. Keypad users will see a slow-flashing SYS HOLD Key. The display shows: IC CALL WAITING.

11.3 *TO RESPOND TO AN INTERCOM CALL WAITING WHILE ON AN INTERCOM CALL:*

Keypad: Press the slow-flashing SYS HOLD key. You are disconnected from the current call and connected to the waiting call.

Single-Line Set: End the current call and hang up to allow the waiting call to ring in. Or end the call and perform a hookflash to disconnect from the current call and automatically answer the waiting call.

11.4 *TO RESPOND TO AN INTERCOM CALL WAITING WHILE ON AN OUTSIDE CALL:*

To disconnect from the current call: Hang up; the waiting intercom call rings in.

To place the current call on hold:

Keypads: Place the outside call on hold by pressing the slow-flashing SYS HOLD key. Executive and GLX-Plus keypad users can press the HOLD Key. The waiting intercom call is connected and the line key double flashes. To disconnect from the intercom call and reconnect to the outside call on hold, press the double-flashing line key.

Single-Line Set: Hookflash and enter the Individual Hold feature code (*14). The waiting call is connected.

Outside Call Waiting

11.5 The busy station user hears one short ring tone every six seconds. If the waiting call is a direct ring-in call, the keypad user sees a slow-flashing line key. If it is a transferred outside call, the user sees a double-flashing line key.

11.6 Single-line sets will receive call waiting signals when a transferred call is waiting, but will not be able to differentiate between a transferred call and a direct ring-in call. Therefore, when transferring to a busy single-line line set, the transferring party should allow the intercom call to camp on and be answered before completing the transfer. This also would allow the single-line user to place the current call on hold before receiving the transferred call. Single-line stations cannot place an outside call on hold while there is a transferred call waiting to be answered. In order to answer a waiting transferred call, the single-line station user would have to end the current call or transfer the current call to another station.

11.7 *TO ANSWER AN OUTSIDE CALL WAITING WHILE ON AN INTERCOM CALL:*

Keypad: Press the flashing line key. You are disconnected from the intercom call and connected to the waiting call.

Single-Line Set: End the current call. Then hang up to allow the waiting call to ring in, or perform a hookflash to automatically answer the waiting call.

11.8 *TO ANSWER AN OUTSIDE CALL WAITING WHILE ON ANOTHER OUTSIDE CALL:*

Keypad:

To disconnect from the current call: Press the flashing line key; you are disconnected from the current call and connected to the waiting call.

To place the current call on hold: Press the SYS HOLD or HOLD key to place the current call on hold. The line key for that call double flashes. Press the slow-flashing line key to answer the waiting call. To return to the holding call, press the double-flashing line key.

Single-Line Set:

To answer a direct ring-in waiting call: End the current call and hookflash, or place the current call on hold. The waiting call will be connected automatically. (If you placed the first call on hold, you cannot return to that call until the new call is disconnected.)

To answer a transferred waiting call: End the current call by hanging up; the waiting call rings in. Or, perform a hookflash and transfer the current call to another station; the waiting call is automatically connected.

12. CALL TRANSFER

12.1 All station users except Standard keyset users can transfer outside calls to other stations. The transferred party hears music, if available. The receiving party hears a ring tone every six seconds and sees a double-flashing line key. All other keyset users see a medium-flashing line key.

12.2 *TO TRANSFER AN OUTSIDE CALL USING AN EXECUTIVE OR GLX-PLUS KEYSET:*

- (1) While on an outside call, press the DSS/BLF key of the party that is to receive the transfer.
- (2) *If the receiving station is idle*, announce the call and hang up. The display shows: LINE TRANSFERRED. The receiving party sees a double-flashing line key and hears a long ring tone every six seconds. The receiving station's display shows CO LINE RINGING.

If the receiving station is busy, hang up. The display shows: LINE TRANSFERRED. The receiving party sees a double-flashing line key and hears short ring tone every six seconds. The receiving station's display shows CO LINE WAITING. When the busy party hangs up, the transferred call rings in.

12.3 *TO TRANSFER AN OUTSIDE CALL USING A SINGLE-LINE STATION:*

- (1) While on an outside call, hookflash to place the call on consultation hold.
- (2) Dial the intercom number of the party that is to receive the transfer.
- (3) *If you intercom call is answered*, announce the call and hang up. The call is transferred and rings at the receiving station (the line key shows the System Hold flash rate).

If the receiving station is busy, hang up. The call is transferred to the receiving station. The receiving party sees a double-flashing line key and hears short ring tone every six seconds. The receiving station's display shows CO LINE WAIT-

ING. When the busy party hangs up, the transferred call rings in.

If you need to reconnect to the call waiting to be transferred, hookflash twice. You will be connected to the call that you were transferring.

Transfer Recalls

12.4 If the transferred call remains unanswered at the receiving station until the Hold Recall timer expires, it recalls that station. If the recall is unanswered when the Attendant Recall timer expires, it recalls the attendant.

12.5 *TO ANSWER A TRANSFER RECALL:*

Keyset: You hear ring signals, the DSS/BLF key for your station flashes slowly, and the display shows INCOMING CO CALL. The associated line key flutters on every keyset. Any keyset user can pick up the call by pressing the fluttering line key. You can press the line key or DSS/BLF key.

Single-Line Set: When you hear a ring tone every six seconds, lift the handset. You are connected to the recalling party.

13. CALL PICK-UP (REVERSE TRANSFER)

13.1 Keyset users can pick up a call that is ringing or on system hold at another keyset by pressing the associated line key.

13.2 At single-line stations, a feature code must be entered to "reverse transfer" a direct ring-in call or call on system hold from another station (calls on individual hold cannot be reverse transferred to single-line stations). The feature code that is entered determines which line is picked up. The codes are *41 through *46. Feature code *41 picks up calls on line 1, *42 picks up line 2, and so on.

13.3 *TO REVERSE TRANSFER A CALL (SINGLE-LINE STATION ONLY):*

Lift the handset and enter the desired Reverse Transfer feature code (*41-*46). The call is automatically connected to your station.

14. PAGING

14.1 The paging feature allows announcements to be made through keyset internal speakers. Optional paging equipment (amplifiers and paging speakers) may also be installed to provide paging for an external area, such as a warehouse or loading dock (see *INSTALLATION*, page 3-31).

14.2 If desired, individual keysets can be removed from the internal paging zone by enabling keyset option 1 during keyset features programming. (Refer to page 5-12 in *PROGRAMMING*.)

14.3 Pages are not heard if the keyset is in do-not-disturb, is ringing, or is in use. Also, keyset background music is interrupted for pages.

14.4 TO MAKE A PAGE:

- (1) Lift the handset.
- (2) **Keyset:** Press the PAGE key for an internal page or the E-PAGE key for an external page.
Single-Line Set: Enter the feature code for Internal Page (*71) or for External Page (*72).
- (3) After the triple ring tone, make your page. The display shows: PAGE IN PROGRESS. If you hear reorder tones, the necessary system resources are busy, or the paging zone is being used by another station. Users cannot camp on to or queue the paging system.
- (4) Hang up.

15. CALL FORWARDING

15.1 With call forwarding, a keyset user can route incoming intercom and outside calls (including direct ring-in calls) to another station or, if the system has a CO line programmed for call forwarding, to an outside telephone number. Single-line set users can forward only to intercom numbers. A keyset user has a choice of two call forwarding options. Single-line set users can use only the no answer/busy option. The two forwarding options are:

- **Call forward unconditional/direct ring-in (keysets only):** All incoming intercom and outside calls are forwarded automatically to either an intercom number or an outside telephone number.
- **Call forward if no answer or busy:** Calls will be forwarded only when the station is in use or when there is no answer by the time the No Answer timer expires. Direct ring-in calls cannot be forwarded to outside telephone numbers using this feature.

15.2 The CO line ring-in assignment for the receiving station does not affect call forwarding. Even if the station does not audibly ring when receiving a direct ring-in call on a CO line, it *will* ring when receiving a forwarded call on that line.

15.3 When calling a forwarded station from a keyset, the calling keyset's SPDL and REDL keys light if an outside number is being dialed. The number is stored in redial memory on the caller's keyset.

15.4 Call forward requests can be chained from station to station. However, if call forward unconditional/direct ring-in forward requests form a loop (for example station 10 forwards to 11, and 11 to 10), the user cannot enter the forwarding code. When using the Call Forward If No Answer Or Busy code (#01), stations programmed to forward to each other will simply send the call back and forth between them (this can be used to create "hunt groups" for groups of stations that normally receive the same calls, such as a service department).

15.5 If more than one station has direct ring-in for a line and more than one has call forward enabled, the station with the lowest intercom number will control the direct ring-in calls for that line.

15.6 If the station that is programmed to receive your forwarded calls is placed in do-not-disturb, intercom callers will hear do-not-disturb signal when the call is forwarded. If one station in a forwarding chain is busy or in do-not-disturb, the system will bypass that station when forwarding a call.

15.7 If your station is in do-not-disturb and you have call forwarding programmed, the call is still forwarded.

15.8 Queue callbacks and recalls do not forward. If the attendant is forwarded, attendant recalls will ring at the station; if the Attendant's Abandoned Call timer expires (10 minutes) the call is disconnected.

Forwarding To An Outside Number (Keysets Only)

15.9 For calls to be forwarded to outside telephone numbers, a line must be set up as the call forward to the public network line. To allow calls to be forwarded to outside telephone numbers, you must also set up lines for call forward DIL diversion; this allows you to select the specific lines that will be allowed to forward calls to outside telephone numbers and exclude others, such as FX lines, WATS lines, and private lines.

NOTE: There *may* be some reduction in voice volume when an outside call is forwarded to an outside telephone number, depending on CO line quality.

15.10 If a call is transferred to a station that is forwarded to an outside number, the transferring party must wait for the outside line to be selected and for the outside telephone number to be dialed before completing the transfer. If the transferring party hangs up before the forward to the outside number can be completed, the transferred call will recall immediately.

15.11 A direct ring-in call can only be forwarded to an outside telephone number through the station where it rings in. If the station that receives the ring in is forwarded to a single station or chain of stations that is forwarded to an outside number, the direct ring-in call will remain at the last station in the chain that is forwarded to the outside number; it will not forward to the outside number. When a direct ring-in call is forwarded to an outside telephone number, the station that is forwarded cannot be used for placing or receiving other calls while the forwarded call is in progress.

NOTE: A single-line station cannot forward to an outside number. However, it can be forwarded to a keyset that is forward to an outside number. In this situation, it is possible that the caller will receive CO dial tone after the call reaches the forwarded keyset. The caller could then dial *any* outside telephone number, unaffected by any toll restrictions. Single-line stations should not forward calls to a keyset that is forwarded to an outside telephone number.

15.12 If the CO line is busy when the forward is attempted, an intercom caller hears a fast busy signal and an outside caller hears ringing.

15.13 Calls that are transferred to a station which is forwarded to the public network are affected by toll restriction only if the transferring station *and* the forwarded station are toll restricted and a restricted number is programmed as the forwarding destination. If either station is unrestricted, the call will be allowed. Direct ring-in calls will not forward to the public network if the forwarded station is toll restricted and has a restricted number programmed as the forwarding destination.

15.14 Outside-to-outside calls are limited by the Call Forward To The Public Network Duration timer. Before this timer expires, a warning tone is sent to the callers to alert them that the call will soon be disconnected. The Warning Signal timer determines when the signal will be heard and how long the callers will have before the call ends. Both timers can be programmed to allow sufficient time between the warning signal and the disconnection of the call. The transferring station user can avoid both timers by initiating a conference with the outside call and the forwarded keyset, and then allowing the call to continue as an unsupervised conference (refer to page 4-30). The call would then be affected only by the Unsupervised Conference timer (90 minutes) and the keyset would receive signal tones every two minutes.

NOTE: While this system is designed to be reasonably secure against CO line misuse by outside callers, there is no implied warranty that it is invulnerable to unauthorized intrusions. The GLX-Plus System does not have loop current detection capabilities. Therefore, disconnect supervision or any drop in loop current will not cause the GLX-Plus to drop the CO line connection. The GLX-Plus user must hang up when completing a call. If a call has been forwarded to the public network, the Forward to the Public Network timer will limit the duration of the call and disconnect the line when the timer expires.

Forwarding To Voice Mail

15.15 Station users can forward calls to a voice mail port. However, when outside calls are forwarded and connected to the voice mail system, the GLX-Plus System will not automatically dial the forwarding station's extension number to reach a personal mailbox. The outside caller will receive the initial system greeting from the voice mail and must dial the mailbox number of the person they are trying to reach.

15.16 If an intercom call follows the forward path and is connected to voice mail, the intercom caller must be using a GLX-Plus Keyset, single-line set, or a hand-held

DTMF generator to be able to use the voice mail features.

Using Call Forwarding

15.17 The receiving intercom or telephone number must be stored in station speed-dial location 1 at a keyset. If it is a telephone number, the speed-dial location code can be used for speed dialing and call forwarding. Single-line stations do not have speed-dial locations; however, an intercom number still must be stored as the forwarding destination.

15.18 If using an PBX line for call forwarding to the public network, enter the PBX line access code and a pause as part of the forwarding number. Then, when a call is forwarded, the system will wait after the PBX line access code, for the duration of the Pause Digit timer, before dialing the rest of the number.

15.19 Call forward requests are stored in battery-backed database memory and are not erased by a power failure or by unplugging the station. Station users can program call forward requests only when the KSU PRG EN switch is in the OFF position.

15.20 TO ENTER YOUR CALL FORWARD NUMBER:

Keysets

- (1) While on hook, press the SPDL key. The SPDL key flutters. The display shows: PROG SPDL.
- (2) Dial 1 for the speed-dial location.
- (3) Dial a two-digit intercom number or a telephone number with at least three digits. This is where forwarded calls will be sent. Use "10" for the attendant. **To include pauses in the number:** Press the SPDL key once for each pause. If more than 32 digits are entered, only the last 32 digits are retained.

NOTE: If you make a mistake, press a line key. The original number is retained.

- (4) Lift and replace the handset. You hear a confirmation tone and the SPDL key is unlit.

Single-Line Sets

- (1) Lift the handset and enter the Call Forward Program Destination feature code (*04).
- (2) Dial the desired intercom number (10-21).
- (3) Hang up.

15.21 TO TURN ON CALL FORWARDING:

NOTE: If you hear reorder tone when enabling call forwarding, it indicates that speed-dial location #1 does not contain a valid number.

Keysets

While on hook, enter the desired Call Forward feature code (#01 for no answer/busy or #02 for unconditional/direct ring-in). You see a medium-flashing SYS HOLD key and the display shows the forwarding condition that was enabled.

Single-Line Sets

Lift the handset and enter the Call Forward feature code (*01). After you hear the confirmation tone, hang up.

15.22 TO TURN OFF CALL FORWARDING:

Keysets

While on hook, enter either #01 or #02; either code will turn off both conditions. The SYS HOLD key is unlit.

Single-Line Sets

Lift the handset and enter the Cancel Call Forward feature code (*11). After you hear the confirmation tone, hang up.

16. PRIVACY RELEASE

16.1 The call privacy feature ensures the privacy of calls in progress by preventing users from selecting intercom channels or CO lines already in use. Users attempting to select a busy intercom channel or CO line hear a busy signal.

16.2 A keyset user may pick up and gain control of an outside call if it is ringing in, has been placed on system hold, or if it is recalling the system hold or individual hold. Single-line set users can reverse transfer ringing calls.

16.3 The database contains an option that allows the choice between having privacy on all lines, and having the ability to join on-going calls on busy lines. When the system is initialized, calls on all lines are private and any user attempting to select a busy line will hear busy tones. The conferencing feature must be used to include multiple parties on a single CO line.

16.4 When the privacy release feature is enabled, any keyset user may join an ongoing outside call by pressing the lit line key while on or off hook. Single-line set users can select the busy lines by lifting the handset and enter-

ing a CO Line Access feature code (91-96). Exceptions to this are established conference calls, data calls, calls on individual hold, and calls forced private by the user. If desired, as many as seven stations can participate in one call. When a station user hangs up, only that user is disconnected; all other parties remain connected.

17. CALL PRIVACY RESTORE (EXECUTIVE OR GLX-PLUS KEYSETS ONLY)

17.1 Even when privacy release is enabled system-wide, an individual Executive and GLX-Plus keyset user can restore call privacy during an outside call by entering the Privacy Enable feature code. The call then cannot be joined by other people unless the conferencing feature is used. If the call is transferred or placed on system hold, the privacy restore feature is canceled. Privacy is retained if the call is put on individual hold.

17.2 *TO RESTORE PRIVACY ON A NON-PRIVATE CO LINE:*

While on an outside call, press the SPCL key and enter the Privacy Enable feature code (8). The display shows: PRIVACY ENABLED.

18. CONFERENCE CALLS (KEYSETS ONLY)

18.1 Keypad users can establish a three- to five-party conference without operator assistance. A keypad user can initiate one conference at a time and the system can maintain two conference calls of up to five parties each. In addition to the initiating station, the conference can include any combination of up to four intercom and/or outside calls. The initiating station is considered one of the conferencing parties. Single-line station cannot establish conferences, but they can be included in conferences set up by keypad users.

NOTE: While this system is designed to be reasonably secure against CO line misuse by outside callers, there is no implied warranty that it is invulnerable to unauthorized intrusions. The GLX-Plus System does not have loop current detection capabilities. Therefore, disconnect supervision or any drop in loop current will not cause the GLX-Plus to drop the CO line connection. The GLX-Plus user must hang up when completing a call. If a call has been forwarded to the public network, the Forward to the Public Network timer will limit the duration of the call and disconnect the line when the timer expires.

18.2 If a conference is attempted when both conference circuits are busy, the initiating party hears a busy signal, inside parties are disconnected, and outside parties are put on individual hold. If an intercom call is attempted when all intercom channels are busy, the initiating party hears a busy signal and must hang up and wait for an available intercom channel before adding an intercom call to the conference.

18.3 While a conference call is in progress, the inside parties cannot dial numbers, enter hookflashes, or use the call transfer features.

18.4 Unlike the call privacy release option (page 4-29) where station users can join an ongoing call by lifting the handset and pressing a busy line key, conferences are private and station users attempting to join an ongoing conference call by pressing a busy line key will hear busy tones.

18.5 If the user who is initiating the conference wishes to enter an account code, it must be entered before the conference is established.

NOTE: Conferencing is not amplified on the GLX-Plus System. During a conference, some reduction in voice volume may be noticed, depending on CO line quality.

A. PLACING A CONFERENCE CALL

18.6 TO PLACE A CONFERENCE CALL:

- (1) While on an intercom or outside call, press the CNF key. The display shows: CNF SETUP. The party is placed on individual hold. If the call is to an outside party, the associated line key double flashes.
- (2) Place intercom or outside calls to (or pick up existing calls with) the other parties to be included in the conference and place them on conference hold by pressing the CNF key as described in the first step. If the call is to an outside party, the associated line key double flashes.

If connecting the fifth party, the conference is connected automatically when the CNF key is pressed to connect the fifth party. The display shows CNF IN PROGRESS on all display keysets involved in the conference, for the duration of the call.

If the conference is to consist of fewer than five parties: When all parties are on hold, press the CNF key again. All parties are connected. The associated DSS/BLF and line keys are lit. The display shows CNF IN PROGRESS on all display keysets involved in the conference, for the duration of the call.

B. EXITING A CONFERENCE

Creating An Unsupervised Conference

18.7 TO EXIT THE CONFERENCE AND LEAVE OTHER PARTIES CONNECTED IN AN UNSUPERVISED CONFERENCE (INITIATING KEYSSET ONLY):

Hang up. You hear a triple ring tone every two minutes and see the medium-flashing CNF key. To re-enter the conference, lift the handset and press the medium-flashing CNF key.

NOTE: If the conferenced parties hang up, the conference circuit remains busy until it is released by the initiating party. If the circuit is not released when the Unsupervised Conference timer expires (90 minutes), the circuit is dropped and any conferenced parties are disconnected.

Disconnecting All Conference Parties

18.8 TO END THE CONFERENCE AND RELEASE THE CONFERENCE CIRCUIT (INITIATING KEYSET ONLY):

During the conference, press the asterisk (*) key. All parties are disconnected and the conference circuit is dropped.

Placing The Conference Parties On Individual Hold

18.9 If a conference is terminated using the hold feature, the remaining outside callers hear music while they are waiting and all intercom calls are disconnected. The station user must return to the callers one at a time. If the Hold timer expires, the outside calls on hold recall the station that placed them on hold in the order they were

placed. If still unanswered after the Recall timer expires, they recall the station's attendant.

18.10 TO END THE CONFERENCE AND PLACE OUTSIDE PARTIES ON HOLD:

NOTE: Executive and GLX-Plus keyset users cannot use the HOLD key for this feature.

(1) During the conference, press the SYS HOLD key. The conference circuit and any inside parties are dropped, the outside parties are put on individual hold, and the line keys double flash.

(2) **To return to each party on hold:** Press the corresponding double-flashing line key.

To re-establish the conference: Refer to paragraph 18.6 on page 4-30.

19. SPEED DIALING (KEYSETS ONLY)

19.1 Speed dialing allows keyset users to store frequently dialed numbers. Two GLX-Plus features provide speed-dialing:

- **Station Speed Dialing:** Up to nine station speed-dial numbers can be stored by keyset users for their personal use.
- **System Speed Dialing:** Up to 30 system speed-dial numbers can be stored from the attendant's keyset, for use by any keyset user.

19.2 Both station and system speed-dial numbers are stored in the database, which is protected by the database back-up battery. In the event of a power failure, they will not be erased.

19.3 Speed-dial numbers can contain up to 32 digits, including pauses. For example, the number can contain an SCC local telephone number, a pause, the access code, a pause, and the desired telephone number. The duration of each pause is determined by the programmable Speed-dial Pause timer, which is preset at three seconds during initialization. Each pause is counted as one digit.

19.4 Speed-dial numbers are subject to toll restriction unless a system-wide option has been enabled that allows any station to dial any system speed-dial number regardless of that station's toll restriction.

A. STATION SPEED DIALING

19.5 Station speed-dial numbers are identified by a one-digit memory location code (1-9). Location code 1 is also used for the call forwarding feature (see page 4-27 for details).

19.6 TO STORE OR CHANGE STATION SPEED-DIAL NUMBERS:

NOTE: If you make a mistake while dialing the number, press any line key. If you press an invalid key or dial an invalid location code, you hear four fast tones and the keyset returns to the idle state. In either case, the original number is retained.

- (1) While on hook, press the SPDL key. The SPDL key flutters and the display shows PROG SPDL.
- (2) Dial the one-digit memory location code (1-9). The display shows the digit that was dialed.

- (3) Dial the telephone number (up to 32 digits, including pauses). The display shows the number as it is dialed. **To include pauses in the number:** Press the SPDL key once for each pause. If more than 32 digits are entered, only the last 32 digits are retained.

- (4) Lift and replace the handset. You hear a confirmation tone and the SPDL key is unlit.

19.7 TO DIAL STATION SPEED-DIAL NUMBERS:

- (1) Lift the handset and press an unlit line key.
- (2) Press the SPDL Key. The SPDL key lights. The display shows SPDL #:
- (3) Dial the one-digit memory location code (1-9). The number is dialed and the SPDL key is unlit. The display shows the number as it is dialed.

19.8 TO ERASE A STATION SPEED-DIAL NUMBER WITHOUT ENTERING A NEW NUMBER:

- (1) While on hook, press the SPDL key. The SPDL key flutters and the display shows PROG SPDL.
- (2) Dial the one-digit memory location code (1-9) to be erased.
- (3) Press the SPDL key again. (This enters a pause.)
- (4) Lift and replace the handset. You hear a confirmation tone and the SPDL key is unlit.

B. SYSTEM SPEED DIALING

19.9 System speed-dial numbers are identified by a three-digit memory location code (001-030).

19.10 System speed-dial numbers can only be stored or changed from the attendant's keyset. For system speed dial programming instructions, refer to the procedures on page 4-44.

19.11 TO DIAL SYSTEM SPEED-DIAL NUMBERS:

- (1) Lift the handset and press an unlit line key.
- (2) Press the SPDL key. The SPDL key lights.
- (3) Dial the three-digit memory location code (001-030). The display shows that location number as it is dialed. The number is dialed and the SPDL key is unlit. If you dial an invalid location code, you hear a busy signal and the CO line is placed on hold.

C. SPEED DIALING SPECIAL COMMON CARRIER (SCC) NUMBERS STORED IN SEPARATE LOCATIONS

19.12 A keyset user may chain speed-dial numbers together for dialing SCC services. SCC dialing requires the SCC local telephone number, your access code, and the long distance telephone number you want to dial. If desired, these numbers can be stored separately as station or system speed-dial numbers and can be dialed in the order needed.

19.13 TO SPEED DIAL SCC NUMBERS:

- (1) Lift the handset and press an unlit line key.
- (2) Press the SPDL key. The SPDL key lights.
- (3) Dial the memory location code (1-9 or 001-030) for the SCC local telephone number. The display shows the number as it is dialed and the SPDL key is unlit.
- (4) After the special dial tone, press the SPDL key. The SPDL key lights.
- (5) Dial the memory location code (1-9 or 001-030) for the SCC access code. The display shows the number as it is dialed and the SPDL key is unlit.
- (6) *If the telephone number is stored in a speed-dial location, press the SPDL key (the SPDL key lights) and dial the memory location code of the long distance number (1-9 or 001-030). The display shows the number as it is dialed and the SPDL key is unlit.*

If the telephone number is not stored in a speed-dial location, manually dial the long distance number if it is not stored in speed-dial memory.

20. DO-NOT-DISTURB (KEYSETS ONLY)

20.1 Placing a keyset in do-not-disturb halts all pages and all incoming intercom and transferred calls to that keyset. (Calls recalling from hold and direct ring-in calls are not blocked by do-not-disturb.) The keyset's DSS/BLF key flashes at the do-not-disturb rate on all Executive and GLX-Plus keysets. Another user calling the station while it is in do-not-disturb hears a repeating signal of four fast tones and a pause.

20.2 If your station is in do-not-disturb and you have call forwarding programmed, the calls will be forwarded as usual.

20.3 TO ENABLE OR DISABLE DO-NOT-DISTURB:

While on hook, dial #03. The display shows: DND TOGGLED. The SYS HOLD key lights while the keyset is in do-not-disturb and the display shows DO-NOT-DISTURB.

21. REDIALING (KEYSETS ONLY)

21.1 The redial feature stores the last telephone number dialed at the station (manually or speed-dialed numbers up to 32 digits). If the station user reaches a busy number or is disconnected, or if there is no answer, the number can be redialed easily. Only one telephone number can be stored in the battery-protected database memory at one time.

21.2 The programmable CO Delay timer inserts a delay between the time the SPDL and asterisk (*) keys or REDL key is pressed and the time the system redials the number. This delay ensures that the central office has restored dial tone before the number is dialed.

21.3 If any of the CO lines have the telephone company's Call Waiting feature enabled, the CO Delay timer may need to be adjusted to allow the Redial feature to be used.

21.4 TO REDIAL THE LAST NUMBER DIALED (STANDARD KEYSET):

- (1) **While still on the line:** When you reach an outside number that is busy or there is no answer, do not hang up.

When you are not on a line: Lift the handset and press an unlit line key.

- (2) Press the SPDL key. The SPDL key lights.
- (3) Press the asterisk (*) key on the keypad. The CO line is dropped and reseeded and the number is redialed. The SPDL key is unlit.

21.5 TO REDIAL THE LAST NUMBER DIALED (EXECUTIVE OR GLX-Plus KEYSET):

- (1) **While still on the line:** When you reach an outside number that is busy or there is no answer, do not hang up.

When you are not on a line: Lift the handset and press an unlit line key.

- (2) Press the REDL key. The REDL key lights. The CO line is dropped and reseeded and the number is redialed. The REDL key is unlit.

22. TIME AND DATE DISPLAY PROGRAMMING (GLX-PLUS KEYSSETS ONLY)

22.1 Each GLX-Plus keyset can have a customized time and date setting. The display appears in this format: HH:MM DAY MON XX. (For example: 12:25 TUE JAN 01.)

22.2 The user enters the following information when programming the display:

- **Time:** The time is entered with two digits for the hour and two digits for the minutes, in 24-hour clock format.
- **Date:** The date is entered by selecting the correct day of the week and the correct month, then entering the date.
- **Year:** Although the year is not displayed, it can be programmed so that the date is adjusted for leap years.
- **Toggle Time/Date Display:** The time and date display can be enabled or disabled as desired.
- **Toggle 12/24-Hour Clock:** The display can be set for 12- or 24-hour clock format.

22.3 The time and date must be set, at each keyset, when the keyset is first installed and then again after each initialization or power failure, or if the keyset is unplugged (unless optional keyset display battery back-up has been installed as described on page 3-30 in INSTALLATION). The keyset user can change the time/date setting as desired.

22.4 TO ENABLE/DISABLE THE TIME/DATE DISPLAY:

- (1) While on hook, press SPCL and enter the Program Time/Date feature code (4).
- (2) Enter the Toggle Time/Date Display feature code (4) to turn the display on or off. You hear a confirmation tone and the display shows: TIME DISPLAY ON/OFF.

22.5 TO SET THE TIME:

- (1) While on hook, press SPCL and enter the Program Time/Date feature code (4).

- (2) Enter the Program Time feature code (1). The display shows: TIME XX:XX.

- (3) Enter two digits for the hour (00-24) and then two digits for the minutes (00-59). Use 24-hour format. The Toggle 12/24-Hour Clock feature code will determine how the time appears on the display.

- (4) Lift and replace the handset. You hear a confirmation tone.

22.6 TO SET THE DATE:

- (1) While on hook, press SPCL and enter the Program Time/Date feature code (4).

- (2) Enter the Program Date feature code (2). The display shows: DATE DAY MON XX.

- (3) Press the asterisk (*) key until the correct day is displayed. Then press pound (#).

- (4) Press the asterisk (*) key until the correct month is displayed. Then press pound (#).

- (5) Press the asterisk (*) key until the correct date is displayed.

- (6) Lift and replace the handset. You hear a confirmation tone.

22.7 TO SET THE YEAR:

- (1) While on hook, press SPCL and enter the Program Time/Date feature code (4).

- (2) Enter the Program Year feature code (3). The display shows: YEAR: XXXX.

- (3) Enter four digits for the year (0000-9999).

- (4) Lift and replace the handset. You hear a confirmation tone.

22.8 TO SET THE CLOCK IN 12- Or 24-HOUR FORMAT:

- (1) While on hook, press SPCL and enter the Program Time/Date feature code (4).

- (2) Enter the Toggle 12/24-Hour Clock feature code (5). The clock mode is changed automatically and you hear a confirmation tone. The display shows: 12-HOUR CLOCK ON or 24-HOUR CLOCK ON.

23. SMDR DEVICE STATION

23.1 One Executive or GLX-Plus keyset can be designated as the SMDR device station. That keyset is then used for programming the SMDR parameters and generating the reports, using special SMDR feature codes. It can also be used for generating database reports.

23.2 SMDR station call data and/or database reports can be recorded on a customer-provided printer or an alternate device, such as a personal computer or floppy disk. This output device is connected to the optional GLX-Plus SMDR Adapter which is connected to the SMDR station's keyset.

A. STATION MESSAGE DETAIL RECORDING (SMDR)

23.3 Station message detail recording (SMDR) is a system feature that provides a detailed record of outgoing calls, outgoing toll calls (8 or more digits), and/or incoming calls. A sample of the SMDR report is shown in Figure 4-1 on page 4-37.

NOTE: SMDR programming and report printing can only be performed when the Program Enable switch is in the OFF position.

23.4 The SMDR parameters include the following:

- SMDR print conditions (SPCL 11)
- Time of day entry (SPCL 12)
- Date entry (SPCL 13)
- SMDR Valid Call timer (SPCL 14)
- Clock adjust, plus (SPCL 15)
- Clock adjust, minus (SPCL 16)

SMDR Print Conditions

23.5 Selectable SMDR print condition include the following. If no options are selected, all incoming and outgoing calls are selected.

- All incoming calls
- Outgoing calls — either all outgoing calls or only outgoing toll calls (8 or more digits)

23.6 *TO PROGRAM THE SMDR PRINT OPTIONS:*

- (1) While on hook, press SPCL and dial 1. The display shows SMDR OPTION.

- (2) Dial 1 again. The display shows SMDR PRT OPT.

- (3) Enter the number(s) of the option(s) you wish to enable (1-3). They appear on the display when entered.

- (4) Lift and replace the handset. You hear a confirmation tone.

- (5) *If you wish to program additional SMDR parameters, follow the instructions for the desired parameter, but skip step 1.*

If you wish to exit from SMDR programming and print a report, lift and replace the handset again. You hear a confirmation tone and the SMDR printout is generated.

Time of Day

23.7 The time of day should be set before generating the first SMDR report and after every system initialization. If it is not, "***:**" appears in place of the time and "***-**-***" appears in place of the date. (This programming is not related to the keyset display time and must be performed separately.)

23.8 The time is entered in 24-hour format (00:00 is midnight, 12:00 is noon). If an invalid time entry is made, you will hear a burst of reorder tone and the time will remain unchanged. Occasionally, the time may appear with a question mark (?) following it. That means that the time information may be incorrect due to a power failure or other system problem. To clear the question mark, the time must be reprogrammed.

23.9 *TO SET THE TIME OF DAY:*

- (1) While on hook, press SPCL and dial 1. The display shows SMDR OPTION.

- (2) Dial 2. The display shows SMDR TIME.

- (3) Enter four digits for the current time. (Or, hook-flash to disable the time of day and date.) The display shows the time as it is entered. The first two digits represent the hour (00-23) and the second two digits represent the minutes (00-59).

- (4) Lift and replace the handset. You hear a confirmation tone.

- (5) *If you wish to program additional SMDR parameters, follow the instructions for the desired parameter, but skip step 1.*

If you wish to exit from SMDR programming and print a report, lift and replace the handset again. You hear a confirmation tone and the SMDR printout is generated.

Date

23.10 The current date should be set before generating the first SMDR report and after every system initialization. If it is not, "***-**-***" appears in place of the date.

23.11 If you enter a valid time-of-day entry without a date, the date will appear as "01-01-01." Occasionally, the date may appear with a question mark (?) following it. That means that the current date information may be incorrect due to a power failure or other system problem. To clear the question mark, the date must be reprogrammed.

23.12 TO SET THE DATE:

- (1) While on hook, press SPCL and dial 1. The display shows SMDR OPTION.
- (2) Dial 3 and then lift and replace the handset. You hear a confirmation tone. The display shows SMDR DATE.
- (3) Enter six digits for the date. (Or, hookflash to disable the date function.) The display shows the date as it is entered. The first two digits are the month (01-12), the next two are the date (01-31), and the final two are for the year (00-99).
- (4) *If you wish to program additional SMDR parameters, follow the instructions for the desired parameter, but skip step 1.*

If you wish to exit from SMDR programming and print a report, lift and replace the handset again. You hear a confirmation tone and the SMDR printout is generated.

SMDR Valid Call Timer

23.13 The Valid Call timer determines when a call will be included in the SMDR output. The value of the timer can be 0-59 seconds. If it is set to 0-seconds, all outgoing calls that meet the SMDR print option requirements will be recorded.

23.14 An outgoing call that meets the print option requirements and lasts longer than the programmed Valid Call timer is recorded; however, if the call was transferred to a station or placed on hold, the Valid Call timer is not checked and the call is recorded.

23.15 The Valid Call timer does not affect incoming calls; if the option to record incoming calls is selected in the database, all incoming calls are listed.

23.16 TO SET THE VALID CALL TIMER:

- (1) While on hook, press SPCL and dial 1. The display shows SMDR OPTION.
- (2) Dial 4 and then lift and replace the handset. You hear a confirmation tone. The display shows VALID CALL.
- (3) Enter the valid call time in seconds (0-59). It appears on the display when entered.
- (4) *If you wish to program additional SMDR parameters, follow the instructions for the desired parameter.*

If you wish to exit from SMDR programming and print a report, lift and replace the handset again. You hear a confirmation tone and the SMDR printout is generated.

Clock Adjust

23.17 If the SMDR clock appears to be running too fast or too slow, an adjustment can be set using one of these options. The amount of time indicated is added to or subtracted from the SMDR clock each time it reaches midnight. (This is a *daily* adjustment, not a *one-time* adjustment.) The time can be adjusted plus or minus 0-15 seconds each day.

23.18 TO ADJUST THE SMDR CLOCK:

- (1) While on hook, press SPCL and dial 1. The display shows SMDR OPTION.
- (2) *If you need to add seconds to the clock:* While on hook, dial 5.

If you need to subtract seconds from the clock: While on hook, dial 6.
- (3) Lift and replace the handset. You hear a confirmation tone. The display shows CLK ADJ + or CLK ADJ -.
- (4) Enter the amount of time in seconds (0-15) that the clock should be adjusted. The time appears on the display when entered.
- (5) *If you wish to program additional SMDR parameters, follow the instructions for the desired parameter, but skip step 1.*

If you wish to exit from SMDR programming and print a report, lift and replace the handset again. You hear a confirmation tone and the SMDR printout is generated.

FIGURE 4-1. SMDR REPORT FORMAT

SMDR REPORT:

```
----- top of page -----  
Inter-Tel GLX-12  
Station Message Detail Recording (SMDR)  
MM-DD-YY  
STN          NUMBER DIALED          TIME   DUR   LN  ACCOUNT  
XX  XXXXXXXXXXXXXXXXXXXXXXXXXXXX  HH:MM HH:MM  X  XXXXXXXX  
----- end of report -----
```

Explanation Of Abbreviations:

- STN** The intercom number (10-21) of the last station to handle the call.

- NUMBER DIALED** Up to 32 digits of the telephone number dialed. Pauses in the number will appear as "P."

- LN** The CO line number used (1-6).

- TIME** The time of day that the call was placed, in 24-hour format.

- DUR** Call length from the beginning of the call until disconnect. Elapsed time is rounded up to the nearest minute to show hours and minutes.

- ACCOUNT** If an optional account code is associated with this call, it appears in this field. The field is blank if no account code was used.

B. DATABASE REPORTS

23.19 A database report can be generated at the SMDR device station and printed to show a summary of database programming. The reports are useful tools for troubleshooting as well as for record keeping.

23.20 Database reports can be generated for the following system programming areas:

- **SMDR Set-Up:** Includes all SMDR parameter programming.
- **System Report:** Includes all system programming information, except speed-dial numbers.
- **Station Report:** Includes all station information for each of the 12 stations, except for speed-dial numbers.
- **Speed-Dial Report:** Includes all system and station speed-dial numbers.
- **Programming Report:** Includes all of the above information in one report.

23.21 If SMDR is enabled when the database report is requested, the SMDR information is held in a buffer

while the database report is printed. (The buffer can hold up to 16 SMDR records.) A form feed command is sent before and after the database report so that it can be easily separated from the SMDR report.

23.22 While the report is being generated, the attached keyset will not be available for placing or receiving calls or using other features.

23.23 The Program Enable switch on the KSU can be in the ON or OFF position when database reports are generated.

23.24 TO GENERATE A DATABASE REPORT:

- (1) While on hook, press SPCL and enter 3. The display shows SMDR D/R REPORT.
- (2) Enter the number of the desired report. The selection is identified on the keyset display.
0 = SMDR Set-Up
1 = System Report
2 = Station Report
3 = Speed-Dial Report
4 = Program Report
- (3) Lift and replace the handset. You hear a confirmation tone and the report is sent to the printer.

FIGURE 4-2. DATABASE REPORT FORMAT

SMDR PRINT CONDITIONS REPORT:

----- top of page -----
Inter-Tel GLX-12
Database Report - SMDR Set-Up Parameters
SMDR Set-up:
SMDR Print Conditions SPCL 1 1: X,X
Current Time-of-Day SPCL 1 2: HH:MM
Current Date SPCL 1 3: MM-DD-YY
SMDR Valid Call Time SPCL 1 4: XX Sec.
Clock Adjust, Plus SPCL 1 5: +XX Seconds/Day
Clock Adjust, Minus SPCL 1 6: -XX Seconds/Day
----- end of report -----

FIGURE 4-2. DATABASE REPORT FORMAT (Continued)

SYSTEM FEATURES REPORT:

----- top of page -----

Inter-Tel GLX-12

Database Report - System Features

System Timers:

Attendant Recall	* 1 1	XXX Sec.
Hold Recall	* 1 2	XXX Sec.
Inactivity	* 1 3	XX Sec.
Call Forward Duration	* 1 4	XXX Sec.
Call Forward Warning	* 1 5	XXX Sec.
Call Forward No Answer	* 1 6	XX Sec.

Feature Timers:

C.O. Flash	* 2 1	X.X Sec.
C.O. Delay	* 2 2	X.X Sec.
Speed-Dial Pause	* 2 4	X.X Sec.
Memory-Dial Speed	* 2 5	X.X Sec.
C.O. Ring Duration	* 2 7	X.X Sec.
Abandoned Call	* 2 8	XX.X Sec.

Miscellaneous Timers:

Make/Break Ratio	* 3 1	XX %
Pulse-Dial Speed	* 3 2	0.X Sec.
Pulse-Dial Interdigit	* 3 3	0.X Sec.

Lines Not Subject to

Toll Restriction #4: X,X,X,X,X,X

System Options

#5: X,X,X,X,X,X,X,X

Call Forward to Public

Network Line #6: X

Call Forward,

DIL Diversion Lines #7: X,X,X,X,X,X

Pulse-Dialing Lines

#8: X,X,X,X,X,X

Night Security Code

#9: XXXX

----- end of report -----

FIGURE 4-2. DATABASE REPORT FORMAT (Continued)

STATION FEATURES REPORT:

----- top of page -----
Inter-Tel GLX-12
Database Report - Station Features

Station 10					
Restricted Lines	# 1:	X,X,X,X,X,X			
Ring-In Lines	# 2:	X,X,X,X,X,X			
Options	# 3:	X,X,X,X,X,X,X,X			
. . .					
Station 21					
Restricted Lines	# 1:	X,X,X,X,X,X			
Ring-In Lines	# 2:	X,X,X,X,X,X			
Options	# 3:	X,X,X,X,X,X,X,X			

----- end of report -----

FIGURE 4-2. DATABASE REPORT FORMAT (Continued)

SPEED-DIAL NUMBERS REPORT:

----- top of page -----

Inter-Tel GLX-12

Database Report - Speed-Dial Numbers

Station Speed-Dial Numbers

Station 10

- 1 = All digits in speed-dial location appear, pauses are shown as P
- 2 =
- 3 =
- 4 =
- 5 =
- 6 =
- 7 =
- 8 =
- 9 =

. . .

Station 21

- 1 =
- 2 =
- 3 =
- 4 =
- 5 =
- 6 =
- 7 =
- 8 =
- 9 =

System Speed-Dial Numbers

- 001 = All digits in speed-dial location appear, pauses are shown as P
- 002 =
- 003 =
- 004 =
- 005 =
- 006 =
- 007 =
- 009 =
- 010 =
- . . .
- 025 =
- 026 =
- 027 =
- 028 =
- 029 =
- 030 =

----- end of report -----

24. SYSTEM ATTENDANT STATION

24.1 The system has one attendant. Intercom number 10 is assigned to the system attendant's keyset. The attendant station provides the following services:

- Can be called by dialing "0"
- Central operator for incoming calls
- Recall station for unanswered calls
- Places the system in night mode or day mode
- Programs the night security code
- Programs system speed-dial numbers
- Programs all system features

A. ATTENDANT RECALL

24.2 When a call is placed on hold or is transferred from one station to another, certain system timers limit the amount of time the call may remain unattended. After that time, the call recalls the station to which it was transferred or the station that placed it on hold. If the call remains unanswered at the station until the Attendant Recall timer expires, it recalls the attendant. If the attendant station is busy, the call camps on and the display shows the source of the recall. If the call is not answered before the Attendant's Abandoned Call timer expires (10 minutes), the system disconnects the call.

24.3 A recall signals rings at the attendant's station like a direct ring-in call and the display shows INCOMING CALL. If the attendant has calls forwarded, recalls from stations do not follow call forward requests. Placing the attendant's station in do-not-disturb does not block recalls or direct ring-in calls.

24.4 TO ANSWER AN ATTENDANT RECALL:

Lift the handset (or press the ON/OFF key) and press the fluttering line key.

B. PLACING THE SYSTEM IN NIGHT MODE

24.5 CO lines that ring in at the attendant's keyset can be programmed to ring in at one or more alternate key-

sets when the system is placed in night ring mode. Refer to page 5-12 for programming information. CO lines that are not programmed to ring in at the attendant's keyset are not affected by night ring mode and continue to ring in as programmed. Attendant recalls continue to ring at the attendant's keyset when the system is in night ring mode.

24.6 TO PLACE THE SYSTEM IN NIGHT RING MODE:

- (1) Lift the handset and press the SYS HOLD key.
- (2) Press the asterisk (*) key on the keypad. The display shows: NIGHT MODE TOGLD. You hear intercom dial tone and the SYS HOLD key flashes slowly.
- (3) Hang up.

24.7 TO CANCEL NIGHT RING MODE:

Lift the handset, press the slow-flashing SYS HOLD key, and hang up. The SYS HOLD key is unlit.

C. NIGHT SECURITY CODE

24.8 The system can be programmed to require a night security code when placing toll calls by entering option 5 while programming system options. Or, it can be programmed to require a night security code when placing any outside call by entering both option 5 and option 7 while programming system options.

24.9 When the system is initialized, the security code is 9999. The attendant's station can be used to reprogram the code. Any combination of digits, asterisks (*), and pounds (#) can be used as part of the code, but *, #, 0, 1, 2, or 8 cannot be used as the first digit.

24.10 TO PROGRAM THE SECURITY CODE:

- (1) While on hook, press #. The display shows PROGRAM FEATURES.
- (2) Dial 9. The display shows SEC CODE.
- (3) Dial the desired four-digit security code. The display shows the code as it is entered.
- (4) Lift and replace the handset.

D. PROGRAMMING SYSTEM SPEED-DIAL NUMBERS

24.11 TO STORE OR CHANGE SYSTEM SPEED-DIAL NUMBERS:

NOTE: If you make a mistake while dialing the number, press any line key. If you press an invalid key or dial an invalid location code, you hear four fast tones and the keyset returns to the idle state. In either case, the original number is retained.

- (1) While on hook, press the SPDL key. The SPDL key flutters and the display shows PROG SPDL.
- (2) Dial the three-digit memory location code (001-030). The display shows the digits as they are dialed.
- (3) Dial the telephone number (up to 32 digits, including pauses). The display shows the number as it is dialed. To include pauses in the number, press the SPDL key once for each pause. If more

then 32 digits are entered, only the last 32 digits are retained.

- (4) Lift and replace the handset. You hear a confirmation tone and the SPDL key is unlit.

24.12 TO ERASE A SYSTEM SPEED-DIAL NUMBER WITHOUT ENTERING A NEW NUMBER:

NOTE: System speed-dial numbers can only be erased using the attendant's keyset (intercom number 10).

- (1) While on hook, press the SPDL key. The SPDL key flutters and the display shows PROG SPDL.
- (2) Dial the three-digit memory location code (001-030). The display shows the digits as they are dialed.
- (3) Press the SPDL key again. (This enters a pause.)
- (4) Lift and replace the handset. You hear a confirmation tone and the SPDL key is unlit.

PROGRAMMING

<i>CONTENTS</i>	<i>PAGE</i>
1. Introduction	5-1
2. Program Planning Sheets	5-1
3. Outline For Programming New Systems	5-1
4. Initialize The System	5-6
A. KSU Initialization	5-6
B. APM Initialization	5-6
C. Initializing The KSU And APM	5-7
5. Program The System And Station Features	5-8
A. KSU Database Programming	5-8
B. Station Features Programming	5-12
C. APM Database Programming	5-14

1. INTRODUCTION

1.1 This section describes the initialization and programming procedures for the GLX-Plus System. For proper operation, the system must be initialized when it is installed. Programming allows the system and station features to be customized to meet each user's needs.

2. PROGRAM PLANNING SHEETS

2.1 Programming is easier, quicker, and more accurate when it is planned in advance. Refer to the program planning sheets on the next four pages. Make copies of the program planning sheets and fill in the blanks as you read through this section. When the sheets are completed, you will have all the necessary information to program the system. Save copies of the sheets at the system site and in the installer's records for future reference.

3. OUTLINE FOR PROGRAMMING NEW SYSTEMS

3.1 Program a newly installed system as follows:

- (1) Place the KSU PWR and PRG EN switches in the ON position.
- (2) Initialize the system as described on page 5-6.
- (3) Program the system and station features as described in this chapter.
- (4) Place the PRG EN switch in the OFF position when programming is completed.

NOTE: It is important to return the PRG EN switch to the OFF position when finished. If the switch is left in the ON position, users could inadvertently change programming while using their stations. Also, the on/off feature codes for headsets, background music, call forwarding, and do-not-disturb cannot be used when the PRG EN switch is in the ON position.

FIGURE 5-1. PROGRAM PLANNING SHEETS

SYSTEM FEATURES

Performed from the attendant's keyset (intercom number 10).

SYSTEM TIMERS: Enter numbers in seconds. If the timer is not desired, enter 0.

TIMER	CODE	DESIRED VALUE	DEFAULT	RANGE
Attendant Recall	* 1 1	_____	180 seconds	0, 60-600 seconds
Hold Recall	* 1 2	_____	60 seconds	0, 15-300 seconds
Inactivity	* 1 3	_____	15 seconds	0, 15-60 seconds
Call Fwd to PN Dur.	* 1 4	_____	150 seconds	30-900 seconds
Call Fwd to PN Warn	* 1 5	_____	30 seconds	0-150 seconds
Call Fwd No Answer	* 1 6	_____	15 seconds	3-60 seconds
Make/break Ratio	* 3 1	_____	9 (64%)	14%-86% break
Pulse-dial Speed	* 3 2	_____	0.1 seconds	0.1-0.2 seconds
Pulse Interdigit	* 3 3	_____	0.8 seconds	0.6-1.0 seconds

FEATURE TIMERS: Enter numbers in tenths of a second (2 = 0.2 second, 20 = 2.0 seconds, etc).

TIMER	CODE	DESIRED VALUE	DEFAULT	RANGE
C.O. Flash	* 2 1	_____	0.7 second	0.2-1.2 seconds
C.O. Delay	* 2 2	_____	2.5 seconds	0.1-5.0 seconds
Speed-Dial Pause	* 2 4	_____	3.0 seconds	1.0-5.0 seconds
Memory-dial Speed	* 2 5	_____	0.1 second	0.1 or 0.2 second
C.O. Ring Duration	* 2 7	_____	0.4 second	0.2-2.0 seconds
Abandoned Call	* 2 8	_____	6.0 seconds	4.0-20.0 seconds

EXCLUDE C.O. LINE FROM TOLL RESTRICTION: Enter desired line key number(s). No line is preset when the system is initialized.

CODE	DESIRED LINE(S)
# 4	_____

FIGURE 5-1. PROGRAM PLANNING SHEETS (Continued)

SYSTEM OPTIONS: Enter desired option numbers. When the system is initialized, option 1 is preset.

<u>CODE</u>	<u>DESIRED OPTIONS</u>
# 5	_____

Options are as follows:

Choose one:

- 1 — Restrict calls beginning with 0 or 1.
- 2 — Restrict calls beginning with 0 or 1 or >8 digits long.
- 3 — Restrict calls beginning with 0 or 1 or >8 digits long, but allow 1411, 1911, 1-555-XXXX, 1-XXX-555-XXXX, 800-XXX-XXXX, and 1-800-XXX-XXXX.

Use as needed:

- 4 — Allow system speed-dial numbers to bypass toll restriction.
- 5 — Require night security code to dial toll calls.
- 6 — Enable call privacy release.
- 7 — Require night security code to dial any calls.

CALL FORWARD LINES: Enter desired line key number(s). No line is preset when the system is initialized.

<u>CODE</u>	<u>DESIRED LINE(S)</u>
# 6 (Call Forward to Public Network Line)	_____
# 7 (DIL Diversion Lines)	_____

DIAL-PULSE LINE(S): Enter desired line key number(s). No line is preset when the system is initialized.

<u>CODE</u>	<u>DESIRED LINE(S)</u>
# 8	_____

NIGHT SECURITY CODE: Enter the desired night security code. Initialized value is 9999.

<u>CODE</u>	<u>DESIRED SECURITY CODE</u>
# 9	_____

FIGURE 5-1. PROGRAM PLANNING SHEETS (Continued)

STATION FEATURES

Performed at individual stations. (Place check marks in the appropriate boxes.)

STATION INTERCOM NUMBER	#1 RESTRICTED LINES						#2 RING-IN LINES						#3 STATION OPTIONS*								#9 ALL LINES RESTR.			
	1	2	3	4	5	6	1	2	3	4	5	6	1	2	3	4	6	8						
10																								
11																								
12																								
13																								
14																								
15																								
16																								
17																								
18																								
19																								
20																								
21																								
APM 1																								
APM 2																								

NOT APPLICABLE ON KEYSETS

*Station options are as follows:

- 1 — Incoming Page Disable
- 2 — Ring Intercom First
- 3 — Night Answer
- 4 — Speakerphone Activation Pre-select Disable
- 6 — Toll Restrict
- 8 — Ringing Line Preference — Automatic Access

FIGURE 5-1. PROGRAM PLANNING SHEETS (Continued)

APM FEATURES

Performed at individual single-line stations using an industry-standard 2500 set.
Each feature programming code is preceded by *09 (APM Database Programming Mode).

FEATURE	APM PORT #1	APM PORT #2
Call Waiting Tones (#10 no/#20 yes)		
Intercom Ring Cadence (#11 extended/#21 standard)		
Single-Line Minimum Hookflash Timer (#15 and range 01-10)		
Single-Line Maximum Hookflash Timer (#16 and range 02-20)		
Single-Line Port dB Padding (#13 no/#23 yes)		

4. INITIALIZE THE SYSTEM

4.1 The KSU and APM must be initialized when it is first installed and may require a reset or initialization if a database error occurs (refer to TROUBLESHOOTING). The KSU and APM are initialized using separate procedures, as described below.

A. KSU INITIALIZATION

4.2 The KSU contains the system software. The system features are initialized with the following default values. Each feature is described in this section or in the FEATURES section of the manual.

- The attendant's intercom number is 10. (This is not programmable.)
- Only the attendant's station rings for incoming calls; however, the corresponding line keys flash on all keysets for incoming calls.
- The timers are set as follows. Programmable timers are marked with an asterisk.
 - * Abandoned Call timer: 6 seconds
 - * Attendant Recall timer: 180 seconds
 - Attendant's Abandoned Call timer: 10 minutes
 - * Call Forward To The Public Network timer: 150 seconds
 - * Call Forward To The Public Network Warning timer: 30 seconds
 - * Call Forward No Answer timer: 15 seconds
 - * CO Delay timer: 2.5 seconds
 - * CO Flash timer: 0.7 seconds
 - * CO Ring Duration timer: 0.4 seconds
 - * Hold Recall timer: 60 seconds
 - * Inactivity timer: 15 seconds
 - * Make/break Ratio: 9 (64% break)
 - * Memory-dial Speed timer: 0.1 second
 - * Pulse-dial Speed timer: 0.1 seconds
 - * Pulse Interdigit timer: 0.8 seconds

- * Speed-dial Pause timer: 3 seconds
- Unsupervised Conference Release timer: 90 minutes
- System option 1 is enabled.
- All CO lines are subject to toll restriction.
- A call forward CO line is not preset.
- All keysets can access all CO lines for outgoing calls.
- No station options are preset.
- System speed-dial numbers are erased. Station speed-dial numbers (if any) are not erased.
- Ringing line preference is disabled.
- Security code is disabled and set to 9999.

B. APM INITIALIZATION

4.3 The APM software has single-line specific features that relate only to the single-line ports on the APM. Programming for these single-line port features is stored in the APM memory instead of the GLX-Plus System memory. The KSU system programming switch does not affect the APM database programming, therefore, the position of the switch (off or on) will not interfere with any APM Database programming. However, any station options and features that are normally part of the KSU database programming are still programmed in the KSU database for the single-line stations (intercom numbers 20 and 21).

4.4 The APM software database **MUST** be initialized using the APM Initialization feature code. The APM initialization will have no effect on the system software or any keyset operation (including the two keyset ports on the APM module). APM initialization affects only the two single-line ports on the APM.

4.5 The following parameters are set when the APM database is initialized:

- Call Waiting Tones — Allowed
- Intercom Ring Cadence — Standard
- Single-line Minimum Hookflash — 200ms
- Single-line Maximum Hookflash — 700ms
- CO dB Padding — Disabled

C. INITIALIZING THE KSU AND APM

CAUTION

The initialization function returns the database to default values.

KSU Initialization

4.6 The following steps give the procedures for initializing the KSU. These steps **MUST** be performed before further KSU programming is started. If an APM is installed, the APM software database and single-line ports also must be initialized as described below.

4.7 TO INITIALIZE THE KSU:

- (1) Ensure that the KSU PRG EN switch is in the ON position.
- (2) **Initialize the KSU:** From the attendant's station (intercom number 10): While on hook, dial # 0 1 2. The GLX-Plus keyset display shows INITIALIZING DB. You hear a confirmation tone when the system initialization is completed.
- (3) *If an APM is installed*, initialize the APM software database and APM ports as described below.
- (4) *If no other programming is necessary*, place the PRG EN switch in the OFF position.

APM Software Database and APM Port Initialization

4.8 The following steps give the procedures for initializing the APM software database and the APM single-line ports. If an APM is installed, these steps **MUST** be performed before further KSU or APM programming is started. Also, **BOTH** APM single-line ports must be initialized, *even if only one port or neither port will be used*.

- (1) Ensure that the KSU PRG EN switch is in the ON position.

- (2) **Initialize the APM software database:** This procedure can be performed using either APM single-line port.

- a. *At either single-line port*, lift the handset and dial * 0 9 (APM Database Programming Mode).
- b. Dial # 1 9 (APM Database Initialization). You will hear a confirmation tone followed by intercom dial tone.
- c. Hang up.
- d. Place a call into the GLX-Plus System (from an outside telephone or using a GLX-Plus station and a CO line) and allow it to ring for two ring cycles. This procedure is necessary to allow the APM to synchronize flash rates for the single-line ports. **Failure to perform this step will cause erroneous APM port operation.**

- (3) **Initialize the APM single-line ports:**

- a. At the single-line set that is connected to APM port 1, lift the handset.
- b. When you hear dial tone, dial # 3 and hang up until the DSS key for APM port 1 is unlit (approximately 15 seconds). This sets the station options to default values.
- c. After one minute, lift the handset again.
- d. Hang up.
- e. Repeat this procedure using the single-line set connected to APM port 2.

NOTE: You must initialize **BOTH** APM single-line ports for proper APM operation, *even if only one port or neither port will be used*.

- (4) *If no other programming is necessary*, place the PRG EN switch in the OFF position.

5. PROGRAM THE SYSTEM AND STATION FEATURES

5.1 Some general programming procedures include the following:

- At keysets, programming is performed using the keypad and line keys while the handset is on hook. At single-line stations, programming is performed off hook after dial tone is received.
- At keyset stations, lifting and replacing the handset stores the programmed information and completes the programming sequence. At single-line stations, hanging up and waiting until the associated DSS/BLF key (on a keyset station) goes out completes the programming sequence.
- At a keyset, you will hear a confirmation tone every time you lift and replace the handset if you have completed a valid programming sequence. At a single-line station, you must wait for the associated DSS/BLF key to go out.
- If you make a mistake, lift and replace the handset and start over.
- If you enter invalid information at a station, you will hear four short ring tones. If using a single-line set, hang up and wait for the DSS/BLF key for that station to be unlit before repeating the programming procedure. If using a keyset, the station returns to idle state and you can simply re-enter the programming code and the correct information; then lift and replace the handset.
- When programming system or station information (including single-line station programming) that is stored in the KSU, the KSU PRG EN switch must be in the ON position.
- When programming APM database, the position of the KSU PRG EN switch does not affect programming. It can be in the ON or OFF position.

A. KSU DATABASE PROGRAMMING

5.2 The following system features can be programmed using the attendant's keyset. For further explanations of the timers and features, refer to the FEATURES section. Programming procedures are explained beginning on page 5-10.

- **Attendant recall timer:** A call recalling from hold will ring at the station where the call was placed on hold until this timer expires; it then recalls the atten-

tant. The timer is preset to 180 seconds during initialization. If this feature is not desired, enter 0 for the timer value.

- **Hold recall timer:** When a call is placed on hold, it does not signal the station until this timer expires. Then, it recalls the station where it was placed on hold and rings until the attendant recall timer expires. The timer is preset to 60 seconds during initialization. If the timer is not desired, enter 0 for the timer value.
- **Inactivity timer:** This limits the amount of time a station can remain off hook and inactive before the system locks it out. The user must then press and release the hookswitch before using the station again. The timer is preset to 15 seconds during initialization. If the timer is not desired, enter 0 for the timer value.
- **Call forward to the public network timer:** The duration of a direct ring-in call or transferred outside call that is forwarded to the public network is limited by this timer (that is, the call is disconnected when the timer expires). Because the system does not detect loop current or disconnection signals on this type of call, this timer is needed to disconnect the line and make it available to other users after the outside parties have ended their conversation. The timer is preset to 150 seconds during initialization.
- **Call forward to the public network warning timer:** Before the timer described above expires, both outside parties will hear a warning tone that signals the end of the calling period. This timer determines when the warning signal is given. It can be adjusted to allow more or less time between the warning signal and the disconnection of the call. When the system is initialized, this timer is preset to send the warning signal 30 seconds before the end of the call.
- **Call forward no answer timer:** There is a call forwarding option that allows the user to forward calls only when the station is busy or there is no answer. If the station is busy, an incoming call is forwarded immediately. If there is no answer, the call is forwarded when this timer expires. This timer is preset to 15 seconds during initialization.
- **CO flash timer:** This is the duration of the hookflash generated when a line key or the FLASH key is pressed. A timed hookflash is used to disconnect calls without hanging up; it also allows users to access PBX or telephone company features. The timer is preset to 0.7 seconds during initialization.

- **CO delay timer:** When a station user wishes to redial a telephone number while still on the line, this timer inserts a delay between the time the user presses the SPDL and * keys or the REDL key and the time the system dials the number. The delay ensures that the central office has restored dial tone before the number is dialed. The timer is preset to 2.5 seconds during initialization.
 - **Speed-dial pause timer:** When a series of telephone numbers or codes is entered in one speed-dial location (for example, an SCC access number, an account code number, and a telephone number), a pause can be entered between the numbers to allow time for each number or code to be processed. When a pause is entered in a speed-dial location, this timer is the length of the pause. It is preset to 3 seconds during initialization.
 - **Memory-dial speed timer:** Some central offices and PBX systems cannot process speed-dialed and redialed numbers as quickly as the GLX-Plus System sends them (0.1 seconds per digit). This timer slows the dialing speed to 0.2 seconds per digit. The length of the DTMF tone is not affected; only the duration of the pause between digits is changed. The timer is preset to 0.1 second during initialization.
 - **CO ring duration timer:** When the system detects an incoming ring signal, it causes the programmed ring signals that are equal to or longer than this timer. This prevents CO line noise from causing false ring-in. The timer is preset to 0.4 second during initialization.
 - **Abandoned call timer:** This is the time that an unanswered incoming CO call will continue to ring in to the system after the central office stops sending ring signal. The timer is preset to 6 seconds during initialization.
 - **Make/breakratio timer:** When a C.O. line is designated for dial-pulse signaling, the system provides a specific make and break time for each pulse. When the system is initialized, this timer is preset to 64% break, which represents 64% of the pulse-dial speed. If the pulse-dial speed timer (below) is set to 0.1 seconds, this is 64 msec. If the pulse-dial speed is 0.2, this is 128 msec. Refer to page 5-11 for a table showing the values.
 - **Pulse-dial speed timer:** The speed at which the pulses are sent is determined by this timer. If the pulse-dial speed is set at 0.2, the make/break times are doubled, as described above. When the system is initialized, this timer is preset to 0.1 seconds.
 - **Pulse-dial interdigit timer:** This timer controls the length of the pause between digits. The interval between pulse-dialed digits can be increased or decreased to meet the specifications of the central office. (This does not affect the pulse speed; dialing speed is controlled by the pulse-dial speed timer.) When the system is initialized, this timer is preset to 0.8 seconds.
 - **Exclude CO line from toll restriction:** If a CO line is excluded from toll restriction, toll restricted station users can access the CO line for placing calls that would normally be denied. No CO lines are pre-set during initialization.
 - **System options:** System option 1 is preset during initialization. The first four of the following options apply only to stations enabled with Station option 6 (toll restrict).
- NOTE:** If more than one of the first three options (1-3) below are enabled, the system will compare the number dialed to only the lowest-numbered option.
- **Option 1 — Restrict calls with 0 or 1 as first digit:** Prevents toll calls from being made if the first digit dialed is a 0 or 1.
 - **Option 2 — Restrict calls with 0 or 1 as first digit, or more than eight digits long:** Prevents toll calls from being made if the first digit dialed is a 0 or 1, or if the number is more than eight digits long.
 - **Option 3 — Restrict calls with 0 or 1 as first digit, or more than eight digits long, but allow 1411, 1911, and numbers that begin with 1-555, 1-XXX-555, 800, and 1-800:** Prevents toll calls from being made if the first digit dialed is a 0 or 1, or if the number is more than eight digits long. But it allows directory assistance, emergency, and toll-free numbers to be dialed.
 - **Option 4 — Allow system speed-dial numbers to bypass toll restriction:** Permits system speed-dial numbers to bypass the toll restrictions enabled by option 1, 2, or 3. Because option 4 modifies the other options, it is never used by itself.
 - **Option 5 — Night mode toll call security code:** Users must enter a night security code to place toll calls while the system is in night mode. When this option is enabled, all stations are changed to toll class 3 (all toll calls are restricted) whenever the system is placed in night mode. Entering the four-digit night security

code returns the station to its normal toll restriction status.

- **Option 6 — Privacy release:** With privacy release enabled, users can directly access busy lines to join on-going outside calls. If desired, all keyset users can join one outside call. When a station user hangs up, only that user is disconnected and any other parties remain connected. Multi-party calls cannot be placed on hold or transferred.
- **Option 7 — Night mode all calls security code:** Users must enter a night security code to place any calls while the system is in night mode. When this option is enabled, all stations are changed to complete line restriction (no outside calls are allowed) whenever the system is placed in night mode. Entering the four-digit night security code returns the station to its normal toll restriction/outgoing line access status.

NOTE: In order for option 7 to be enabled, option 5 must also be enabled.

- **Call forward to public network:** To allow keyset users to forward intercom and transferred calls to outside telephone numbers, one of the six CO lines must be designated for call forwarding to the public network. No CO lines are preset when the system is initialized.
- **Call forward DIL diversion line:** To allow *direct ring-in* calls to be forwarded to outside telephone numbers, you must also set up lines for call forward DIL diversion; this allows you to select the specific lines that will be allowed to forward calls to outside telephone numbers and exclude others, such as FX lines, WATS lines, and private lines. When a direct

ring-in call is forwarded to an outside telephone number, the station that is forwarded cannot be used for placing or receiving other calls while the forwarded call is in progress.

- **Dial pulse CO lines:** As the user dials a telephone number manually or uses speed dial or redial on a dial-pulse line, the system stores the digits in a buffer for conversion to dial-pulse signals. The user then hears the digits being sent out as the system dials the number

To Start The KSU Database Programming Session

5.3 TO BEGIN PROGRAMMING:

Ensure that the KSU PRG EN switch is in the ON position. Then, from the attendant's keyset (intercom number 10), program the system features as needed, using the table shown on the next page.

To End The KSU Database Programming Session

5.4 WHEN ALL PROGRAMMING IS COMPLETED

If no other programming is required for the system or stations, place the PRG EN switch in the OFF position.

CAUTION

It is important to return the PRG EN switch to the OFF position when finished. If the switch is left in the ON position, users could inadvertently change programming while using their stations. Also, the on/off feature codes for headsets, background music, call forwarding, and do-not-disturb cannot be used when the PRG EN switch is in the ON position.

TO PROGRAM:	DIAL:	THEN ENTER THIS:	WHEN FINISHED:
ATTENDANT RECALL TIMER	* 1 1	Enter the attendant recall time in seconds (0 or 60-600). <i>Default is 180 seconds.</i>	<p>Lift and replace the handset. You hear a confirmation tone.</p> <p>The DSS/BLF key for the station remains lit until the database has been updated.</p> <p>Do not continue programming until the DSS/BLF key is unlit.</p> <p>If you hear reorder tone, you entered an invalid value. Start over and enter the correct value.</p>
HOLD RECALL TIMER	* 1 2	Enter the hold recall time in seconds (0, 15-300). <i>Default is 60 seconds.</i>	
INACTIVITY TIMER	* 1 3	Enter the inactivity time in seconds (0, 15-60). <i>Default is 15 seconds.</i>	
CALL FORWARD TO PUBLIC NETWORK DURATION TIMER	* 1 4	Enter the call forward to public network duration time in seconds (30-900). <i>Default is 150 seconds.</i>	
CALL FORWARD TO PUBLIC NETWORK WARNING TIMER	* 1 5	Enter the call forward to public network warning time in seconds (0-150). NOTE: This is the amount of time between the warning signal and the end of the call. <i>Default is 30 seconds.</i>	
CALL FORWARD NO ANSWER TIMER	* 1 6	Enter the call forward no answer time in seconds (3-60). <i>Default is 15 seconds.</i>	
CO FLASH TIMER	* 2 1	Enter the CO flash time in tenths of a second (2-12). (2 = 0.2 sec., 12 = 1.2 sec.) <i>Default is 0.7 seconds.</i>	
CO DELAY TIMER	* 2 2	Enter the CO delay time in tenths of a second (1-50). (1 = 0.1 sec., 50 = 5.0 sec.) <i>Default is 2.5 seconds.</i>	
SPEED-DIAL PAUSE TIMER	* 2 4	Enter the speed-dial pause time in tenths of a second (10-50). (10 = 1.0 sec., 50 = 5.0 sec.) <i>Default is 3 seconds.</i>	
MEMORY-DIAL SPEED TIMER	* 2 5	Enter the memory-dial speed time in tenths of a second (1 or 2). (1 = 0.1 sec., 2 = 0.2 sec.) <i>Default is 0.1 seconds.</i>	
CO RING DURATION TIMER	* 2 7	Enter the CO ring duration time in tenths of a second (2-20). (2 = 0.2 sec., 20 = 2.0 sec.) NOTE: The recommended setting for this timer is 0.6-0.8 seconds. <i>Default is 0.4 seconds.</i>	
ABANDONED CALL TIMER	* 2 8	Enter the abandoned call time in $\frac{1}{10}$ second (40-200). (40 = 4.0 sec., 200 = 20.0 sec.) <i>Default is 6 seconds.</i>	
MAKE/BREAK RATIO TIMER	* 3 1	Enter one of the following numbers to designate the desired make/break ratio. <i>Default is 9 (64%).</i> 2 = 14% break 8 = 57% break 3 = 21% break 9 = 64% break 4 = 29% break 10 = 71% break 5 = 36% break 11 = 79% break 6 = 43% break 12 = 86% break 7 = 50% break	
PULSE-DIAL SPEED TIMER	* 3 2	Enter the pulse-dial speed (1 or 2). (1 = 0.1 sec., 2 = 0.2 sec.) <i>Default is 0.1 seconds.</i>	
PULSE-DIAL INTERDIGIT TIMER	* 3 3	Enter the pulse-dial interdigit time (6-10). (6 = 0.6 sec., 10 = 1.0 sec.) <i>Default is 0.8 seconds.</i>	
CO LINE EXCLUDED FROM TOLL RESTRICTION	# 4	Press the line key(s) of the CO line(s) that will not be subject to toll restriction. (To return to default status, skip this step.) <i>In default, no lines are excluded.</i>	
SYSTEM OPTIONS	# 5	Dial the desired option(s): 1, 2, or 3, plus 4-7 as needed. For example, dialing 147 will enable options 1, 4, and 7. (To return to default status, skip this step.) <i>Default is option 1 only.</i>	
CO LINE FOR CALL FORWARD TO THE PUBLIC NETWORK	# 6	Press the line key of the CO line that will be used to forward calls to the public network. (To return to default status, skip this step.) <i>In default, no line is programmed.</i>	
CO LINES FOR CALL FORWARD DIL DIVERSION	# 7	Press the line key(s) of the direct ring-in lines that may be forwarded to outside telephone numbers. DO NOT include the call forward to the public network line. <i>In default, no line is programmed.</i>	
DIAL-PULSE CO LINES	# 8	Press the line key(s) of the dial-pulse line(s). <i>In default, no line is programmed.</i>	
NIGHT SECURITY CODE	# 9	Enter a four-digit code that does not begin with *, #, 0, 1, 2, or 8. <i>Default is 9999.</i>	

B. STATION FEATURES PROGRAMMING

5.5 The following station features can be programmed using each station. For more information on these features, refer to the FEATURES section. Program entries as described below. Refer to page 5-8 for general programming information, if needed.

- **CO line restriction:** Designates the CO line(s) that cannot be used to make outgoing calls from the station. Only incoming calls, calls on hold, and recalls may be accessed on these CO lines. No CO lines are restricted during initialization. There is a special single-line port code for restricting all CO lines. It is used before initializing the APM. Refer to page 5-14 for details.
- **CO line ring-in assignment:** An incoming call on any line will cause the associated line key to flash on all keysets. If desired, this program can be used to designate the CO line(s) that will ring for incoming calls at the station. For example, if CO lines 1 and 2 are designated, calls will audibly ring in on those lines, but not on any other lines. When the system is initialized, only the attendant's station (intercom number 10) is assigned ring-in for all CO lines.
- **Station options:** No options are preset during initialization. Single-line stations can use options 3 and 6 only.
 - **Option 1 — Incoming page disable:** (*Keysets only*) Internal pages will not be heard through this keyset's speaker.
 - **Option 2 — Ring intercom first:** (*Keysets only*) Incoming intercom calls will ring until they are answered. The keyset user must press the ON/OFF key or lift the handset to answer intercom calls.
 - **Option 3 — Night answer:** Incoming calls programmed to ring in at the attendant's station will audibly ring in at this station when the system is in night ring mode. CO lines that are programmed to audibly ring only at stations other than the attendant's station are not affected by night ring mode. An incoming call causes the

associated line key to flash on all keysets in both day and night ring modes.

- **Option 4 — Speakerphone activation, pre-select disabled:** (*Keysets only*) Prevents the speakerphone from being activated automatically when a line key or an Executive Keyset's DSS/BLF key is pressed. When this option is enabled, the keyset user must press the ON/OFF key to activate the speakerphone.
- **Option 6 — Toll restrict:** Restricts toll-call dialing at the station, depending on the system options that were enabled.
- **Option 8 — Automatic line/intercom access:** (*Keysets only*) Allows the user to answer any outside or intercom call that is ringing in to the station by simply lifting the handset. Intercom calls that would normally be received handset-free still automatically activate the speakerphone, even if the keyset is ringing.

To Start The Station Features Programming Session

Place the PRG EN switch in the ON position. Then, from each station, program the station features as needed, using the tables shown on the next page.

To End The Station Features Programming Session

5.6 WHEN ALL STATIONS HAVE BEEN PROGRAMMED:

If no other programming is required for the system or stations, place the PRG EN switch in the OFF position.

CAUTION

It is important to return the PRG EN switch to the OFF position when finished. If the switch is left in the ON position, users could inadvertently change programming while using their stations. Also, the on/off feature codes for headsets, background music, call forwarding, and do-not-disturb cannot be used when the PRG EN switch is in the ON position.

Keyset Programming

5.7 All keyset programming is done while *on hook*. Each keyset circuit is programmed individually using the attached keyset. The DSS/BLF key for the station remains lit until the database has been updated. Do not continue programming until the DSS/BLF key is unlit.

TO PROGRAM:	DIAL:	THEN ENTER THIS:	WHEN FINISHED:
RESTRICTED CO LINES	# 1	Press the line key(s) for the line(s) that will be restricted. For example, pressing line keys 2 and 3 will prevent the station user from using CO lines 2 and 3 for outgoing calls. (To return to default status, skip this step.)	Lift and replace the handset. <i>If you hear reorder tone, you entered an invalid value. Start over and enter the correct value.</i>
CO LINES THAT WILL RING IN	# 2	Press the line key(s) that are to audibly ring for incoming calls at this station. (To return to default status, skip this step.)	
STATION OPTIONS	# 3	Dial the desired option(s). For example, dialing 123 will enable options 1, 2, and 3. (To return to default status, skip this step.)	

Single-Line Programming

5.8 All single-line programming is done while *off hook*. Each APM circuit (even if used for FAX or DISA) is programmed individually using an attached single-line set. The DSS/BLF key for the station remains lit until the database has been updated. Do not continue programming until the DSS/BLF key is unlit.

TO PROGRAM:	DIAL:	THEN ENTER THIS:	WHEN FINISHED:
RESTRICTED CO LINES	# 1	Enter the number(s) for the line(s) that will be restricted (1-6). For example, entering #123 will prevent the station user from using CO lines 2 and 3 for outgoing calls. To restrict all lines, use "All CO Lines Restricted" as described below. (To return to default status, skip this step.)	Hang up. When programming at a single-line station, have a keyset nearby so that you can watch the DSS/BLF key for the single-line station or wait 15 seconds before lifting the handset.
CO LINES THAT WILL RING IN	# 2	Enter the CO line access code(s) for the line(s) that are to audibly ring for incoming calls at this station. (To return to default status, skip this step.)	
STATION OPTIONS	# 3	<i>For proper single-line station operation, this must be set when the KSU is initialized.</i> Program options, dial the desired option number(s). For example, dialing 36 will enable options 3 and 6. NOTE: Single-line stations can use options 3 and 6 only. (To return to default status, enter only #3, without any station option numbers.)	<i>If you hear reorder tone, you entered an invalid value. Start over and enter the correct value.</i>
ALL CO LINES RESTRICTED	# 9	The station can be restricted from <i>all</i> CO lines using this code or from selected lines using "Restricted CO Lines" as described above.	

C. APM DATABASE PROGRAMMING

5.9 The APM software has single-line specific features that relate only to the single-line ports on the APM. Programming for these single-line port features is stored in the APM memory instead of the KSU system memory. The KSU system programming switch does not affect the APM database programming, therefore, the position of the switch (OFF or ON) will not interfere with any APM Database programming. However, any station options and features that are normally part of the KSU database programming are still programmed in the KSU database for the single-line stations (intercom numbers 20 and 21) using the procedure on page 5-10.

5.10 Once the APM has been initialized (see page 5-7 for procedures), the single-line ports can be programmed. Because the programming is independent to each port, the programming for the designated port *must* be programmed at that particular port. The only exceptions to this are the Single Line Hookflash Timers. These timers can be programmed from either port, but will affect both ports.

5.11 The following parameters are set when the APM database is initialized:

- Call Waiting Tones — Allowed
- Intercom Ring Cadence — Standard
- Single-line Minimum Hookflash — 200ms
- Single-line Maximum Hookflash — 700ms
- CO dB Padding — Disabled

IMPORTANT NOTE

It is important that, after initializing the APM, you place a call into the GLX-Plus System (using an outside telephone or one of the GLX-Plus stations and a CO line) and allow it to ring for two ring cycles. This procedure is necessary to allow the APM to synchronize flash rates for the single-line ports. *Failure to perform this step will cause erroneous APM port operation.*

5.12 Each single-line port is independently programmed using an industry standard 2500 set.

Call Waiting Tones

5.13 Call waiting tones can be disabled for each single-line port. This prevents call interruptions when a device such as a modem or a facsimile machine is attached. When the tones are disabled and a modem or FAX device is connected to a single-line port, incoming calls will not have call waiting tones interfering with the call.

5.14 The following steps are used to enable or disable Call Waiting Tones at a single-line port:

- (1) At the single-line port to be programmed, lift the handset and dial * 0 9 (APM Database Programming Mode).
- (2) Dial # 1 0 to disable call waiting tones or dial # 2 0 to enable call waiting tones. You will hear a confirmation tone.
- (3) Hang up

Ring Cadence

5.15 Some FAX machines cannot recognize the standard intercom ring cadence of the GLX-Plus System. This option allows the ring cadence to be extended when a FAX is attached to the single-line port. Not all FAX machines have the same tolerances for ring cadence detection.

5.16 The GLX-Plus standard intercom ring cadence is two, 0.2 second bursts of tone at two-second intervals. To allow some flexibility, the intercom ring cadence can be extended to a continuous ring pattern of 1 second ON/1 second OFF.

5.17 The extended intercom ring cadence does not affect the CO ring cadence when enabled.

5.18 The following procedures are used to program the incoming ring cadence for a single-line port:

- (1) At the single-line port to be programmed, lift the handset and dial * 0 9 (APM Database Programming Mode).
- (2) Dial # 1 1 for Extended ring cadence or dial # 2 1 for Standard ring cadence. You will hear a confirmation tone.
- (3) Hang up

Single-Line Hookflash Timers

NOTE: The Single-Line Hookflash timers must be set at least 0.1 seconds apart. For example, if the maximum timer is set for 0.4 seconds, the minimum timer must be 0.3 or lower.

5.19 The Single-Line Minimum Hookflash timer controls the minimum length of time that a single-line station must stay on hook for a hookflash to be recognized by the APM software. A hookflash shorter than this timer will be ignored by the APM software.

5.20 The timer has a default value of 0.2 seconds and a range of 0.1 seconds to 1.0 second.

5.21 The following steps are used to program this timer:

- (1) At the single-line port to be programmed, lift the handset and dial * 0 9 (APM Database Programming Mode).
- (2) Dial # 1 5 (Single Line Minimum Hookflash Timer) and the desired valid two-digit value for the timer in tenths of a second (01-10). For example, a timer setting of 0.5 seconds would require you to enter 05. You will hear a confirmation tone.
- (3) Hang up.

5.22 The Single Line Maximum Hookflash timer controls the maximum length of time that a single-line station can remain on hook for a hookflash to be recognized by the APM software. If the station remains on hook longer than this timer, the call is disconnected.

5.23 The timer has a default value of 0.7 seconds and a range of 0.2 seconds to 2.0 seconds.

5.24 The following steps are used to program this timer:

- (1) At the single-line port to be programmed, lift the handset and dial * 0 9 (APM Database Programming Mode).
- (2) Dial # 1 6 (Single Line Maximum Hookflash Timer) and the desired valid two-digit value for the timer in tenths of a second (02-20). For example, a timer setting of 0.5 seconds would require you to enter 05. You will hear a confirmation tone.
- (3) Hang up.

Single-Line Port dB Padding

5.25 Some single-line devices can produce distorted DTMF signals which may not be detected by the central office or other GLX-Plus stations. If desired, the audio path (transmit and receive) for the APM port can be attenuated by 3 dB. When the APM is initialized, the dB padding is disabled.

5.26 The following steps are used to program this feature:

- (1) At the single-line port to be programmed, lift the handset and dial * 0 9 (APM Database Programming Mode).
- (2) Dial # 1 3 to disable dB padding or dial # 2 3 to enable dB padding. You will hear a confirmation tone.
- (3) Hang up.

TROUBLESHOOTING

CONTENTS	PAGE
1. Introduction	6-1
2. Troubleshooting Checklist	6-1
3. Troubleshooting Charts	6-3
A. Features	6-3
B. Intercom	6-3
C. CO Lines	6-3
D. Keysets	6-3
E. Single-Line Sets	6-4
F. System Hardware	6-4
4. Customer Support	6-19
A. Technical Support	6-19
B. Emergency Assistance	6-19
5. Defective Unit Return Policy	6-19

1. INTRODUCTION

1.1 This section describes the troubleshooting procedures to follow in the event of a system or station instrument malfunction. System repair is limited to replacing parts — for example, KSU, Expansion PCB, Accessory Port Module (APM), keysets, etc.

2. TROUBLESHOOTING CHECKLIST

2.1 Use this troubleshooting checklist before you start the system troubleshooting procedures. It may save you time and possibly eliminate the need for detailed troubleshooting.

NOTE: In locations where there is low humidity, static can build up. This often causes small shocks or sparks when metal objects are touched. Although the internal metal components of the system are well insulated, a large static charge could cause an interruption in the system's digital signals. If this occurs, the system would perform a reset, which may cause dropped calls or reset features. If the KSU or keysets are located in high-static areas, take precautions to eliminate the static. If problems persist, contact Inter-Tel's Customer Support Department.

- (1) Is the problem caused by user errors? Use the feature according to the instructions in the FEATURES section of the manual.

- (2) Has the equipment been disconnected? Are the integrated circuits, PCBs, and equipment cables securely seated and connected? Refer to INSTALLATION for more information.

- (3) Is the RUN LED flashing or unlit?

If the RUN LED does not light:

- a. Check the AC fuse that is accessible from the right side of the KSU. If open, replace it (2A, 250V, slow-blow).
- b. Check the breaker to the isolated, dedicated, AC power source. If tripped, reset it.
- c. Connector J7 on the Main Control PCB is not connected properly. Refer to page 2-6 for the location of the connector.

If the RUN LED is flashing:

- a. There may be insufficient voltage available from the AC power source. Measure the AC voltage. If it is low, contact an electrician.
- b. If the AC power is sufficient, there is a problem on the Main Control PCB. Replace the KSU.

- (4) If the problem involves a programmable feature, place the PRG EN switch in the ON position and check the ERROR LED for an indication of a database error. (The ERROR LED will not flash unless the PRG EN switch is ON.)

NOTE: If the LED is not flashing, there may still be an error. Place the PWR switch in the OFF position for 10 seconds; then return it to the ON position. (Turning the PWR switch off drops all calls in progress.) If the LED flashes, a software error has occurred. Follow the procedures given below.

a. If the ERROR LED is flashing, an error has occurred in the system. Count the number of flashes between the 3-second pauses. Refer

to the chart below to determine the type of error.

b. Initializing the system will cause the ERROR LED to stop flashing for errors 6 and 7. If you do not wish to initialize and prefer to reprogram the affected area, manually stop the flashing LED by placing the PRG EN switch in the OFF position and then returning it to the ON position.

FLASHES	RESET INDICATION
1	ROM failure: A major system error has occurred. Place the PWR switch in the OFF position for 10 seconds, then return it to the ON position. If the flashing does not stop, replace the KSU.
6	<p>System/station programming: An error has been detected in one of the database programming areas. Either initialize the database or reprogram the areas that are affected. (User-programmable features such as call forwarding and night ring mode can be corrected by the keyset user or attendant.) Possible effects of the error include:</p> <ul style="list-style-type: none"> ● All lines are subject to toll restriction. ● No line is programmed for call forward to the public network. ● Keyset options are incorrect.* ● Ring-in assignments are incorrect.* ● Call forward mode is incorrect.* ● CO line restriction is incorrect.* ● Timers, night ring mode, and the system toll restriction option have been returned to default status. <p>*Can affect more than one keyset.</p>
7	System/station speed dialing: An error has been detected in one or more system or station speed-dial numbers. The faulty number has been erased and can be reprogrammed by the attendant or the keyset user.
8	Self-initialization: The software has performed a self-initialization. The software contains a self-testing feature that will automatically initialize the system when the database is not readable. This normally only occurs when the KSU power switch is first turned on and the PRG EN switch is in the ON position, and before the database back-up battery is enabled. To stop the LED flash, make sure the battery is enabled (paper is removed), and turn the PRG EN switch off, then on again.

3. TROUBLESHOOTING CHARTS

3.1 The simplified troubleshooting charts located on the following pages list symptoms, possible causes, and corrective actions for problems. Look up the problem in the appropriate chart and perform the corrective actions in the order given. The troubleshooting procedures for correcting equipment failures have been divided into the following six categories:

- A. Features
- B. Intercom Calls
- C. CO Calls
- D. Keysets
- E. Single-Line Sets
- F. System

NOTE: Throughout the troubleshooting section of the manual, there are numerous references to replacing the defective part and returning it for repair. However, before returning any part, proper troubleshooting procedures should be used to verify that the part is actually defective. For example, if a keyset appears to be defective, swap it with a "known good" keyset presently installed in the system. If the problem follows the suspect keyset, it can be considered defective. For more information on returning defective equipment, refer to page 6-19.

Some of the probable causes and corrective actions listed in the troubleshooting charts refer to the Expansion PCB and the APM. These are applicable only if the problem occurs at CO line 4, 5, or 6, or at stations 18, 19, 20, or 21.

A. FEATURES

3.2 If the problem involves system features:

- (1) Determine if the problem is due to user error. Perform the procedures as described in the FEATURES section.
- (2) If the feature still does not operate properly, proceed to Figure 6-1, Feature Troubleshooting Chart, on page 6-5.

3.3 The chart covers the following features:

- Cannot place a call on hold.
- Last number redial does not work.
- Speed-dial memory lost or not working.
- Headset enable, do-not-disturb, background music, and call forwarding codes do not work.
- Cannot initiate a conference.
- Cannot initiate a page.

- Call is not forwarded to the public network. Caller hears fast busy signal.
- Unable to interface with computer call-up device.
- Call privacy release is inoperative.

B. INTERCOM

3.4 If the problem is associated with intercom calls only, refer to Figure 6-2, Intercom Troubleshooting Chart, on page 6-8. The chart covers the following features:

- No intercom dial tone.
- Cannot place an intercom call. Intercom dial tone is present.

C. CO LINES

3.5 If the problem is associated with outside calls only, refer to Figure 6-3, CO Line Troubleshooting Chart, on page 6-9. The chart covers the following features:

- CO lines will not ring for incoming calls.
- CO line rings when a call is not ringing in.
- Cannot obtain CO dial tone.
- Cannot place an outgoing call. CO dial tone is present and intercom works.
- Other conversations can be heard on the line.
- Outside call is dropped upon answering or during conversation.
- CO line is inoperative throughout the system.

D. KEYSETS

3.6 If the problem is associated with a single keyset, refer to Figure 6-4, Keyset Troubleshooting Chart, on page 6-11. The chart covers the following features:

- Keyset does not receive intercom calls handsfree.
- Speakerphone not operating properly.
- Data noise heard through speakerphone or headset.
- Keyset has no power.
- Keyset squeals on outgoing calls or when receiving a handsfree call from a single-line station.
- Data device connected to keyset not operating properly.
- LRA device connected to keyset not operating properly.

E. SINGLE-LINE SETS

3.7 If the problem is associated with a single-line set, refer to Figure 6-5, Single-Line Set Troubleshooting Chart, on page 6-14. The troubleshooting charts cover the following features:

- Single-line set is completely inoperative.
- Single-line set inoperative; talk battery is present.
- Single-line set inoperative; calls ring in; talk battery is present.
- Single-line set receives CO ring-in, but cannot answer the call.
- Single-line set drops calls when transferring them or placing them on hold.
- DTMF digits dialed at single-line set cannot be detected by telco and/or other stations

- Intercom call to single-line set rings with CO ring cadence, not intercom ring cadence

F. SYSTEM HARDWARE

3.8 If the problem appears throughout the system, refer to Figure 6-6, System Troubleshooting Chart, on page 6-16. The troubleshooting charts cover the following features:

- All stations in the system are inoperative. No LEDs light when a CO line key is pressed.
- Several keysets are inoperative. No LEDs light when a CO line key is pressed.
- The single-line sets are inoperative.
- Music-on-hold is not present when an outside call is placed on hold.
- Repeated occurrence of dropped calls.
- RFI/EMI present over conversations.

FIGURE 6-1. FEATURE TROUBLESHOOTING CHART

SYMPTOM	PROBABLE CAUSE	CORRECTIVE ACTION
Cannot place a call on hold	User error	Refer to page 4-22.
	Defective station instrument	Perform GLX-Plus Keypad self-test (see page 3-24) and/or replace the station instrument.
	Defective Expansion PCB or APM	Replace Expansion PCB or APM.
	Defective Main Control PCB	Replace KSU or contact Inter-Tel Customer Support for assistance.

SYMPTOM	PROBABLE CAUSE	CORRECTIVE ACTION
Last number redial does not work	User error	Refer to page 4-33.
	Dialing speed too fast for PBX or central office	Change the memory-dial speed timer to 0.2. Refer to page 5-11.
	Defective keypad	Perform GLX-Plus Keypad self-test (see page 3-24) and/or replace the station instrument.
	Defective Expansion PCB or APM	Replace Expansion PCB or APM.
	Defective Main Control PCB	Replace KSU or contact Inter-Tel Customer Support for assistance.

SYMPTOM	PROBABLE CAUSE	CORRECTIVE ACTION
Speed-dial memory lost or not working	User error	Refer to page 4-32.
	Dialing speed too fast for PBX or Central Office	Change the memory-dial speed timer to 0.2. Refer to page 5-11.
	System error has occurred	Check the ERROR LED according to the instructions on page 6-1.
	Defective keypad	Perform GLX-Plus Keypad self-test (see page 3-24) and/or replace the station instrument.
	Defective Main Control PCB	Replace KSU or contact Inter-Tel Customer Support for assistance.

SYMPTOM	PROBABLE CAUSE	CORRECTIVE ACTION
Headset enable, do-not-disturb, background music and call forward codes do not work	PRG EN switch is in the ON position	PRG EN switch must be in the OFF position to enter these feature codes.

FIGURE 6-1. FEATURE TROUBLESHOOTING CHART (CONT'D)

SYMPTOM	PROBABLE CAUSE	CORRECTIVE ACTION
Cannot initiate a conference	User error	Refer to page 4-30.
	Conference circuits are busy	There are two conference circuits. When both are busy, the initiating party hears a busy signal. Inside parties are disconnected and outside parties are placed on individual hold.
	Intercom channels are busy	The initiating party must hang up and try again before adding an intercom call to the conference.
	Defective station instrument	Perform GLX-Plus Keypad self-test (see page 3-24) and/or replace the station instrument.
	Defective Expansion PCB or APM	Replace Expansion PCB or APM.
	Defective Main Control PCB	Replace KSU or contact Inter-Tel Customer Support for assistance.

SYMPTOM	PROBABLE CAUSE	CORRECTIVE ACTION
Cannot initiate a page	User error	Refer to page 4-25, for correct procedures.
	All stations in the paging zone are busy	Reorder tone is heard. Wait several seconds and then attempt to place the page again.
	All stations in the paging zone are in do-not-disturb	Reorder tone is heard if all stations in the zone are in do-not-disturb.
	Another external zone page is being made	Reorder tone is heard. Wait several seconds and then attempt to place the page again. Only one external zone page can be made at a time.
	All keysets have keypad option 1 enabled	Reprogram keysets to receive incoming pages (refer to page 5-13).
	Defective station instrument	Perform GLX-Plus Keypad self-test (see page 3-24) and/or replace the station instrument.
	Defective Expansion PCB or APM	Replace Expansion PCB or APM.
	Defective Main Control PCB	Replace KSU or contact Inter-Tel Customer Support for assistance.

FIGURE 6-1. FEATURE TROUBLESHOOTING CHART (CONT'D)

SYMPTOM	PROBABLE CAUSE	CORRECTIVE ACTION
Call is not forwarded to public network. Caller hears fast busy signal.	Call is toll-restricted or line is restricted	If both station instruments are toll-restricted or restricted from accessing the CO line, the call is restricted.
	Line is not programmed for call forwarding	A CO line must be programmed as the call forward to the public network line. Refer to page 5-11.
	Call forward line is busy	Caller must hang up and try call again later.
	Forward requests form a loop	If call forward requests form a loop (station instruments are forwarded to each other), incoming calls will not be forwarded.
	Station instrument not programmed correctly	Refer to page 4-26 for correct procedure.

SYMPTOM	PROBABLE CAUSE	CORRECTIVE ACTION
Unable to interface with computer call-up device (banking machine, answering machine, auto dialer, etc.)	Equipment being called is defective	Ensure that the called equipment is functioning correctly.
	DTMF digit duration/pause specifications of called equipment is incompatible with GLX-Plus System	Check with the equipment manufacturer for DTMF digit duration/pause specifications. Adjust memory-dial speed timer. Refer to page 5-11.
	CO trunk is designated for dial-pulse signaling	CO trunk must be designated as DTMF. Refer to page 5-11.
	Defective Expansion PCB or APM	Replace Expansion PCB or APM.
	Defective Main Control PCB	Replace KSU or contact Inter-Tel Customer Support for assistance.

SYMPTOM	PROBABLE CAUSE	CORRECTIVE ACTION
Call privacy release inoperative	User error	Keyset user must lift the handset or press the ON/OFF key before pressing the busy CO line key.
	Call is forced private	Refer to page 4-29 for information on call privacy and privacy release.
	Programming error	Verify that system-wide CO privacy release option is enabled. See page 5-11.

FIGURE 6-2. INTERCOM TROUBLESHOOTING CHART

NOTE: These symptoms are isolated to one station instrument only. For identical problems involving more than one station instrument, refer to Figure 6-6, System Troubleshooting Chart, on page 6-16.

SYMPTOM	PROBABLE CAUSE	CORRECTIVE ACTION
No intercom dial tone	Defective station cabling	Check cable connections.
	Defective station instrument	Perform GLX-Plus Keyset self-test (see page 3-24) and/or replace the station instrument.
	Defective Expansion PCB or APM	Replace Expansion PCB or APM.
	Defective Main Control PCB	Replace KSU or contact Inter-Tel Customer Support for assistance.

SYMPTOM	PROBABLE CAUSE	CORRECTIVE ACTION
Cannot place intercom call. Intercom dial tone is present.	Invalid or unequipped intercom number dialed	Verify that a valid and equipped intercom number was dialed (10-21).
	Defective station instrument	Perform GLX-Plus Keyset self-test (see page 3-24) and/or replace the station instrument.
	Defective Expansion PCB or APM	Replace Expansion PCB or APM.
	Defective Main Control PCB	Replace KSU or contact Inter-Tel Customer Support for assistance.

FIGURE 6-3. CO LINE TROUBLESHOOTING CHART

SYMPTOM	PROBABLE CAUSE	CORRECTIVE ACTION
CO lines will not ring for incoming calls	CO ring duration timer is set too long	Attach a lineman's test set to one of the lines at the RJ connector. Place an outgoing call that will ring in on the line with the test set. Check for ring signal. If you hear ring signal, set the timer to a shorter duration. Refer to page 5-11. If you do not hear ring signal, notify the telephone company. (The minimum ringing voltage the system will recognize is 40VAC.)

SYMPTOM	PROBABLE CAUSE	CORRECTIVE ACTION
CO line rings when a call is not ringing in (false ring-in)	CO ring duration timer is set too short	Noise on the CO line is causing false ring-in. Set the timer to a longer duration. Refer to page 5-11.

SYMPTOM	PROBABLE CAUSE	CORRECTIVE ACTION
Cannot obtain CO dial tone	Station has been restricted from CO line(s) for placing calls	Check the programming for the station and reprogram is necessary. Refer to page 5-13.
	Central office is not supplying dial tone	Attach a lineman's test set to each line at the RJ and check for CO dial tone. If not present, contact the telephone company.
	Defective station instrument	Perform GLX-Plus Keypad self-test (see page 3-24) and/or replace the station instrument.
	CO line(s) disconnected	Check every CO line connection between the RJ and the KSU.
	Defective Expansion PCB or APM	Replace Expansion PCB or APM.
	Defective Main Control PCB	Replace KSU or contact Inter-Tel Customer Support for assistance.

SYMPTOM	PROBABLE CAUSE	CORRECTIVE ACTION
Cannot place an outside call. CO dial tone is present and intercom works.	CO line uses dial-pulse signal	When the system is initialized, all CO lines are designated as DTMF lines. One or more lines can be converted to dial-pulse through programming. See pages 5-10 and 5-11.
	Keypad is toll restricted (keypad option 6 enabled)	Check the programming for the keypad and reprogram if necessary (refer to page 5-13).
	Defective station instrument	Perform GLX-Plus Keypad self-test (see page 3-24) and/or replace the station instrument.
	Defective Expansion PCB or APM	Replace Expansion PCB or APM.
	Defective Main Control PCB	Replace KSU or contact Inter-Tel Customer Support for assistance.

FIGURE 6-3. CO LINE TROUBLESHOOTING CHART (CONT'D)

SYMPTOM	PROBABLE CAUSE	CORRECTIVE ACTION
Other conversations can be heard on the line (crosstalk)	Defective CO line(s)	Attach a lineman's test set to each line at the RJ connector and check for cross-talk. If present, contact the telephone company.
	CO lines miswired	Check every CO line connection between the RJ connector and the KSU.
	Defective Expansion PCB or APM	Replace Expansion PCB or APM
	Defective Main Control PCB	Replace KSU or contact Inter-Tel Customer Support for assistance.

SYMPTOM	PROBABLE CAUSE	CORRECTIVE ACTION
Outside call dropped upon answering or during conversation	User error (line key pressed after initial connection is made)	Pressing a line key after the connection has been made will automatically drop the call in progress and reseat that CO line.
	User error (digit key pressed after connection is made)	The system counts the number of digits dialed when the station instrument is toll restricted. If the user dials more digits than are allowed by toll restriction, the call will be dropped (even if the call is in progress).
	Database error	Refer to the ERROR LED procedures on page 6-1.
	Defective station instrument	Perform GLX-Plus Keypad self-test (see page 3-24) and/or replace the station instrument.
	Defective Expansion PCB or APM	Replace Expansion PCB or APM.
	Defective Main Control PCB	Replace KSU or contact Inter-Tel Customer Support for assistance.

SYMPTOM	PROBABLE CAUSE	CORRECTIVE ACTION
CO line is inoperative throughout the system	Defective CO line from central office	Attach a lineman's test set the line at the RJ connector and check for CO dial tone. If not present, contact the telephone company.
	CO lines miswired	Check CO line connections between the RJ and the KSU.
	All station instruments have been restricted from accessing CO line	Check programming for every station and reprogram if necessary. Refer to page 5-13.
	Defective or missing Expansion PCB or APM	Replace or install Expansion PCB or APM.
	Defective Main Control PCB	Replace KSU or contact Inter-Tel Customer Support for assistance.

FIGURE 6-4. KEYSSET TROUBLESHOOTING CHART

SYMPTOM	PROBABLE CAUSE	CORRECTIVE ACTION
Keypad does not receive intercom calls handsfree	Keypad option 2 is enabled	This option causes all incoming calls to ring in as private calls. The keypad user must press the ON/OFF key or lift the handset to answer.
	Defective keypad	Perform GLX-Plus Keypad self-test (see page 3-24) and/or replace the station instrument.

SYMPTOM	PROBABLE CAUSE	CORRECTIVE ACTION
Speakerphone not operating properly	User error	Refer to page 4-6 and 4-18.
	Automatic speakerphone is disabled	Speakerphone will not activate automatically when keypad option 4 is enabled. Refer to page 5-13.
	Headset is enabled	When a headset is enabled, the speakerphone will not operate. When disconnecting a headset, enter the headset feature code to return the keypad to normal operation.
	Defective keypad	Perform GLX-Plus Keypad self-test (see page 3-24) and/or replace the station instrument.
	Defective Expansion PCB or APM	Replace Expansion PCB or APM.
	Defective Main Control PCB	Replace KSU or contact Inter-Tel Customer Support for assistance.

SYMPTOM	PROBABLE CAUSE	CORRECTIVE ACTION
Data noise heard through speakerphone or handset	System does not have an isolated, dedicated, AC outlet	The ground wire must be dedicated to the outlet. Run the power, neutral, and ground wires directly from a separate circuit in the breaker box to the outlet. Install a surge/spike protector with RFI and EMI noise filtering.
	Defective or loose cable connections	Check for loose, open, or crossed wires, and correct.
	Station cable exposed to interference	Ensure proper station cable runs. Refer to page 3-6.
	Defective keypad	Perform GLX-Plus Keypad self-test (see page 3-24) and/or replace the station instrument.
	Defective Expansion PCB or APM	Replace Expansion PCB or APM.
	Defective Main Control PCB	Replace KSU or contact Inter-Tel Customer Support for assistance.

FIGURE 6-4. KEYSSET TROUBLESHOOTING CHART (CONT'D)

SYMPTOM	PROBABLE CAUSE	CORRECTIVE ACTION
Keyset has no power	Defective station fuse on Main Control PCB	Check the three fuses. Replace defective fuse (1A, 250V, fast-acting). Each fuse affects up to four keysets. F1 protects keysets 10-13, F2 protects 14-17, and F3 protects 18-21.
	Defective keyset	Test the circuit with a known good keyset. If the known good keyset powers up, replace the defective keyset.
	Defective cabling	Check cabling for shorts (or open connections) and correct polarity.
	Defective Expansion PCB or APM	Replace Expansion PCB or APM.
	Defective Main Control PCB	Replace KSU or contact Inter-Tel Customer Support for assistance.

SYMPTOM	PROBABLE CAUSE	CORRECTIVE ACTION
Keyset squeals on outside calls or when receiving a handsfree intercom call from a single-line station (feedback)	Speaker volume is too loud	Reduce feedback by lowering speaker volume using keyset volume controls.
	Poor acoustics	Poor acoustics can cause poor quality on handsfree calls. Try placing a private call.
	Defective Expansion PCB or APM	Replace Expansion PCB or APM.
	Defective Main Control PCB	Replace KSU or contact Inter-Tel Customer Support for assistance.

SYMPTOM	PROBABLE CAUSE	CORRECTIVE ACTION
Data device connected to keyset not operating properly	User error	Refer to manufacturer's operating instructions.
	Problem with data device	Disconnect data device and check operation according to the manufacturer's instructions.
	Data Port Module not installed properly or defective	Check Data Port Module installation and jumper strap settings. Refer to page 3-27. Replace if defective.
	Defective keyset	Perform GLX-Plus Keyset self-test (see page 3-24) and/or replace the station instrument.
	Defective Expansion PCB or APM	Replace Expansion PCB or APM.
	Defective Main Control PCB	Replace KSU or contact Inter-Tel Customer Support for assistance.

FIGURE 6-4. KEYSSET TROUBLESHOOTING CHART (CONT'D)

SYMPTOM	PROBABLE CAUSE	CORRECTIVE ACTION
LRA device connected to keyset not operating properly	Problem with LRA device	Disconnect LRA device and check operation according to the manufacturer's instructions.
	Data Port Module not installed properly or defective	Check Data Port Module installation and jumper strap settings. Refer to page 3-27. Replace if defective.
	LRA feature disabled	Refer to page 4-11 for information on enabling the LRA feature.
	Defective keyset	Perform GLX-Plus Keyset self-test (see page 3-24) and/or replace the station instrument.
	Defective Expansion PCB or APM	Replace Expansion PCB or APM.
	Defective Main Control PCB	Replace KSU or contact Inter-Tel Customer Support for assistance.

FIGURE 6-5. SINGLE-LINE SET TROUBLESHOOTING CHART

SYMPTOM	PROBABLE CAUSE	CORRECTIVE ACTION
Single-line set is completely inoperative	Defective set	Test the circuit with a known good SL set. If the known good SL set powers up, replace the defective SL set.
	Defective cabling	Check amphenol connector and station cabling. Refer to pages 3-6 to 3-10.
	APM not properly installed	Ensure APM is properly seated and installed. See page 3-16.
	Defective APM	Replace the APM.
	Defective Main Control PCB	Replace KSU or contact Inter-Tel Customer Support for assistance.

SYMPTOM	PROBABLE CAUSE	CORRECTIVE ACTION
Single-line set inoperative; talk battery present	Defective set	Replace the single-line set.
	Defective APM	Replace the APM.
	Defective Main Control PCB	Replace KSU or contact Inter-Tel Customer Support for assistance.

SYMPTOM	PROBABLE CAUSE	CORRECTIVE ACTION
Single-line set inoperative; calls ring in; talk battery is present	Defective set	Replace the single-line set.
	Defective APM	Replace the APM.
	Defective Main Control PCB	Replace KSU or contact Inter-Tel Customer Support for assistance.

SYMPTOM	PROBABLE CAUSE	CORRECTIVE ACTION
Single-line set receives CO ring in, but cannot answer call	APM software not initialized or specific APM port not initialized	Initialize the APM software and/or port as outlined on pages 5-6 and 5-7.
	APM software not properly synchronized with the KSU	To synchronize single-line set flash rates with the KSU, place a call into the system using one of the APM single-line ports and allow it to ring for two ring cycles. See page 5-7.

SYMPTOM	PROBABLE CAUSE	CORRECTIVE ACTION
Single-line set drops calls when transferring them or placing them on hold	SL minimum and maximum hookflash timers not set properly	Adjust minimum and/or maximum hookflash timers. Refer to page 5-11.

FIGURE 6-5. SINGLE-LINE SET TROUBLESHOOTING CHART (CONT'D)

SYMPTOM	PROBABLE CAUSE	CORRECTIVE ACTION
DTMF digits dialed at single-line set cannot be detected by telco and/or other stations	Single-line device producing distorted DTMF signals	The audio path (transmit and receive) of the associated APM port can be attenuated by 3 dB. See page 5-15.
	Defective set	Replace the single-line set.
	Defective APM	Replace the APM.
	Defective Main Control PCB	Replace KSU or contact Inter-Tel Customer Support for assistance.

SYMPTOM	PROBABLE CAUSE	CORRECTIVE ACTION
Intercom call to single-line set rings with CO ring cadence, not intercom ring cadence	APM software not initialized or specific APM port not initialized	Initialize the APM software and/or port as outlined on pages 5-6 and 5-7.

CUMMINGS

FIGURE 6-6. SYSTEM TROUBLESHOOTING CHART

SYMPTOM	PROBABLE CAUSE	CORRECTIVE ACTION
All stations in the system are inoperative. No LEDs light when a CO line key is pressed.	KSU AC power cord is not plugged in.	Plug cord into isolated, dedicated, AC outlet.
	Dedicated breaker has tripped.	Reset breaker.
	AC fuse is open	Replace fuse (2A, 250V, slow-blow).
	Station fuse(s) are open	Check the three fuses on the Main Control PCB. Replace fuse(s) (1A, 250V, fast-acting). Each fuse affects up to four station instruments. F1 protects station instrument 10-13, F2 protects 14-17, and F3 protects 18-21. Check station cabling for error (refer to page 3-6).
	Defective Main Control PCB	Replace KSU or contact Inter-Tel Customer Support for assistance.
	Defective power supply	Replace KSU.

NOTE: If the system is operating on system battery back-up power, the batteries may not have enough charge to power the system.

SYMPTOM	PROBABLE CAUSE	CORRECTIVE ACTION
Several keysets are inoperative. No LEDs light when CO line key is pressed.	Defective station fuse(s) on Main Control PCB	Check the three fuses. Replace defective fuse (1A, 250V, fast-acting). Each fuse affects up to four station instruments. F1 protects station instruments 10-13, F2 protects 14-17, and F3 protects 18-21. Check station cabling for error (refer to page 3-6).
	Missing or Defective Expansion PCB or APM	Install or Replace Expansion PCB or APM.
	Defective Main Control PCB	Replace KSU or contact Inter-Tel Customer Support for assistance.

SYMPTOM	PROBABLE CAUSE	CORRECTIVE ACTION
Single-line stations are inoperative.	Defective APM	Replace APM.
	Defective Main Control PCB	Replace KSU or contact Inter-Tel Customer Support for assistance.

FIGURE 6-6. SYSTEM TROUBLESHOOTING CHART (CONT'D)

SYMPTOM	PROBABLE CAUSE	CORRECTIVE ACTION
Music-on-hold not present when outside call is placed on hold	Music-on-hold channels are in use	The system has two music-on-hold channels. If two outside calls are placed on hold, a third caller will not hear music if placed on hold.
	Music source is not working	Check the music source. Also check its input level at connector J6 on the Main Control PCB by placing a meter across pins 1 and 2. The optimum input level is 1.0VRMS.
	Defective cabling to the KSU	Check the cable to the music jack; repair if needed.
	Defective KSU	Replace KSU or contact Inter-Tel Customer Support for assistance.

SYMPTOM	PROBABLE CAUSE	CORRECTIVE ACTION
Repeated occurrence of dropped calls	AC outlet is not isolated and dedicated	The ground wire must be dedicated to the outlet. Run the power, neutral, and ground wires directly from a separate circuit in the breaker box to the outlet. A surge/spike protector with RFI and EMI noise filtering should be installed.
	The KSU is near a strong magnetic field (heavy motor, copy machine, etc.)	Relocate the KSU so that it is not affected by the magnetic field.
	Database error	Refer to ERROR LED procedures on page 6-1.
	Defective power supply	Replace KSU.
	Defective Main Control PCB	Replace KSU or contact Inter-Tel Customer Support for assistance.

FIGURE 6-6. SYSTEM TROUBLESHOOTING CHART (CONT'D)

SYMPTOM	PROBABLE CAUSE	CORRECTIVE ACTION
Radio frequency interference (RFI) or electromagnetic interference (EMI) present over conversations	AC power source or grounding incorrect	Verify that the AC circuit is isolated and dedicated (see page 3-4) and check for proper grounding (see page 3-19).
	Grounding point is source of RFI/EMI	While the system is running on AC power, temporarily remove the grounding wire to determine if it is the source of the RFI/EMI. See page 3-19 for proper grounding requirements.
	AC power source is causing RFI/EMI	If an external battery back-up power source is installed, switch system operation to battery back-up power by unplugging the power source's AC power cord (with grounding wire connected to equipment cabinet). If RFI/EMI stops, the AC power source is the cause. Install an RFI/EMI filter or equivalent on the AC outlet.

NOTE: For further RFI/EMI troubleshooting assistance *while on site*, technicians should contact Customer Support with the following information:

1. Modulation — AM, FM, or other
2. Frequency of the interfering station (in Hz)
3. Broadcast power
4. Distance between equipment cabinet and broadcast antenna
5. Who hears RFI:
 - Outside call — inside party only?
 - Outside call — outside party only?
 - Outside call — both parties?
 - Intercom call — one or both parties?
6. Type of instrument(s) on which RFI is heard — Standard Keyset, Executive Keyset, GLX-Plus Keyset, or single-line DTMF set

4. CUSTOMER SUPPORT

A. TECHNICAL SUPPORT

4.1 If problems persist when installing or servicing Inter-Tel equipment: While *on site* and *with the proper troubleshooting tools available*, contact Inter-Tel's Customer Support Department for assistance. They can be reached from 7:00 A.M. to 5:00 P.M. Mountain Standard Time at 602-961-9000 or 1-800-669-5858.

B. EMERGENCY ASSISTANCE

4.2 After office hours and on weekends, call 602-961-0277 and leave your message with the voice mail service. A Customer Support Product Specialist will return your call as soon as possible, usually within an hour. Please remember that this is an emergency number for *critical system problems only*. Sales questions, equipment orders, etc., can only be handled during normal business hours.

5. DEFECTIVE UNIT RETURN POLICY

IMPORTANT

For complete information on returning equipment, refer to the *current* Inter-Tel Incorporated Material Return Policy (document part number 835.1065). This document includes specific information on the following subjects: warranty, procedures to follow when returning equipment, equipment damaged in shipment, insurance, repair policy, and advance replacement policy.

5.1 TO RETURN A DEFECTIVE UNIT FOR REPAIR:

- (1) Obtain an MRA number from Inter-Tel's Order Processing Department. Write the MRA number and ATTN: MRA on the outside of each carton being returned. *INTER-TEL DOES NOT ACCEPT EQUIPMENT IF THE MRA NUMBER IS NOT ON THE CARTON.*
- (2) On the repair tag, identify the unit by the equipment name, part number, and serial number. (Repair tags are available from Inter-Tel.)
- (3) Describe the defect in detail and, if applicable, the circuit number related to the defect. Document the estimated length of time the part had been in service prior to the failure. *ALL EQUIPMENT RETURNED FOR REPAIR MUST BE TAGGED WITH COMPLETE DETAILED INFORMATION REGARDING THE DEFECT OR IDENTIFICATION OF THE PROBLEM.*
- (4) Attach the upper portion of the repair tag to the defective equipment. Retain the bottom portion for your files.
- (5) Properly package the equipment for shipping (i.e., return in original package or equivalent). *WARRANTY MAY BE VOIDED IF EQUIPMENT IS IMPROPERLY PACKAGED.*

REPLACEMENT PARTS

<i>CONTENTS</i>	<i>PAGE</i>
1. Introduction	7-1
2. Ordering Procedure	7-1
3. Replacement Parts List	7-1
4. Recommended Spare Parts	7-1

1. INTRODUCTION

1.1 This section provides the information necessary to order and stock replacement parts for the GLX-Plus System.

- Part number(s) of equipment ordered
- Quantity required

2. ORDERING PROCEDURE

2.1 When ordering equipment for the GLX-Plus System, provide the following information to the order processing clerk:

- Company name
- Purchase order number
- Required date of shipment

3. REPLACEMENT PARTS LIST

3.1 Figure 7-1 lists authorized parts available for replacement on the GLX-Plus System.

4. RECOMMENDED SPARE PARTS

4.1 *It is mandatory that spare parts be kept on hand to ensure the best possible customer service.*

4.2 Figure 7-2 on page 7-2 lists the quantities of spare parts recommended to adequately maintain and service ten GLX-Plus Systems.

FIGURE 7-1. REPLACEMENT PARTS

<u>DESCRIPTION</u>	<u>PART NUMBER</u>
Station Instruments	
Standard Keypad	612.3000
Executive Keypad	612.3100
GLX-Plus Display Keypad	612.4200
GLX-Plus Non-Display Keypad	612.4300
KSU	
KSU Assembly	612.1000
Expansion PCB	612.2010
Accessory Port Module (APM)	612.2300
Miscellaneous Equipment	
Data Port Module Kit	828.1094
Liquid Crystal Display (LCD) Kit	828.1188

FIGURE 7-1. REPLACEMENT PARTS (CONT'D)

<u>DESCRIPTION</u>	<u>PART NUMBER</u>
Manuals	
Installation & Field Maintenance Manual	612.8001
Owner's Guide	612.8004
Standard Keypad User Guide	612.8002
Executive Keypad User Guide	612.8003
GLX-Plus Keypad User Guide	612.8012
Single-Line User Guide	612.8014

FIGURE 7-2. RECOMMENDED SPARE PARTS

<u>DESCRIPTION</u>	<u>QUANTITY</u>	<u>PART NO.</u>
KSU Assembly	1	612.1000
Expansion PCB	1	612.2010
APM	1	612.2300
Standard Keypad	2	612.3000
Executive Keypad	2	612.3100
GLX-Plus Non-Display Keypad	2	612.4300
LCD Kit	2	828.1188

A

- Abandoned call timer, 5-9, 5-11
- Accessory Port Module (APM), 2-5, 4-12
 - database programming, 5-14
 - installation, 3-16
 - programming, 5-5
 - software, 5-6, 5-7
- Account codes, 4-19
- Altitude, 2-3, 3-4
- Answering machine, 2-12
- Attendant
 - features, 1-3, 4-43
 - night mode, 4-43
 - night security code, 4-43
 - recall, 4-43
 - system speed dial programming, 4-44
- Attendant recall timer, 5-8, 5-11
- Automatic line/intercom access, 4-8, 5-12, 5-13

B

- Background music, 4-15
- Battery back-up
 - database, 4-5
 - GLX-Plus keyset, 2-11, 3-30, 4-5
 - system, 2-12, 3-33, 4-5
- Busy signal, 4-14

C

- Cabling, 2-2
 - connection to MDF, 3-8, 3-12, 3-14
 - guidelines, 3-6
 - lines, 2-2
 - loop limits, 3-4, 3-6, 3-11
 - station, 2-2, 3-5, 3-6, 3-7
- Call forward no answer timer, 5-8, 5-11
- Call forward to the public network timer, 5-8, 5-11
- Call forward to the public network warning timer, 5-8, 5-11
- Call forwarding. *See* Forwarding
- Call pick-up, 4-24
- Call privacy release/restore, 4-29
 - troubleshooting, 6-7
- Call transfer. *See* Transfer
- Call waiting, 4-23

tones, 4-12, 4-23, 5-14

- Callback (queue), 4-20
 - capacity, 1-3
- Capacity
 - features, 1-3
 - stations, 2-9
- Central office (CO) lines
 - cabling, 2-2
 - connection to MDF
 - RJ14 jack, 3-12
 - RJ21X block, 3-14
 - dial pulse, 4-4, 5-3, 5-10, 5-11
 - exclude from toll restrictions, 4-5
 - features, 4-4
 - lightning protection, 2-2, 3-12
 - repeaters, 2-12
 - restriction, 4-4, 5-12, 5-13
 - ring-in, 5-12, 5-13
 - troubleshooting, 6-3, 6-9, 6-10
- CO delay timer, 5-9, 5-11
- CO flash timer, 5-8, 5-11
- CO ring duration timer, 5-9, 5-11
- Conferencing, 4-30
 - capacity, 1-3
 - troubleshooting, 6-6
- Consultation hold, 4-22
- Customer support, 6-19

D

- Data device, 4-10
 - installation, 3-27
 - specifications, 2-10
 - troubleshooting, 6-12
- Data port module
 - installation, 3-27
 - specifications, 2-10
- Database battery back-up, 4-5
- Database reports, 4-38
- Date
 - GLX-Plus display, 4-34
 - SMDR, 4-36
- Dedicated, isolated circuit, 2-5, 3-4
- Defective unit return policy, 6-19
- Dial tone, 4-14
 - restore, 4-20
- Dial-pulse signaling, 4-4
 - programming, 5-10, 5-11

DIL diversion line, 5-10, 5-11
Direct Station Selection/Busy Lamp Field (DSS/BLF)
 keys, 4-8
 key skipping, 4-17
Displays, 2-9
Do-not-disturb, 4-33
Doorbox, 2-12, 4-13
Dual-tone multi-frequency (DTMF) signaling, 4-4

E

Emergency assistance, 6-19
Environmental requirements, 2-3, 3-4
ERROR LED, 6-1
 flash indications, 6-2
Exclude lines from toll restriction option, 5-9, 5-11
Expansion PCB, 2-5
 installation, 3-16
External music source, 3-31
External paging, 4-25
 port capacity, 1-3
 speakers, 3-31

F

Facsimile (FAX) machine, 2-13
FCC regulations, Page vii
Feature codes, 4-3
Feature keys, 4-3, 4-6
Features
 attendant, 1-3
 keysets, 1-2
 optional, 1-2
 requiring additional equipment, 1-2
 single-line, 1-3
 summary, 1-2
 system, 1-2
 troubleshooting, 6-3
Feedback on keysets, 6-12
Flexible incoming ring assignment, 4-4
Flexible night ring assignment, 4-4

Forward to the public network
 programming, 5-10, 5-11
 timers, 5-8, 5-11
 troubleshooting, 6-7
Forwarding, 4-26
 DIL diversion line, 5-10, 5-11
 line programming, 5-3
 timers, 5-8, 5-11
 to outside number, 4-26
 to voice mail, 4-13, 4-27

G

Gas discharge tubes, 2-2, 3-12
GLX-Plus keyset, 4-6
 battery back-up, 2-11, 3-30, 4-5
 time/date display, 4-34
 volume control, 4-9
Grounding, 3-19

H

Handset amplifiers, 2-10
 installation, 3-25
Handsfree enable/disable, 4-16
Hardware troubleshooting, 6-4
Headsets, 2-10, 4-9
 installation, 3-25
 troubleshooting, 6-5
Hold
 conference parties, 4-31
 consultation, 4-22
 individual, 4-22
 recall, 4-22
 system, 4-22
 troubleshooting, 6-5
Hold recall, 4-22
 timer, 5-8, 5-11
Hookflash, 4-16
 timer, 4-12, 5-8, 5-11, 5-15
Humidity, 2-3, 3-4

I
Inactivity timer, 5-8, 5-11
Individual hold, 4-22
Initializing the system, 5-6

Installation

- outline, 3-2
- post-installation checklist, 3-33
- pre-installation checklist, 3-4
- tools and supplies, 3-4

Integrated speakerphone, 2-9, 4-6

Intercom calls, 4-16

- DSS/BLF key skipping, 4-17
- placing/receiving, 4-16
- private, 4-16
- troubleshooting, 6-3, 6-8

Internal paging, 4-25

Isolated, dedicated circuit, 2-5, 3-4

K

Key Service Unit (KSU), 2-3

- APM, 2-5, 3-16
- environmental requirements, 2-3, 3-4
- Expansion PCB, 2-5, 3-16
- grounding, 3-19
- installation, 3-15
- Main Control PCB, 2-5
- power supply, 2-5
- programming, 5-10
- software, 5-6, 5-7
- wall mounting, 3-18

Keysets, 2-9, 4-6

- automatic call access, 4-8
- cabling, 3-5
- capacity, 2-9
- data devices, 4-10
- data port module, 2-10, 3-27
- dimensions, 2-9
- feature keys, 4-6
- features, 1-2
- feedback, 6-12
- handset amplifiers, 2-10, 3-25
- handsfree enable/disable, 4-16
- headsets, 2-10, 3-25, 4-9
- installation, 3-22, 3-24
- LCD, 2-9, 3-22
- LEDs, 4-7
- line keys, 4-6
- loud ringing adapter, 2-10, 4-11
- programming, 5-13
- selectable ring tone, 4-8
- speakerphone, 2-9, 4-6
- troubleshooting, 6-3, 6-11, 6-12
- volume controls, 4-9
- wall mounting, 3-26

L

Light-emitting diodes (LEDs)

- keyset, 4-7
- troubleshooting, 6-1

Lightning protection, 2-2, 3-12

Line keys, 4-6

- skipping, 4-21

Line restriction, 4-4, 5-12, 5-13

Liquid crystal display (LCD), 2-9

- installation, 3-22

Loop limits for cabling, 3-4, 3-6, 3-11

Loud ringing adapter (LRA), 4-11

- installation, 3-29
- specifications, 2-10
- troubleshooting, 6-13

M

Main Control PCB, 2-5

Main distribution frame (MDF), 2-2

- assembling, 3-8
- backboard, 3-8
- line connections
 - RJ14 jack, 3-12
 - RJ21X block, 3-14
- station connections, 3-8, 3-10
- terminal blocks, 3-8

Make/break ratio timer, 5-9, 5-11

Material return authorization (MRA), 6-19

Material Return Policy (MRA), x

Memory-dial speed timer, 5-9, 5-11

Modular jack assembly

- lines, 3-13
- stations, 3-7, 3-24

Music source, 3-31

Music-on-hold, 4-15

- troubleshooting, 6-17

N

Night answer, 5-12, 5-13

Night mode, 4-4, 4-43

- security code, 4-21

Night security code, 4-21

- program planning, 5-3
- programming, 4-43
- programming option, 5-9, 5-10, 5-11

O

- Operating temperature, 2-3
- Optional equipment, 2-12
 - installation, 3-5
 - station
 - data port module, 2-10, 3-27
 - handset amplifiers, 2-10, 3-25
 - headsets, 2-10, 3-25
 - system, 2-1, 2-12
 - answering machine, 2-12
 - battery back-up, 2-12
 - doorbox, 2-12
 - external music source, 3-31
 - external paging speakers, 3-31
 - FAX, 2-13
 - repeaters, 2-12
 - SMDR device, 2-13
 - voice mail unit, 2-12

Optional features, 1-2

Ordering parts, 7-1

- Outside calls, 4-18-4-21
 - account codes, 4-19
 - callback (queue), 4-20
 - dial tone restore, 4-20
 - line key skipping, 4-21
 - night security code, 4-21
 - placing/receiving, 4-18

P

- Paging, 4-25
 - capacity, 1-3
 - enable/disable, 5-12, 5-13
 - external speakers, 3-31
 - troubleshooting, 6-6
- Part numbers, 7-1
- Post-installation checklist, 3-33
- Power failure back-up, 4-5
- Power supply. *See* System power supply
- PRG EN switch, 5-10
- Privacy release/restore, 4-29
 - programming, 5-10, 5-11
 - troubleshooting, 6-7

Private intercom calls, 4-16

- Programming
 - database report, 4-38
 - outline, 5-1
 - planning sheets, 5-1, 5-2
 - start/stop, 5-10
 - station features, 5-8, 5-12
 - system features, 5-8

Pulse-dial interdigit timer, 5-9, 5-11

Pulse-dial speed timer, 5-9, 5-11

Q

- Queue, 4-20
 - capacity, 1-3

R

- Recall
 - attendant, 4-43
 - hold, 4-22
 - transfer, 4-24
- Recall tones, 4-14
- Recommended spare parts, 7-1
- Redialing, 4-33
 - capacity, 1-3
 - troubleshooting, 6-5
- Repeater applications, 2-12
- Replacement parts
 - ordering, 7-1
 - recommended spares, 7-1
- Return policy, 6-19
- Reverse transfer, 4-24
- RFI/EMI, troubleshooting, 6-18
- Ring cadence, 4-12, 5-14
- Ring intercom first, 5-12, 5-13
- Ring tone selection, 4-8
- Ring-in assignment, 4-4, 5-12, 5-13
- RJ14 jacks, 2-2, 3-12
- RJ21X block, 2-2, 3-14
- RUN LED, 6-1

S

- Safety regulations, ix, 3-4
- Selectable ring tone, 4-8
- Signalling devices, 2-10
- Signals and tones, 4-14
- Single-line maximum/minimum hookflash timer, 5-15
- Single-line port dB padding, 4-12, 5-15
- Single-line port initialization, 5-6, 5-7
- Single-line station, 2-11, 4-12
 - cabling, 3-5
 - call waiting tones, 4-12
 - capacity, 2-9
 - features, 1-3
 - hookflash, 4-16
 - hookflash timers, 4-12, 5-15
 - installation, 3-31
 - port dB padding, 4-12
 - programming, 4-12, 5-13
 - ring cadence, 4-12
 - troubleshooting, 6-4, 6-14, 6-15
- SMDR Adapter, 2-13
- SMDR device station, 4-35
- Speakerphone, 2-9, 4-6
 - enable/disable, 5-12, 5-13
 - troubleshooting, 6-11
- Speed dialing
 - database report, 4-38, 4-42
 - SCC number, 4-33
 - station, 4-32
 - system, 4-32
 - toll restriction override, 4-32, 5-9, 5-11
 - troubleshooting, 6-5
- Speed-dial pause timer, 5-9, 5-11
- Standby power supply (SPS), 2-12, 3-33
- Station features
 - program planning, 5-4
 - programming, 5-8, 5-12
- Station message detail recording (SMDR), 4-35
 - clock adjustment, 4-36
 - database report, 4-38, 4-39
 - date, 4-36
 - device, 2-13
 - print conditions, 4-35
 - programming, 4-35
 - report sample, 4-37
 - time, 4-35
 - valid call timer, 4-36
- Station options, 5-12, 5-13
- Station programming report, 4-38, 4-41
- Station speed dialing, 4-32
 - capacity, 1-3
 - locations, 4-32
- Stations, 2-9
 - cabling, 2-2, 3-5, 3-6, 3-7
 - loop limits, 3-11
 - connection to MDF, 3-8, 3-9, 3-10
 - installation, 3-22
 - signals and tones, 4-14
 - station instruments, 2-1, 4-6
 - toll restriction, 4-4
 - troubleshooting, 6-16
- Surge/spike protector, 2-5
- System battery back-up, 2-12, 4-5
 - installation, 3-33
- System features, 1-2
 - initializing, 5-6
 - program planning, 5-2
 - programming, 5-8
 - troubleshooting, 6-3
- System hardware troubleshooting, 6-4
- System hold, 4-22
- System initialization, 5-6
- System options
 - program planning, 5-3
 - programming, 5-9, 5-11
- System power supply, 2-5
 - isolated, dedicated circuit, 2-5
 - surge/spike protector, 2-5
- System programming report, 4-38, 4-40
- System software initialization, 5-6
- System speed dialing, 4-32
 - capacity, 1-3
 - override toll restriction, 4-5
 - programming, 4-44
- System timers
 - program planning, 5-2
 - programming, 5-8

T

Technical support, 6-19

Temperature, 2-3, 3-4

Time

GLX-Plus, 4-34

SMDR, 4-35

Timers

program planning, 5-2

programming, 5-8

Toll restriction, 4-4

basic, 4-5

excluding lines, 4-5, 5-9, 5-11

programming, 5-9, 5-11, 5-12, 5-13

speed dial override, 4-5, 4-32, 5-9, 5-11

Tones, 4-14

Tool and supplies, 3-4

Transfer, 4-24

from voice mail, 4-13

recalls, 4-24

reverse, 4-24

to voice mail, 4-13

Troubleshooting

charts, 6-3-6-18

checklist, 6-1

LEDs, 6-1

U

Uninterruptable power supply (UPS), 2-12, 3-33, 4-5

V

Valid call timer, 4-36

Voice mail, 2-12, 4-12

forward to, 4-13

transfer from, 4-13

transfer to, 4-13

Volume controls, 4-9

W

Warranty, x

GLX and GLX-Plus Version 3.1 System Software Upgrade Instructions

Part Number 827.8464

INTRODUCTION

NOTICE

To use these upgrade instructions, the Main Control PCB in the KSU must be equipped with socket UB2 and jumper J20. If it is not, contact Inter-Tel Customer Support to return the KSU so it can be modified with ECN-3518.

This document contains instructions on upgrading existing GLX and GLX-Plus System systems with the new enhanced version 3.1 software — part number 827.8464. This software is compatible with the 1995 North American Numbering Plan (NANP) changes.

The single existing software EPROM located on the Main Control PCB of the KSU must be replaced with the two new EPROMs included with these instructions.

NOTE: Since the database back-up battery must be disabled to install the new software, the existing database cannot be saved. After installing the new software, the database must be initialized and the system reprogrammed.

For complete information on new system features, refer to Issue 2 of the *GLX-Plus Installation and Field Maintenance Manual* and its new addendum (part no. 612.8017).

INSTALLATION INSTRUCTIONS

CAUTION: *The boards and components are static sensitive. Handle the boards by the edges only and keep replacement components in their protective case until they are to be installed. Do not bend or touch the pins of the components or subject them to a static charge. When working with the boards, use an anti-static wrist strap and cover the work surface with the anti-static bag that protected the board during shipping. Any static charge (no matter how small the charge) must be discharged from the body before touching the boards or components. The warranty for this equipment does not cover damage caused by static or mishandling. Boards or components damaged in such a manner will not be replaced.*

To replace the existing software EPROM with the two new software EPROMs, follow these steps:

1. Check the part number and socket location on the labels of the new software components. They should be labeled with part number 827.8464 and socket locations UB2 and UB4.
2. *If the software components are to be installed on an active system, turn OFF the PWR switch on the KSU. Then remove the KSU from the MDF backboard.*

3. Place the KSU on a flat surface with the cover facing up. Open the cover by removing the retaining screws and lifting off the cover.
4. Locate the database back-up battery (BAT1) on the Main Control PCB. Insert a piece of paper between the battery and the clip to open (break) the contact and disable the battery.
5. Carefully remove the existing software component from socket UB4. Set the component aside.
6. Carefully install the new software components in sockets UB2 and UB4. The notch (or small dot in the corner indicating pin 1) on each component must match the notch of the outline that is silkscreened on the board.
7. Check to see that all components are seated securely in their sockets and that no pins are bent.
8. Move jumper strap J20 (located above integrated circuit UC1) from the HG position to the IH position.
9. Re-enable the database back-up battery by removing the piece of paper inserted in step 4.
10. Put the cover back on the KSU and re-insert the retaining screws.
11. *If the KSU was previously installed, place the KSU back on the MDF backboard and turn ON the PWR switch.*
12. Initialize the database and reprogram the system as outlined in the system installation manual.

NOTE: For complete installation and programming information, refer to Issue 2 of the *GLX-Plus Installation and Field Maintenance Manual* and its new addendum (part no. 612.8017).

13. **To receive a credit, return the removed EPROM to Inter-Tel:** Place the old software component in the plastic container that housed the new components, and package the container for shipment. Write the AR Authorization Number on the outside of the shipping box and return it to:

Inter-Tel Integrated Systems, Inc.
7300 W. Boston St.
Chandler, AZ 85226-3224

NOTICE: *It is a violation of copyright laws to reproduce the enclosed software media without prior written approval from Inter-Tel Integrated Systems, Inc. Any attempt to produce unauthorized duplicates will result in criminal prosecution.*



ADDENDUM TO ISSUE 2 OF THE GLX-PLUS MANUAL

For Software Part Number: 827.8171 (3.0) and 827.8464 (3.1)

This addendum describes feature and programming changes that apply when the GLX-Plus System is installed with the software part number listed above. It also includes changes and corrections to Issue 2 of the *GLX-Plus Installation and Field Maintenance Manual*. For software installation instructions, refer to the document included with the software components. The new system software is identical to the previous version of GLX-Plus software, except for the changes and corrections described on these pages. Refer to the manual for detailed system information.

FEATURE AND PROGRAMMING CHANGES

The current GLX-Plus software releases (part numbers 827.8171 [3.0] and 827.8464 [3.1]) are enhanced with features for flexible toll restriction based on the new North American Numbering Plan (NANP). They provide methods for programming area and office codes, and include toll restriction changes to support the new NANP. In addition, the 827.8464 (3.1) software version supports absorbed digits for enhanced toll restriction and includes an End-of-Dialing timer.

This addendum includes information about the following topics:

- Numbering Plan Flags
- Home and Extended Area Codes
- Allowed and Restricted Area Codes
- Allowed and Restricted Office Codes
- Absorbed Digits (*software version 3.1 only*)
- Database Programming Report
- System Option 1 Operation Changed To Support NANP
- System Option 2 Applied Only To Home and Local Extended Area Codes
- System Option 3 Changed To Restrict Directory-Assistance Calls
- New System Option 8 — Restrict 011+ International Calls
- Programmable End-Of-Dialing Timer (*software version 3.1 only*)

Numbering Plan Flags

The growth of telecommunications services has created an increasing demand for more telephone numbers. To meet the demand, Bellcore has prepared a long-range North American Numbering Plan (NANP) to provide additional telephone numbers. The plan expands the capacity of the current numbering system by making area and office codes interchangeable. That is, numbering patterns formerly reserved for office codes can be used as new area codes, and office codes within existing area codes can have the same pattern as other area codes.

With interchangeable codes, telephone systems lose the ability to distinguish between 7- and 10-digit numbers by examining the first three digits.

The former numbering plan required an area code to be in the "NZX" format, where N=2-9, Z=0 or 1, and X=0-9. The new numbering plan allows the area code format "NXX," which is the current office code format. Therefore, with the new numbering plan, more area and office codes will overlap.

In order to properly process the new telephone numbers, four flags have been added to the system database. They are as follows:

- **Office Codes Used as Area Codes:** An area code in another location uses an NXX pattern that matches an office code within the system site's area code. (This flag defaults to *no*.)
- **Area Codes Used as Office Codes:** One or more office codes within the system site's area code use an NZX pattern that is the same as an area code in another area. (This flag defaults to *no*.)
- **Toll Digit Allowed On Toll Calls:** This option applies only if the area and office codes overlap. Callers in the site's area code usually dial a 0 or 1 when placing a 7-digit toll call within the local area code(s). (This flag defaults to *no*.)
- **Toll Digit Required On Toll Long Distance Calls:** This option applies only if the area and office codes overlap. Callers in the site's area code must dial a 0 or 1 when placing a 10-digit toll call outside of the local area code(s). (This flag defaults to *no*.)



The following chart illustrates the difference between the overlap flags. In the chart, N=2-9, Z=0 or 1, and X=0-9.

	AREA CODES CAN BE:	OFFICE CODES CAN BE:
Office Codes as Area Codes	NZX or NXX	NXX
Area Codes as Office Codes	NZX	NXX or NZX

The area/office code flags must be set properly on the system in order for toll restriction to work correctly for the given site. The system must know whether the area and office codes overlap, and whether toll digits will be dialed, to properly apply toll restriction. For example, if you have the system programmed to look for a toll digit (0 or 1) on toll long distance calls on a system where area and office codes overlap, and the station user placing a call does not dial the 1 (dials 213-555-1234 instead of 1-213-555-1234), the system may allow the call (depending on the NANP flag settings) as if the user was dialing a local non-toll call. However, if the station user dials 1-213-555-1234, the call will be restricted as usual after the digits are dialed.

The Numbering Plan Flags information is programmed as follows. Refer to the program planning sheet on page 6. All flags are disabled when the system is in the default state.

- (1) Make sure the KSU PWR and PRG EN switches are ON.
 - (2) While on hook at the attendant's station (intercom 10), press the SPD key and dial 031.
 - (3) Press 1 to enable, or 0 to disable, the "Office Codes Used As Area Codes" flag.
 - (4) Press 1 to enable, or 0 to disable the, "Area Codes Used As Office Codes" flag.
 - (5) Press 1 to enable, or 0 to disable, the "Toll Digit Allowed On Toll Calls" flag.
 - (6) Press 1 to enable, or 0 to disable, the "Toll Digit Required On Toll Long Distance Calls" flag.
- Example:** If you enter 0110, you will disable the first flag, enable the second and third, and disable the fourth.
- (7) Lift and replace the handset. You hear a confirmation tone.

Home And Local/Non-Local Extended Area Codes

In many areas, the telephone company has created call-cost arrangements that refer to "home," "local," and "non-local" area codes. The Home Area Code is the area code within which the system resides. The "local" Extended Area Codes are additional area codes that the telephone company considers local or toll local calls from the Home Area Code. Calls placed to "non-local" Extended Area Codes from the Home Area Code are considered long distance by the telephone company.

One Home Area Code and two Extended Area Codes (local or non-local) can be programmed. Office codes can be designated as allowed or restricted within the two Extended Area Codes (by default, they are all restricted). All office codes within the Home Area Code are allowed.

NOTE: If you wish to designate office codes as allowed or restricted within your Home Area Code, or if the Home Area Code must be dialed to place a toll call within the area code, enter it as both the Home Area Code and as a local Extended Area Codes. Then allow or restrict the office codes as described on the next page.

The Home Area Code and/or local and non-local Extended Area Codes information is programmed as follows. Refer to the program planning sheet on page 6. If you make a mistake during programming, press an invalid key or allow the programming request to timeout to exit without changing the database.

- (1) While on hook at the attendant's station (intercom 10), press the SPDL key and dial 032.
- (2) Enter the three-digit Home Area Code.
- (3) If needed, program the Extended Area Code(s) as follows:

- a. Press asterisk (*) for local Extended Area Code or pound (#) for non-local Extended Area Code.
- b. Enter the three-digit area code for the Extended Area Code 1.
- c. If necessary, you can enter * or # and the three-digit area code for the Extended Area Code 2.

Example 1: The Home Area Code is 602 and certain office codes within the 602 area code are considered local numbers. Area code 415 is an extended local area code. Certain office codes within the 415 area code are considered local numbers, when dialed from the 602 area code. The programming is as follows: SPDL 032 602 * 602 * 415.

Example 2: The home area code is 602. The extended area codes are 404 and 216. Certain office codes will be allowed in the 404 and 216 area codes. All office codes will be allowed in the 602 area code. The programming is as follows: SPDL 032 602 # 404 # 216.

- (4) Lift and replace the handset. You hear a confirmation tone. If you programmed Extended Area Codes, refer to the instructions on the next page for allowing and restricting office codes.

NOTE: If you changed an Extended Area Code to a new area code, the office code programming for the previous area code remains unchanged until you reprogram it. That is, if you change Extended Area Code 1 from 303 to 406, the office code programming for 303 will remain in effect until you reprogram the office codes for Extended Area Code 1 using feature code 034.

Allowed And Restricted Area Codes

NOTE: This method can be used to restrict calls to 900 and 976 numbers. However, 911 and 1911 calls cannot be restricted.

You can allow or restrict specific area codes. Restricting an area code prevents users from placing calls to that area code. Allowing an area code allows users to place calls to all office codes within that area code. (To restrict specific office codes within an area code, use the Extended Area Code programming procedure described on this page and the Allowed And Restricted Office Codes information on the next page.)

By default, all of the area codes, except Home and Extended Area Codes, are restricted. The Home and Extended Area Codes are automatically allowed and do not have to be programmed using this procedure. However, if you remove an area code from the Home/Extended list, it remains as an allowed area code and all of its office codes become allowed. You must use this procedure if you want to restrict it.

The Allowed and Restricted Area Codes information is programmed as follows. Refer to the program planning sheet on page 6. If you make a mistake during programming, press an invalid key or allow the programming request to timeout to exit without changing the database.

- (1) While on hook at the attendant's station (intercom 10), press the SPDL key and dial 033.
- (2) *To Allow All Area Codes:* Press asterisk (*) and then the SPDL key.
- (3) *To Restrict All Area Codes:* Press pound (#) and then the SPDL key. **NOTE:** If you restrict all area codes, be sure to allow the Home Area Code and Extended Area Codes as described in step 4, below.
- (4) *To Allow A Specific Area Code:* Press asterisk (*) and then the three-digit area code.
- (5) *To Restrict A Specific Area Code:* Press pound (#) and then the three-digit area code.
- (6) Repeat steps 4 and 5 as needed until all area codes are programmed as desired.

Example: If you want to restrict all area codes except 602, 818, 213, and 415, enter # SPDL * 602 * 818 * 213 * 415 (“# SPDL” to restrict all, “*602” to allow 602, “*818” to allow 818, “*213” to allow 213, and “*415” to allow 415).

- (7) Lift and replace the handset to store your changes. (They are not stored until you complete this step.) You hear a confirmation tone.

Allowed And Restricted Office Codes

NOTE: This method can be used to restrict calls to 900 and 976 numbers. However, 911 and 1911 calls cannot be restricted.

The Extended Area Codes can be programmed to allow or restrict specific office codes within them. The code for programming office codes for Extended Area Code 1 is 034. The code for Extended Area Code 2 is 035. In the default state, all office codes in both area codes are restricted.

NOTE: If you changed an Extended Area Code to a new area code, the office code programming for the previous area code remains unchanged until you reprogram it. That is, if you change Extended Area Code 1 from 303 to 406, the office code programming for 303 will remain in effect until you reprogram the office codes for Extended Area Code 1 using feature code 034.

The Allowed and Restricted Office Codes information is programmed as follows. Refer to the program planning sheet on page 6. If you make a mistake during programming, press an invalid key or allow the programming request to timeout to exit without changing the database.

- (1) While on hook at the attendant's station (intercom 10), press the SPDL key then enter 034 to program office codes for Extended Area Code 1 or enter 035 to program office codes for Extended Area Code 2.
- (2) *To Allow All Office Codes:* Press asterisk (*) and then SPDL.
- (3) *To Restrict All Office Codes:* Press pound (#) and then SPDL.
- (4) *To Allow A Specific Office Code:* Press asterisk (*) and then the three-digit office code.
- (5) *To Restrict A Specific Office Code:* Press pound (#) and then the three-digit office code.
- (6) Repeat steps 4 and 5 as needed until all office codes are programmed as desired.

Example: If you want to restrict all office codes except 961 and 893, enter # SPDL * 961 * 893 (“#SPDL” to restrict all, “*961” to allow 961, and “*893” to allow 893).

- (7) Lift and replace the handset to store your changes. (They are not stored until you complete this step.) You hear a confirmation tone.

Absorbed Digits

CO lines can be programmed to “absorb” or ignore the first digit(s) dialed so that only the remaining digits are checked for toll restriction and call cost purposes. There are two applications for this feature: PBX installations and installations in areas where part of the local office code is absorbed by the central office.

If a caller select a line and dials the absorbed digits, those digits will be absorbed (ignored) by the system. Each CO line can have one programmed absorbed digit string of up to 7 digits.

To program an absorbed digit string, follow these steps:

- (1) While on hook at the attendant’s station (intercom 10), press the SPDL key and dial 036.
- (2) Dial the number of the CO line to be programmed (1–6).

- (3) Dial the absorbed digit string (up to 7 digits).
- (4) Lift and replace the handset to save the changes. (Or to cancel the change, press any CO line key.)
- (5) Repeat these steps for each CO line to be programmed.

To erase an absorbed digit string, follow these steps:

- (1) While on hook at the attendant’s station (intercom 10), press the SPDL key and dial 036.
- (2) Dial the number of the CO line to be programmed (1–6).
- (3) Lift and replace the handset to erase the absorbed digit string. (Or to leave the absorbed digit string unchanged, press any CO line key.)
- (4) Repeat these steps for each absorbed digit string to be erased.

PROGRAM PLANNING SHEET

Numbering Plan Flags (SPDL 031)

Place a check mark in the appropriate box to indicate whether the flag should be enabled or disabled.

FLAG	ENABLED (1)	DISABLED (2)
Office Codes Used As Area Codes		
Area Codes Used As Office Codes		
Toll Digit Allowed On Toll Calls		
Toll Digit Required On Toll Long Distance Calls		

Home And Extended Area Codes (SPDL 032)

Home Area Code	
----------------	--

	LOCAL (*) OR NON-LOCAL (#)	AREA CODE
Extended Area Code #1		
Extended Area Code #2		

Allowed And Restricted Area Codes (SPDL 033)

Allowed Area Codes	
Restricted Area Codes	

Allowed And Restricted Office Codes (SPDL 034 & SPDL 035)

EXTENDED AREA CODE #1 (SPDL 034)	
Allowed Office Codes	
Restricted Office Codes	

EXTENDED AREA CODE #2 (SPDL 035)	
Allowed Office Codes	
Restricted Office Codes	

Absorbed Digit Strings (SPDL 036)

ABSORBED DIGIT STRINGS					
Line 1	Line 2	Line 3	Line 4	Line 5	Line 6

Database Programming Report

A database report can be generated at the SMDR device station and printed to show a summary of database programming, as described on page 4-38 of the manual.

When you generate a System Report or a Programming Report, it will show the status of the flags and the Home Area Code and Extended Area Codes. (The report will

not include the lists of allowed and restricted area and office codes.) The report is shown below.

Database reports can be recorded on a customer-provided printer or an alternate device, such as a personal computer or floppy disk. This output device is connected to the optional GLX-Plus SMDR Adapter which is connected to the SMDR station's keyset.

DATABASE REPORT FORMAT

Inter-Tel GLX-12

Database Report - System Features

System Timers:

Attendant Recall	* 1 1	XXX Sec.
Hold Recall	* 1 2	XXX Sec.
Inactivity	* 1 3	XX Sec.
Call Forward Duration	* 1 4	XXX Sec.
Call Forward Warning	* 1 5	XXX Sec.
Call Forward No Answer	* 1 6	XX Sec.

Feature Timers:

C.O. Flash	* 2 1	X.X Sec.
C.O. Delay	* 2 2	X.X Sec.
Speed-Dial Pause	* 2 4	X.X Sec.
Memory-Dial Speed	* 2 5	X.X Sec.
C.O. Ring Duration	* 2 7	X.X Sec.
Abandoned Call	* 2 8	XX.X Sec.

Miscellaneous Timers:

Make/Break Ratio	* 3 1	XX %
Pulse-Dial Speed	* 3 2	0.X Sec.
Pulse-Dial Interdigit	* 3 3	0.X Sec.

Lines Not Subject to

Toll Restriction	#4:	X,X,X,X,X,X
------------------	-----	-------------

System Options

	#5:	X,X,X,X,X,X,X,X
--	-----	-----------------

Call Forward to Public Network Line

	#6:	X
--	-----	---

Call Forward, DIL Diversion Lines

	#7:	X,X,X,X,X,X
--	-----	-------------

Pulse-Dialing Lines

	#8:	X,X,X,X,X,X
--	-----	-------------

Night Security Code

	#9:	XXXX
--	-----	------

Toll Restrict Flags:

Office Codes Used As Area Codes:	N
Area Codes Used As Office Codes:	N
CO Allows 1 on 7-Digit Calls:	N
CO Allows 1 on 10-Digit Calls:	N

Home Area Code :	XXX (local)
------------------	-------------

Extended Area Code #1:	XXX (local)
------------------------	-------------

Extended Area Code #2:	XXX (non-local)
------------------------	-----------------

System Option 1 Operation Changed To Support NANP

System Option 1 (restrict calls that begin with 0 or 1) operates differently, now that the numbering plan flags and the area/office code programming affect toll restriction. If the NANP flags are set correctly for the GLX-Plus site, the following will occur when System Option 1 is enabled:

- When the caller dials 1, plus an allowed area code and office code, the call is *allowed*.
- When the caller dials 1, plus an allowed office code within the Home Area Code or an Extended Area Code, the call is *allowed*.
- When the caller dials 1, plus a Home/Extended Area Code and a restricted office code, the call is *restricted*.
- When the caller dials 0, plus any allowed or restricted area code or office code, the call is *restricted*.

System Option 2 Applied Only To Home And Local Extended Area Codes

System Option 2 restricts calls that begin with 0 or 1 and calls that have more than eight digits. This System Option is applied only to calls that use the Home Area Code or *local* Extended Area Codes.

System Option 3 Changed To Restrict Directory-Assistance Calls And Support NANP

System Option 3, described on page 5–9 of the manual has been changed. Previously, it restricted calls with 0 or 1 as first digit, or more than eight digits long, but allowed 1411, 1911, and numbers beginning with 1–555, 1–XXX–555, 800, and 1–800. It now does the following:

Option 3 — Restrict calls to 411, 1411, 1–555–XXXX and 1–XXX–555–XXXX: This prevents directory-assistance calls from being placed. It allows calls with more than eight digits when an allowed area code and office code are dialed.

New System Option 8 - Restrict 011+ International Calls

A new System Option has been added to restrict international calls that begin with 011. This option is used sepa-

rately from System Options 1–3. If System Options 1–3 are enabled, all 0+ calls, including 011+ calls are restricted.

End-Of-Dialing Timer (software version 3.1 only)

The End-Of-Dialing timer is a new system-wide timer. It determines the amount of time a user is allowed for dialing a valid number, before toll restriction is checked. When a CO line is seized and the first digit is dialed, the timer is activated. When the timer expires, any applicable toll restriction is applied to the dialed number.

The default value of the timer is 15 seconds. The range is 1–25 seconds.

Lengthening the timer allows the GLX-Plus system to wait longer for additional digits, thus delaying the check for toll restriction. Shortening the timer causes the GLX-Plus to check the number for toll restriction sooner.

Example: The customer dials part of a local number and pauses before entering the last few digits. If the customer pauses longer than the End-of-Dialing timer, the system will drop the call. In this case, the programmer could lengthen the End-of-Dialing timer to allow longer pauses between digits and to delay the toll restriction check.

In most cases, you will not need to reprogram the End-of-Dialing timer. However, if the customer experiences difficulties restricting 7-digit toll calls or pager numbers, the timer can be adjusted.

To program the End-of-Dialing timer, do the following:

- (1) Make sure the KSU PWR switch and the PRG EN switches are ON.
- (2) While on hook at the attendant's station (intercom 10), press the SPDL key. The display shows PROG SPDL.
- (3) Enter 037.
- (4) Enter the time for the End-of-Dialing timer (01–25).
- (5) Lift and replace the handset to save your changes. You hear a confirmation tone.

CHANGES AND CORRECTIONS TO ISSUE 2

Please note the following changes and corrections to Issue 2 of the *GLX-Plus Installation and Field Maintenance Manual*.

Page 2-10, paragraph 4.14: The first sentence should read as follows:

The Executive Keyset has a *two*-conductor modular jack...

Page 2-13, section F: The optional SMDR Adapter (sold by Integrated Design Services) has been discontinued and is no longer available.

Page 4-10, paragraph 5.25: The first sentence should read as follows:

The Executive Keysets have a *two*-conductor modular jack...

Page 4-24, paragraph 12.3, step 3: The first sentence should read as follows:

If *your* intercom call is answered, announce the call and hang up.

Page 4-35, paragraph 23.5: The numbers associated with the SMDR print conditions are as follows:

- All incoming calls — 1
- All outgoing calls — 2
- Only outgoing toll calls (8 or more digits) — 3

Page 5-6, paragraph 4.4: Add the following sentence:

The KSU PRG EN switch must be in the ON position to allow APM initialization.

Page 5-7, paragraph 4.7, step 2: The “2” on third line is part of the dialing sequence (i.e., dial # 0 1 2).

Page 5-7, paragraph 4.8, step 3: Step 3 should be as follows. Substeps c and d were removed.

- (3) **Initialize the APM single-line ports:**
- a. At the single-line set that is connected to APM port 1, lift the handset.
 - b. When you hear dial tone, dial # 3 and hang up until the DSS key for APM port 1 is unlit (approximately 15 seconds). This sets the station options to default values.
 - c. Repeat this procedure using the single-line set connected to APM port 2.

Page 5-13, paragraph 5.8: Remove the words *or DISA* from the second sentence.

Page 5-15, paragraph 5.26, step 2: The step is incorrect. The correct information is as follows:

- (2) Dial # 2 3 to *disable* dB padding or dial # 1 3 to *enable* dB padding. You will hear a confirmation tone.

Page 7-1, Figure 7-1, under Station Instruments: The current part numbers for the Standard and Executive Keysets are:

Standard Keyset	612.3201
Executive Keyset	612.3301

Page 7-1, Figure 7-1, under Miscellaneous Equipment: Add the following part number:

GLX-Plus Keyset Battery Back-Up Connection Kit	828.1239
---	----------