



Key Voice®  
Voice Processing

---

# DEBUT AND LITE SYSTEM INSTALLATION AND SUPERVISOR GUIDE



KEY VOICE®  
Everything Your Business Calls For

# NOTICE

NOTICE TO END USER: CAREFULLY READ THE FOLLOWING TERMS AND CONDITIONS. USE OF THE SOFTWARE CONTAINED IN THIS PACKAGE CONSTITUTES YOUR ACCEPTANCE OF THESE TERMS AND CONDITIONS AND AGREEMENT TO ABIDE BY THEM.

If you do not agree with the terms and conditions of this Agreement, return the package and its entire contents to the location where you obtained it for a refund.

In return for acquiring a license to use the Key Voice Technologies Inc. software and documentation contained in this package ("the Software"), and for acquiring the accompanying documentation, you, the original purchaser ("You"), agree as follows:

1. License Grant: You are granted a nonexclusive, personal license to: (a) use the Software on a single personal computer system (b) copy the Software solely for the purpose of installing it on your computer and for backup and archival storage. You may not transfer, sell, lease or distribute copies of the Software to others. You may assign your rights under this Agreement to a third party provided the third party agrees in writing to be bound to the terms of this Agreement and you transfer all copies of the Software to the third party or destroy any copies not transferred. Any other attempt to sublicense, assign or transfer any of the rights, duties or obligations hereunder is void.
2. No Other Rights: You acknowledge that the Software is copyrighted and is proprietary. The license granted above is not a sale of the Software, and except as stated above, this Agreement does not give you any rights to patent, copyright, trade secrets, trademarks or any other rights or licenses with respect to the Software. You agree to hold the Software in confidence and to take reasonable steps to prevent unauthorized copying or distribution.
3. No Modification or Reverse Compilation: YOU MAY NOT MODIFY, ALTER, TRANSLATE, DISASSEMBLE OR DECOMPILE THE SOFTWARE OR DOCUMENTATION OR ANY COPY, IN WHOLE OR IN PART.
4. Limited Warranty: Key Voice Technologies, Inc. warrants that the original diskettes are free from defects in material and workmanship, assuming normal use, for a period of ninety (90) days from the date of purchase. If a defect occurs during this period, you may return your faulty disk along with a dated proof of purchase; it will be replaced free of charge.

EXCEPT FOR THE EXPRESS WARRANTY OF THE ORIGINAL DISKETTES SET FORTH ABOVE, NO OTHER WARRANTIES ARE GRANTED, EXPRESS OR IMPLIED, BY STATUTE OR OTHERWISE, REGARDING THE DISKS AND RELATED MATERIALS, THEIR FITNESS FOR ANY PURPOSE, THEIR QUALITY, THEIR MERCHANTABILITY, OR BOTH.

THE LIABILITY UNDER THE WARRANTY SET FORTH ABOVE SHALL BE LIMITED TO THE AMOUNT PAID BY THE CUSTOMER FOR THE PRODUCT. IN NO EVENT SHALL THE MANUFACTURER OR DISTRIBUTORS BE LIABLE FOR ANY SPECIAL, CONSEQUENTIAL, OR OTHER DAMAGES FOR BREACH OF WARRANTY.

Information in product documentation is subject to change without notice, and does not represent a commitment on the part of Key Voice Technologies Inc. No part of Key Voice manuals may be reproduced or transmitted in any form or by any means, electronic or mechanical, including photocopying, for any purpose other than the purchaser's personal use, without the written permission of Key Voice Technologies, Inc. Products mentioned in this documentation that are not manufactured by Key Voice Technologies, Inc. may be trademarks or registered trademarks of their respective manufacturers.

© Copyright Key Voice Technologies, Inc., 1991-1998.  
All rights reserved.

## LIMITED WARRANTY

The initial hardware and software of all Key Voice Technologies, Inc. (“Key Voice”) products accompanying this installation manual shall be referred to collectively herein as the “Product”. Non-Key Voice products are warranted solely by the manufacturer in accordance with the manufacturer’s warranty, and are sold by Key Voice “as is”. Key Voice warrants, to its purchaser, its authorized dealers and the end users of the Product, that, under normal operating conditions, (a) the Product hardware (except for fuses, lamps and other consumables) and the medium on which the Product software is contained will be free from defects in material and workmanship, and (b) the Product software will perform substantially in accordance with the specifications set out in the user guide accompanying the Product which is prepared by Key Voice, in each case for a period of one year, measured from the manufacturing date stamped on the Product hardware or software, as the case may be, provided however, development products, i.e., products which have not yet been approved by Key Voice for production, are sold pursuant to Key Voice’s field trial agreement and are warranted as set out therein. Key Voice’s sole obligation under this warranty or under any other legal obligation with respect to the Product is to repair or replace, at its option, the Product at its Sarasota, Florida, headquarters, free of charge, if the Product is deemed defective by Key Voice during the warranty period, with refurbished or new equipment or parts, at Key Voice’s option, when the Product is returned to Key Voice, freight or postage prepaid, during the warranty period, provided however, if Key Voice is not able, using reasonable efforts, to cure or correct a defect, Key Voice’s sole obligation shall then be to refund (or cause to be refunded) an equitable portion of the price Key Voice was paid for the Product. This warranty does not apply if, in the sole judgment of Key Voice, the Product, or any part(s) or component(s) thereof, have been improperly installed or installed or used in combination or in assembly with hardware or software not supplied by Key Voice and which are not compatible with the Product or which are of inferior quality, design or performance, or the Product, or any part(s) or component(s) thereof, have been improperly handled, misused, abused, altered, tampered with, accidentally damaged, or damaged or malfunction or fail to function due to neglect, negligence, contamination (by liquid or otherwise) or as a result of any other causes beyond Key Voice’s reasonable control, including extraordinary wear and tear and acts of God such as fire, flood, water, or lightning or other incidence of excessive or insufficient voltage or failure to follow instructions. Repair, wiring, or alteration of the Product other than as specifically authorized by Key Voice or its authorized repair agent is prohibited and will void this warranty. This warranty does not cover costs associated with installation, removal, or reinstallation of the Product. Key Voice does not warrant that the Product is compatible with all telephone or switching systems or that the Product is invulnerable or immune from unauthorized or fraudulent use, or unaccounted for access to the Product. **THIS WARRANTY IS EXCLUSIVE, BEING IN LIEU OF ALL OTHER WARRANTIES EXPRESS OR IMPLIED, INCLUDING, BUT NOT LIMITED TO, ANY IMPLIED WARRANTY OF MERCHANTABILITY OR FITNESS FOR A PARTICULAR PURPOSE.**

## LIMITATION OF LIABILITY

WITHOUT EXPANDING UPON THE FOREGOING WARRANTY, THE MAXIMUM LIABILITY OF KEY VOICE UNDER ANY WARRANTY, STATUTORY, EXPRESS OR IMPLIED, IS LIMITED TO THE PURCHASE PRICE OF THE PRODUCT. KEY VOICE SHALL HAVE NO RESPONSIBILITY FOR DAMAGE TO PROPERTY OR ANY OTHER LOSS OR INJURY, INCLUDING CONSEQUENTIAL, INCIDENTAL, OR INDIRECT DAMAGES, SUCH AS LOSS OF PROFITS OR LOSS OF BUSINESS INFORMATION, DAMAGES DUE TO BUSINESS INTERRUPTION OR ANY OTHER PECUNIARY LOSS, EVEN IF KEY VOICE HAS BEEN ADVISED OF THE POSSIBILITY OF SUCH DAMAGES, OR PUNITIVE DAMAGES, RESULTING FROM THE PURCHASE, POSSESSION, INSTALLATION, OPERATION, REPAIR, USE OF PURCHASE, POSSESSION, INSTALLATION, OPERATION, REPAIR, USE OF OR INABILITY TO USE, THE PRODUCT, OR THE UNAUTHORIZED OR THE FRAUDULENT USE OF, OR UNACCOUNTED FOR ACCESS TO, THE PRODUCT, ALL SUCH CLAIMS BEING HEREBY EXPRESSLY WAIVED. THE PURCHASER'S EXCLUSIVE WARRANTY AND REMEDY SHALL BE ONLY AS STATED HEREIN.

This warranty gives you specific legal rights and you may also have other rights which may vary from state to state. Some states do not allow limitation on how long an implied warranty lasts or the exclusion or limitation of incidental or consequential damages, so the above limitations may not apply to you. If the Magnuson Moss Act should be held to apply to the sale of the Product by a court of competent jurisdiction, the implied warranty of fitness for a particular purpose shall extend for one year from the date of manufacture. No Key Voice dealer nor any other person or entity other than Key Voice may extend or modify this warranty, and no such modification or extension shall be effective unless it is in writing.

# Table of Contents

|   |          |
|---|----------|
| <b>1. System Overview .....</b>                                   | <b>1</b> |
| 1.1 What Does the Lite System Do?.....                            | 1        |
| 1.1.1 What is an Automated Attendant?.....                        | 1        |
| 1.1.2 What is Voice Mail?.....                                    | 2        |
| 1.2 Understanding the Lite System Product Design.....             | 3        |
| <b>2. System Setup Instructions .....</b>                         | <b>5</b> |
| 2.1 Available System Setup Techniques .....                       | 5        |
| 2.2 Preparing for System Setup.....                               | 6        |
| 2.3 Connecting the Lite System Unit to the Telephone System ..... | 8        |
| 2.3.1 Connecting Directly to the Central Office (C.O.) .....      | 8        |
| 2.3.2 Connecting the Lite System to a PBX or Key System .....     | 9        |
| 2.4 Collecting Necessary Customer Information.....                | 11       |
| 2.5 Setting Up the System by Attaching a Laptop.....              | 21       |
| 2.5.1 Installing KeyLink Software onto the Laptop.....            | 21       |
| 2.5.2 Connecting the Laptop to the Lite System Unit.....          | 21       |
| 2.5.3 Completing the First Time Setup Procedure .....             | 23       |
| 2.5.4 Running the PBX Setup Utility from Install Program.....     | 23       |
| 2.5.5 Specifying System Information.....                          | 25       |
| 2.5.5.1 Integration Defaults Set by the Integration Program.....  | 25       |
| 2.5.5.2 Using Technical Bulletin Information.....                 | 28       |
| 2.5.5.3 Accessing System Information Screens .....                | 28       |
| 2.5.5.4 Setting Up the General Information Screen .....           | 29       |
| 2.5.5.5 Setting Up the Line Information Screen.....               | 29       |
| 2.5.5.6 Setting Up the Business Hours Screen .....                | 30       |
| 2.5.5.7 Setting Up the Call Transfer Screen.....                  | 30       |
| 2.5.5.8 Setting Up the Class of Service Screen .....              | 30       |
| 2.5.6 Specifying Box Information.....                             | 38       |
| 2.5.6.1 What Is a Box? .....                                      | 38       |
| 2.5.6.2 Understanding Routing Box 800, 801, and 821 .....         | 38       |
| 2.5.6.3 Accessing Box Information Screens.....                    | 39       |

|   |            |
|---|------------|
| 2.5.6.4 Reviewing Routing Box 800, 801, and 821<br>and Setting Up Single-Digit Call Routing ..... | 41         |
| 2.5.6.5 Setting Up Prototype Mailbox 9994 .....   | 42         |
| 2.5.6.6 Creating Subscriber Mailboxes.....  | 45         |
| 2.5.6.7 Customizing Subscriber Mailboxes.....   | 46         |
| 2.5.6.8 Customizing the System Supervisor Mailbox .....   | 55         |
| 2.5.6.9 Recording Routing Box Greetings.....  | 56         |
| 2.6 Default Database Structure Overview .....   | 58         |
| 2.7 Setting Up the System Using the Teleparameter Feature .....                                   | 60         |
| 2.7.1 Using the Teleparameter Feature to Set up a New System.....                                 | 61         |
| 2.7.1.1 Running the PBX Setup Utility .....   | 61         |
| 2.7.1.2 Adjusting System Information.....   | 65         |
| 2.7.1.3 Adjusting Routing Box Information.....  | 67         |
| 2.7.1.4 Creating and Adjusting Mailbox Box Information.....                                       | 67         |
| 2.7.1.5 Creating Other Box Types and Adjusting Information .....                                  | 68         |
| 2.7.2 Teleparameter Value Tables.....   | 69         |
| 2.7.3 Using the Teleparameter Feature to Adjust the System Setup .....                            | 100        |
| 2.8 Upgrading 2 Port Systems to 4 Ports.....  | 101        |
| <b>3. System Supervisor Instructions .....</b>  | <b>103</b> |
| 3.1 Working with Mailboxes .....  | 103        |
| 3.1.1 Adding, Deleting, or Modifying a Mailbox.....   | 103        |
| 3.2 Working with Routing Boxes .....  | 108        |
| 3.2.1 Understanding the Routing Box Setup .....   | 108        |
| 3.2.2 Recording Routing Box Greetings or Changing Currently Active Greetings .....                | 111        |
| 3.2.3 Changing the Single-Digit Call Routing .....  | 113        |
| 3.3 General System Maintenance .....  | 115        |
| 3.3.1 Enabling or Disabling a Port .....  | 115        |
| 3.3.2 Recording a Broadcast Message for All Mailboxes .....                                       | 116        |
| 3.3.3 Transferring a Caller to a Mailbox's Voice Mail .....                                       | 117        |
| 3.3.4 Troubleshooting System Problems.....  | 118        |

# 1. System Overview

This document discusses features and functionality provided in Small Office Lite™ and Debut™ systems. Note that both these systems include the same feature set, and the system setup and maintenance procedures are identical between systems. For documentation ease, these two systems are collectively referred to as the *Lite* system in this guide.

## 1.1 What Does the Lite System Do?

In its simplest form, the Lite system acts like a telephone receptionist. The system answers incoming calls and transfers them to the appropriate extension. If the called extension is not available (busy or no answer), the system offers to take a message or try an alternative extension.

Lite system functionality includes:

- Automated attendant features
- Voice mail features

These two functions work together to provide smooth call coverage for your application.

### 1.1.1 What is an Automated Attendant?

The Lite system automated attendant features perform the tasks of a live attendant. The following table illustrates how.

| Live Attendant                                     | Lite System Automated Attendant   |
|--|---|
| Answers an incoming call by lifting telephone.     | Answers an incoming call by going "off-hook."                                     |
| Greets the caller with "Welcome to [XYZ Company]." | Greets the caller by playing a pre-recorded greeting, "Welcome to [XYZ Company]." |



| Live Attendant  | Lite System Automated Attendant   |
|---|---|
| Asks to whom the caller wishes to speak.  | Plays a pre-recorded greeting that prompts the caller to either dial the extension of the party they are trying to reach or choose from a list of voiced options to route their call to a specific department or group. |
| Listens to the caller's response.   | Listens to the digits dialed by the caller.   |
| Says "Please hold."   | Plays a pre-record phrase " <i>Please hold...</i> "   |
| Calls the required extension, by hook-flashing and dialing the extension number.  | Calls the required extension, by hook-flashing and dialing the extension number.  |
| Listens for busy tone, ring tone, answer, etc.  | Listens for busy tone, ring tone, answer, etc.  |
| If the extension is busy, offers to let the caller hold. If the extension does not answer, offers to take a message or try another extension. | If the extension is busy, plays a pre-recorded prompt, offering the option to hold. If the extension does not answer, plays a pre-recorded prompt offering to take a message or try another extension.                  |

### 1.1.2 What is Voice Mail?

The term “voice mail” refers to systems that can record a voice message and treat it like a mail message. In a typical office environment, the live attendant takes a message from a caller and writes it down on a piece of paper. The attendant then places the slip in the recipient’s in-box or “mailbox.” The box owner then retrieves and reads the message placed in the box.

In contrast, the Lite system records a message from a caller and places it in a voice mailbox. The mailbox owner can later retrieve the message by calling into the Lite system and listening to the recording. The table below compares how the Lite system processes voice messages compared to a live attendant.

| Live Attendant   | Lite System Voice Mail  |
|--|---|
| Attendant listens as the caller dictates his/her message, writing it down on a piece of paper. | The Lite system records the message as the caller speaks.                                 |
| Attendant places the message slip in a mailbox belonging to the recipient.                     | The Lite system stores the voice message electronically in the recipient’s voice mailbox. |

| Live Attendant   | Lite System Voice Mail  |
|--|---|
| Attendant dials code to turn on message waiting lamp on recipient's telephone.               | The Lite system dials code to turn on the message waiting lamp on recipient's telephone.  |
| Recipient sees message waiting lamp is on, and retrieves message slips from message mailbox. | Recipient sees message waiting lamp is on and dials the Lite system to retrieve messages. |
| Recipient reads messages left on message slips.  | The Lite system plays messages recorded by callers in the voice mailbox.                  |

## 1.2 Understanding the Lite System Product Design

The Lite system is designed using the Box concept. A box contains a set of instructions that tell the program what to do with a call it is handling. By setting up the system to send calls to different boxes created on the system, you can have it effectively process calls—including playing certain prompts or greetings to callers, collecting information and messages from callers, and routing calls to certain extensions based on digits dialed by callers.

The Lite system product uses the same software base as Corporate Office™ and Small Office™ products, but it is limited in the number of boxes you can set up on the system. These limitations effectively position the Lite system as a product for smaller businesses needing a simple, reliable voice mail system without all the advanced features of a larger, more expensive system. As the needs of the Lite system user expand, Key Voice provides efficient, no-data-loss upgrades to Small Office or Corporate Office through an inexpensive and sensible upgrade plan.

Depending on the configuration purchased, the Lite system provides 5 Routing boxes and 25 mailboxes or 5 Routing boxes and 50 mailboxes. The Routing boxes are used to answer incoming calls, play a listing of options to callers, and route the call to a specific mailbox based on the digits dialed by the caller. The mailboxes transfer calls to their associated extensions and store messages for system subscribers, and they can be set up to forward calls to another phone or extension number, deliver messages to another phone or pager, play one of 9 pre-recorded greetings to callers, screen calls, queue calls when the extension is busy, or record call conversations.



## 2. System Setup Instructions

The Lite system contains a default database with a setup configuration that allows the Lite system to efficiently perform fundamental call processing tasks with minimal system adjustments by the installing technician. This default database configuration includes 2 pre-defined classes of service (0 and 7), 1 supervisor mailbox (mailbox 70), and 3 Routing boxes—800, 801, 821. Information provided in this document explain how these pre-set defaults function on the Lite system.

As you proceed through these setup instructions, you may decide to make adjustments to specific information relating to the default setup. You may even decide to set up the other 2 available Routing boxes to perform additional call routing tasks. As you make any changes, keep in mind that we urge you to maintain the initial general configuration of Routing boxes 800, 801, and 821, class of service 7, and supervisor mailbox 70. This configuration allows the Lite system to efficiently perform fundamental call processing tasks. Maintaining it helps both you, the technician, and Lite system technical support to efficiently service the system and resolve any call processing issues. For these reasons we urge you not to deviate from this general system setup default configuration.

Information on setting up and using box types other than Routing boxes and mailboxes is provided in the *Installation and Maintenance Manual*.

|  |
|--|
| <p><b>Note:</b> Section 2.6 provides an overview of the default database setup shipped on Lite system units.</p> |
|--|

### 2.1 Available System Setup Techniques

---

There are two techniques you can use to set up Lite systems:

- Attach a laptop to the Lite system unit and use the program's screen interface to run the System PBX Setup utility then complete System Information and Box Setup screens

- Call into the Lite system and use the Teleparameter feature to run the System PBX Setup utility then enter parameter codes and corresponding values to set up system and box information

This document provides instructions for using either system setup technique.

Technicians who have experience setting up Corporate Office, Small Office, or Lite systems may prefer to use the Teleparameter feature to quickly make modifications and get the Lite system up and running at the customer's site. Be advised, however, that since this technique involves inputting codes that represent system parameters and corresponding values to which parameters are to be set, it is a bit more difficult to use effectively if you are unfamiliar with setting up Corporate Office, Small Office, or Lite systems. For this reason, we recommend that technicians unfamiliar with Corporate Office, Small Office, or Lite systems attach a laptop to the PC and use the instructions provided here to complete all necessary system setup steps through the screen interface.

|   |
|---|
| <p><b>Note:</b> If you choose to set up the system using the Teleparameter feature, be sure to first review <b>section 2.5.6.2</b> and <b>2.6</b> so you clearly understand the setup of the default database included on the Lite system unit.</p> |
|---|

Note that if you choose to initially set up the system by connecting it to a laptop and using the screen interface, you can later make additional modifications by simply calling into the Lite system and using options on the Supervisor menu (see **section 3**) or using the Teleparameter feature (see **section 2.7.2**).

## 2.2 Preparing for System Setup

---

To install, set up, and maintain a Lite system voice processing system, you need the following equipment:

### Equipment Needed

- **Lite system unit**
- **Portable diskette drive**  
Should an unusual situation arise, it may be necessary for you to service the Lite

system by attaching a portable diskette drive to the Lite system unit. Therefore, we strongly recommended that technicians servicing Lite system units have access to a portable diskette drive.

- **Authorization key (Small Office Lite systems only)**

The Small Office Lite system runs only if the *authorization key* is attached to the PC's parallel port. This key is shipped in the packaging with the Lite system unit. To attach the authorization key, simply plug the key into the parallel port in the back of the PC. (Debut units do not require an authorization key.)

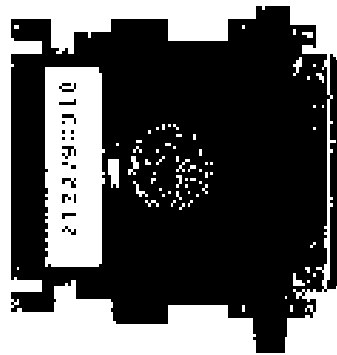

**Authorization Key**

If you choose to set up the system by connecting a laptop to the Lite system unit, you need the following additional equipment:

- **Laptop computer**
- **Null modem serial cable**
- **KeyLink communications software** (provided with the Lite system)

This additional equipment is necessary because the Lite system does not have a keyboard and monitor. To set up the system using a laptop, you must use a null modem serial cable to attach the laptop PC to the Lite system unit. So that the laptop computer can communicate with the Lite system unit, you must install KeyLink communication software, provided with the Lite system, onto the laptop PC. The KeyLink installation procedure is provided in this document.

Once the system is set up and tested, the system supervisor on-site can maintain the day-to-day aspects of the system (adding, deleting, modifying mailboxes; modifying greetings and call routing; etc.) by simply calling into the system using a telephone. No special Teleparameter modification instructions or laptop computers are necessary for regular daily maintenance of the Lite system.

## 2.3 Connecting the Lite System Unit to the Telephone System

The Lite system unit can be connected directly to local telephone lines, typically Centrex service, or behind a Key System or PBX. (For simplicity, the term “PBX” is used herein to mean “PBX or Key System”).

### 2.3.1 Connecting Directly to the Central Office (C.O.)

The Lite system unit can be connected directly to the telephone lines as shown below.

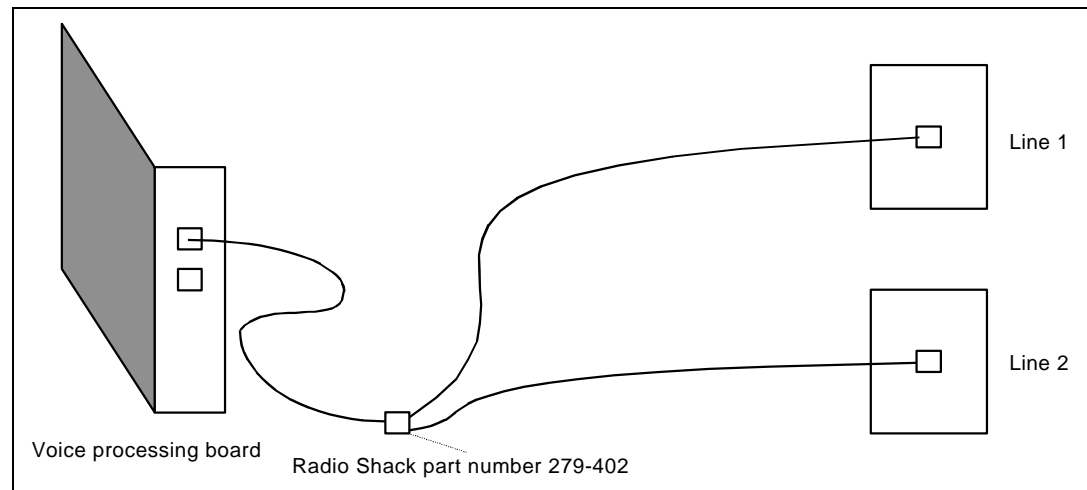

Connecting the Lite System Directly to Telephone Lines

Note that the modular input connectors on the voice boards are RJ-14 jacks which contain two independent telephone lines. The modular adapter shown (or its equivalent) must be used if the telephone lines are terminated with RJ-11 (single line) jacks.

If you want the Lite system to be able to transfer calls, make sure the telephone line has either the call-transfer or three-way calling feature. If you are unsure whether the lines have these capabilities, contact the local telephone company.

Local C.O. lines connected to the Lite system should *not* have the call-waiting feature assigned. Once again, if in doubt, contact the local telephone company.

### 2.3.2 Connecting the Lite System to a PBX or Key System

The Lite system unit connects to PBX station ports (each line to the Lite system unit looks like an extension to the PBX), as shown below. The Lite system thus functions as one or more extensions on the PBX.

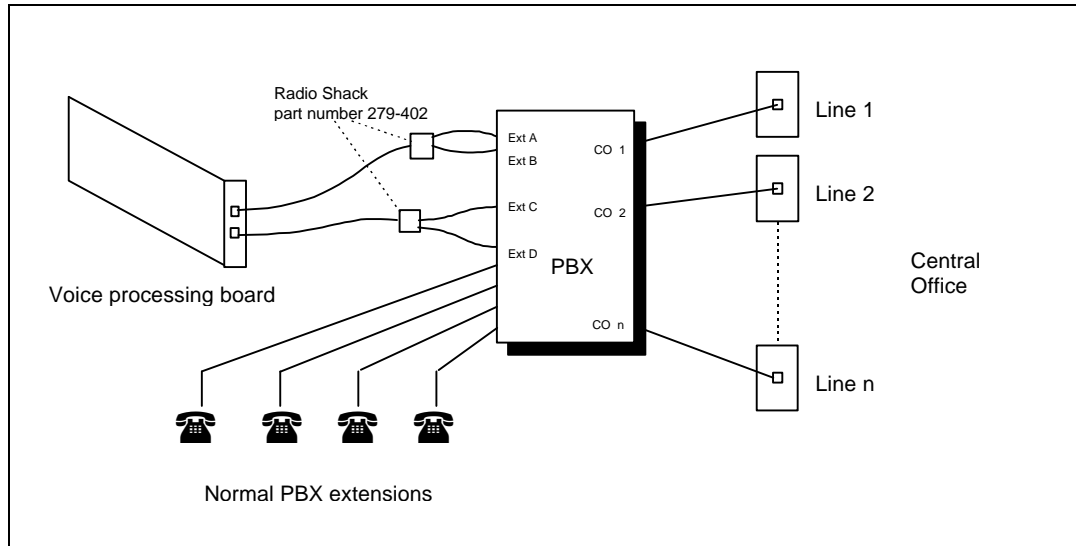

Connecting the Lite System Behind a Key System or PBX

Note that the modular input connectors on the voice boards are RJ-14 jacks, which contain two independent telephone lines. The modular adapter shown (or its equivalent) must be used if the PBX extensions are terminated with RJ-11 (single line) jacks.



Each line to the Lite system unit requires an industry-standard-telephone port on the PBX (this is also known by other names such as *analog port*, *2500 set interface*, *SLT port*.). Some telephone systems do not provide single-line-telephone ports, and they require a special analog interface box between the PBX and the voice-mail system, as shown below. If in doubt, contact the local PBX manufacturer's representative.

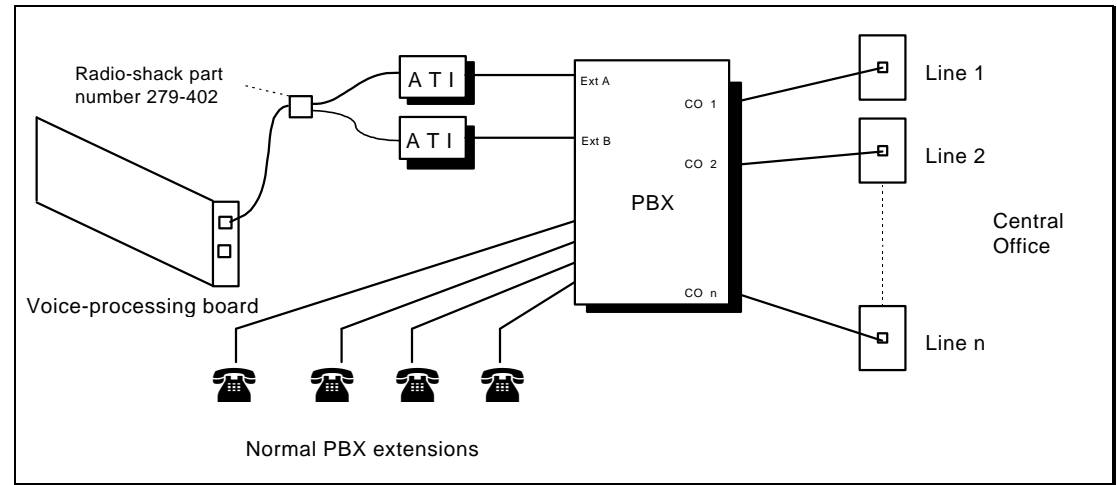

**Connecting the Lite System to a PBX via External Analog Telephone Interface (ATI) Equipment**

### Connecting the Serial Cable Between the Lite System Unit and PBX

If you are establishing a serial integration, you must attach a serial cable between the Lite system unit and the PBX. The Lite system unit is set up to use the COM 1 port to communicate with the phone system. Therefore, you should connect the serial cable to the Lite system unit's **COM 1** port.

Consult the phone system documentation for instructions on attaching the serial cable to the phone system COM port.

**Note:** If the phone system you are working with is a Comdial DSU (Impression 24, 48, 72), attach the serial cable to **COM 1** on the DSU. If the phone system is a DSUII (Impact 24, 48, 72), attach the serial cable to **COM 3** on the DSUII.

## Typical Setup

For typical automated attendant service, the PBX is programmed so that incoming calls are routed via the PBX to ring the Lite system. The Lite system answers the call and asks the caller to enter the required extension (or mailbox) number. The caller enters the number, and the Lite system transfers the call just as a live attendant would.

## **2.4 Collecting Necessary Customer Information**

---

While setting up the Lite system, you may need to adjust default settings for the customer's regular business open hours and business closed hours. You also need to set up Routing boxes to handle incoming calls and set up mailboxes for subscribers who will be using the system. The following worksheets are provided to help the installing technician collect this information from the system supervisor.



# Business Hours Worksheet

(System Supervisor Completes)

On the lines corresponding to each day of the week, write in 24-hour format (for example 8:00 PM is 20:00) the normal hours the company opens and closes for business. If the business is open 24 hours on a particular day, enter 0:00 as the **DAY SERVICE BEGINS** time and 24:00 as the **DAY SERVICE ENDS** time. If the business is closed the entire day on a particular day, enter 0:00 on both lines.

Indicate, if appropriate, any hour(s) during which the business closes during the day, for lunch or any other reason.

| BUSINESS HOURS                                      |                          |                        |                            |                          |
|---|--------------------------|------------------------|----------------------------|--------------------------|
|   | Day<br>service<br>begins | Day<br>service<br>ends | Lunch<br>service<br>begins | Lunch<br>service<br>ends |
| <b>SUN:</b>   | _____                    | _____                  | _____                      | _____                    |
| <b>Mon:</b>   | _____                    | _____                  | _____                      | _____                    |
| <b>Tue:</b>   | _____                    | _____                  | _____                      | _____                    |
| <b>Wed:</b>   | _____                    | _____                  | _____                      | _____                    |
| <b>Thu:</b>   | _____                    | _____                  | _____                      | _____                    |
| <b>Fri:</b>   | _____                    | _____                  | _____                      | _____                    |
| <b>Sat:</b>   | _____                    | _____                  | _____                      | _____                    |
| Change "Good afternoon" to "Good evening" at: _____ |                          |                        |                            |                          |

Specify the time of day the automated attendant should start answering calls with a "good evening" greeting.



# Subscriber Mailbox Information Worksheet

(System Supervisor Completes)

Photocopy this page, then complete the form for each subscriber who is to have a mailbox.

|   |   |
|---|---|
| <b>Subscriber Data</b>  |   |
| First name:   |   |
| Last name:  |   |
| Extension number:   |   |
| Should the system announce the caller's name to the subscriber upon transfer? |   |
| Should all conversations be recorded?   |   |
| <b>Paging Data</b>  | (complete only if subscriber is to use the feature)   |
| Pager number  |   |
| Pager type (circle one)   | TONE      DIGITAL   |
| Paging schedule (circle one)  | Always    During office open hours    During closed hours<br>Schedule*:    A    B    C    D |
| <b>Auto Message Forward and Message Delivery Data</b>                         | (complete only if subscriber is to use these features)                                      |
| Auto forward new messages:  | To box: _____ After _____ hours   |
| Auto forward new messages schedule (circle one):                              | Always    During office open hours    During closed hours<br>Schedule*:    A    B    C    D |
| Message delivery schedule 1:  | Number to call: _____   |
| When should delivery be active? (circle one):                                 | Always    During office open hours    During closed hours<br>Schedule*:    A    B    C    D |

Continued on back

|  |  |
|--|--|
| <p>Message delivery schedule 2:</p> <p>When should delivery be active? (circle one):</p> | <p>Number to call: _____</p> <p>Always    During office open hours    During closed hours<br/>Schedule*:    A    B    C    D</p> |
| <p>Message delivery schedule 3:</p> <p>When should delivery be active? (circle one):</p> | <p>Number to call: _____</p> <p>Always    During office open hours    During closed hours<br/>Schedule*:    A    B    C    D</p> |
| <p>Message delivery schedule 4:</p> <p>When should delivery be active? (circle one):</p> | <p>Number to call: _____</p> <p>Always    During office open hours    During closed hours<br/>Schedule*:    A    B    C    D</p> |
| <p>Message delivery schedule 5:</p> <p>When should delivery be active? (circle one):</p> | <p>Number to call: _____</p> <p>Always    During office open hours    During closed hours<br/>Schedule*:    A    B    C    D</p> |

\*If specifying a particular schedule, complete a subscriber schedule worksheet for the individual.

# Subscriber Schedule Worksheet

(System Supervisor Completes)

Photocopy this page, then complete the form for each subscriber who is using the Paging, Auto Message Forwarding, or Message Delivery out-calling features according to a particular schedule, as indicated on his/her Subscriber Mailbox Information sheet.

You can designate up to 4 different schedules below, then apply one schedule to each out-calling feature the subscriber will be using. Enter information for 1 to 4 schedules below in 24-hour format (for example 8:00 PM is 20:00). You do not need to complete the **BOX NUMBER** field.

| M A I L B O X      Page 3   |   |   |   |             |  |
|---|---|---|---|-------------|--|
| Box number: _____   |   | First Name: _____   |   | Last: _____ |  |
| <b>SCHEDULE A</b><br>Start    End<br>SUN: _____<br>Mon: _____<br>Tue: _____<br>Wed: _____<br>Thu: _____<br>Fri: _____<br>Sat: _____ | <b>SCHEDULE B</b><br>Start    End<br>Sun: _____<br>Mon: _____<br>Tue: _____<br>Wed: _____<br>Thu: _____<br>Fri: _____<br>Sat: _____ | <b>SCHEDULE C</b><br>Start    End<br>Sun: _____<br>Mon: _____<br>Tue: _____<br>Wed: _____<br>Thu: _____<br>Fri: _____<br>Sat: _____ | <b>SCHEDULE D</b><br>Start    End<br>Sun: _____<br>Mon: _____<br>Tue: _____<br>Wed: _____<br>Thu: _____<br>Fri: _____<br>Sat: _____ |             |  |





## **Routing Worksheet (System Supervisor Completes)**

---

Refer to **section 3.2** to familiarize yourself with the function of Routing boxes. This section also provides a sample of greetings that are typically recorded in the 3 Routing boxes pre-configured on the Lite system. After reviewing this information, complete this worksheet to indicate the wording for the greetings you want this Lite system to voice.

Note that you should indicate in your greeting any single-digit call routing options you want to provide to callers (“...*Press 2 for Sales...*”) and identify the extension to which a caller pressing that single-digit number should be transferred.

### **Office Open Greeting:**

---

---

---

### **Single digit routing paths:**

---

### **Office Closed Greeting:**

---

---

---

### **Single digit routing paths:**

---

Continued on back

**Office Holiday Greeting:**

---

---

---

**Single digit routing paths:**

---

## 2.5 Setting Up the System by Attaching a Laptop

---

Use the information in this section to complete all necessary system setup steps by attaching a laptop computer to the Lite system unit and using the Lite system's screen interface to run the PBX Setup utility and to complete System Information and Box Setup screens.

### 2.5.1 Installing KeyLink Software onto the Laptop

1. Insert the KeyLink diskette into the diskette drive on the laptop computer. Change to the diskette drive by typing **A:** then pressing <Enter> (where **A** is the drive letter for the diskette drive).
2. To start the installation process, type **INSTALL** then press <Enter>. The KeyLink remote system communication program creates the \KEYLINK directory on the laptop's hard drive, then copies the KeyLink remote system communication program to that directory. (The KeyLink host system communication program is pre-loaded on the Lite system.)
3. When all the necessary files have been copied to the \KEYLINK directory, a message displays indicating the installation is complete.

### 2.5.2 Connecting the Laptop to the Lite System Unit

You connect the Lite system unit to the laptop computer using a null modem serial cable.

When you install KeyLink software on the laptop computer, the program defaults to using the COM 1 port on the laptop. Therefore, unless you change this default, you should connect one end of the null modem serial cable to the laptop's **COM 1** port. Attach the other end of null modem cable to the **COM 2** port if you are using the **Small Office Lite** system unit or the **COM 1** port if you are using the **Debut** system.

#### Establishing a Communication Link Between the Laptop and Lite System Unit:

1. To access the Lite system program screens from the laptop PC, change to the \KEYLINK directory, then type **REMOTE** and press <Enter>.

- 
2. A screen displays, prompting you to indicate the type of connection you are establishing. To indicate you are using a null modem cable connection, type **N** then press <Enter>.
3. The screen refreshes with a display that emulates the Lite system unit. The keyboard and monitor of the laptop now effectively control the Lite system unit.

**Note:** If the screen displays a message indicating the program is shutting down communications, you may need to adjust the COM port settings specified in the KeyLink program. Do this by repeating step 1, then typing **P** to select Port Assignments (instead of **N**) in step 2. Using the up and down arrows, select the COM port to which the null modem cable is installed, then press <Enter>. Repeat steps 2 and 3.

If the appropriate COM port combination is specified, and you still cannot establish communication with the Lite system unit, verify that you are using a true **null modem** cable. Because it is difficult to visually distinguish null modem cables from other serial cables, some users mistakenly use the wrong cable type.

- 
- 
- 
4. Follow the procedures in this document to set up the Lite system.

**Note:** If you type **EDIT** to invoke a DOS editor on the Lite system unit, you will invoke a special editor pre-installed on the unit. This editor was developed specifically for use with a null modem cable. (Traditional DOS editors cannot communicate effectively over a null modem cable.)

- 
- 
- 
- 
5. To break the connection between the laptop and Lite system unit, press <Ctrl>-<Break>. The KeyLink program ends its communication with the Lite system unit, and the laptop screen refreshes. To re-establish communication with the Lite system, repeat step 1.

**Note:** For information on transferring files between the Lite system and the attached PC, refer to section 10 of the Installation and Maintenance Manual or contact Key Voice technical support.

## 2.5.3 Completing the First Time Setup Procedure

Once you connect the Lite system to the phone system and access the Lite system using a laptop computer, you are ready to begin customizing the system. Customizing the system involves:

- Running the PBX Setup utility
- Specifying System Information
- Specifying Routing Box and Mailbox Information

## 2.5.4 Running the PBX Setup Utility

The Lite system voice processing software is pre-installed on the Lite system unit before it is shipped to you. You must, however, run the PBX Setup utility so you can configure certain installation parameters for each specific customer's site.

On **Debut** units, you must run the PBX Setup utility using the teleparameter feature. See **section 2.7.1** and **section 2.7.1.1** for procedures. Once you run the utility, continue with **section 2.5.5** for information on specifying system information.

On **Small Office Lite** systems you can run the PBX Setup utility through the screen interface or using the teleparameter feature discussed in section 2.7.1. To run the utility through the screen interface, use the following procedure.

1. Make the Lite system unit hard disk the current drive, by typing **C:** then pressing <Enter>.
2. To switch to the VM directory, type **CD\VM** then press <Enter>.
3. To invoke the Install program, type **INSTALL** then press <Enter>.
4. When the main Install menu displays, use the ↓ key to highlight **FIRST TIME SETUP** then press <Enter>.
5. When prompted, type **C:\VM** then press <Enter> to indicate the directory in which the Lite system is installed.

6. The system warns that it may over-write some changes to the Lite system database. To continue, **press <Y>**.
7. At the system prompt for the **number of digits** in the extension numbers, enter the appropriate number, then press <Enter>. At the system prompt to confirm your entry, press <Enter>.
8. A list of telephone systems displays. Note that you can use the <PgUp> and <PgDn> keys to scroll through all available selections. Enter the **number corresponding to the telephone** system with which you are working, then press <Enter>. If the phone system is not on the list, select option **0 DON'T KNOW (OR UNLISTED)** then press <Enter>.
9. The system prompts you to confirm your selection. To continue, **press <Y>**.
10. At the system prompt regarding message waiting lights, **press <Y>**.
11. The system prompts you to indicate the **number of telephone lines** connected to the Lite system. Enter the appropriate number, then press <Enter>.
12. The system prompts you for the number of digits you want to use in mailbox passwords. Indicate the **number of digits** subscribers are to use, then press <Enter>. (You may want to consult the system supervisor, in case he/she has a digit-length preference.)
13. The system prompts you to confirm your selection. To continue, **press <Y>**.
14. The system prompts you to automatically create mailboxes at this point. **Though you may elect to create mailboxes now, we strongly recommend that you select No, so you can first make any necessary modifications to the prototype mailbox, which serves as a template for creating mailboxes.** By properly setting up the prototype mailbox, you simplify the number of adjustments you must make to refine the mailboxes for each user. To continue without setting up mailboxes at this time, **press <N>**.
15. Depending on the phone system you selected, you may be prompted for additional information. Enter the appropriate responses.
16. The system prompts you to use U.S. Daylight-Savings Time. To have the system automatically adjust the clock so it accommodates Daylight-Savings Time for the next 10 years, **press <Y>**. If you do not want the system to automatically adjust for U.S. Daylight-Savings Time, **press <N>**.
17. The main Install program screen displays. To continue, **select Exit** then press <Enter>.

18. The Install program must reboot the Lite system unit to make the changes indicated.  
**Press <Y>** when the system displays the reboot prompt. After the system reboots, the Line Status screen displays.

## 2.5.5 Specifying System Information

System Information screens contain system setup information that applies system-wide, to all boxes set up on the system. There are six System Information screens:

- General Information Screen
- Line Information Screen
- Business Hours Screen
- Call Transfer Screen
- Class of Service Screen(s)
- Other Customizations Screen

Before you set up Routing boxes and mailboxes, it is best to ensure all System Information screens are properly completed.

**Note:** Because the default information on System Information screens is set so the Lite system is operational with as few changes as possible, the procedures provided in this document for entering data on System Information screens do not go into detail about all the screen entries. Instead, the procedures guide you through accessing and reviewing pertinent fields on certain screens, so you can verify that default data is properly set and modify it if absolutely necessary. If you need to make additional changes to the System Information screens, refer to information provided in the *Installation and Maintenance Manual*.

Note that you can access online help at any time by pressing <F1>.

### 2.5.5.1 Integration Defaults Set by the Integration Program

When you run the PBX Setup utility (previous procedure), you are prompted to indicate the type of telephone system the customer is using. If you are installing the Lite system on one



of the phone systems identified below, the Integration program automatically sets fields on several System Information screens to the phone system's default settings. Unless you customize the phone system defaults, you probably do not need to modify these settings.

- Comdial DigiTech / Impact / DSU - Serial Integration
- Comdial DigiTech / Impact / DSU - Serial Integration - IVPC
- Comdial DXP, DXP Plus, FX - Serial Integration
- Comdial DXP, DXP Plus, FX - Serial Integration - IVPC
- Comdial Executech 2000
- Comdial Unisyn
- Cortelco Aries
- Encore CX - ECX 1832 / 3672 / 36112
- Ericsson MD-110
- Fujitsu 9600 with Serial Integration
- Fujitsu Allegra 26
- Fujitsu Series 3 / Starlog
- Fujitsu Starlog
- Harris 20/20
- Isoetec IDS 108 / 228
- Isoetec System 96
- ITT / Cortelco System 3100
- Iwatsu ADIX
- Iwatsu ZT-D
- Lucent Definity G3 – Calista Box – Vectoring – Bridged Mode
- Lucent Definity G3 – VoiceBridge
- Lucent Definity G3 – VoiceBridge – Vectoring – Bridged Mode
- Lucent Merlin II
- Lucent Merlin Legend
- Lucent Partner ACS
- Lucent Partner II
- Lucent Partner Plus
- Lucent System 25
- Lucent System 75
- Lucent System 85 and Definity Generic 2 – VoiceBridge
- Mitel COV with D/42D-SX Voice Boards
- Mitel SX100 Digital PABX with ONS Integration
- Mitel SX200 Light with COV Integration
- Mitel SX200 Light with DNIC Integration

- Mitel SX200 Light with ONS Integration
- Mitel SX2000 and SX2000 Light with COV Integration
- Mitel SX2000 and SX2000 Light with DNIC Integration
- Mitel SX50 with COV Integration
- Mitel SX50 with DNIC Integration
- NEC Electra Professional Level I
- NEC Electra Professional Level II
- NEC Mark II
- NEC NEAX-1400 IMS
- NEC NEAX-2000
- NEC NEAX-2400 Serial Integration
- Nitsuko DSO-1 / ONYX / 124i / 384i
- Northern Telecom Norstar - With VMI Adapters
- Northern Telecom SL-1 and Meridian-1/SL-1, (with D42-SL)
- Panasonic 1232 - Analog
- Panasonic DBS
- Panasonic KXT-336
- Panasonic KX-TD 1232 Digital
- Panther II 820 / 1032 / 2064 Release IV
- Philips SOPHO-S
- Premier ESP / Intertel GMX
- Redwood 3.2
- Rolm 9200 BCS / Siemens HCM 200
- Samsung Prostar 56EX / 120MX / 1224
- Samsung Prostar DCS - Digital
- Siemens Saturn I, II, III
- SMDI Installation Guide / Centrex
- Southwestern Bell Landmark DKS 308 / 616
- Sprint Protégé / Macrotel MT360 / 824 KSU
- Tadiran Coral I, II, & III
- Telrad 2464
- Telrad Digital Key BX, 200 Digital
- Toshiba DK-16 / 24 / 56 / 96
- Toshiba DK-280
- Toshiba Perception E
- Toshiba Perception EX
- Toshiba Perception I & II
- Vodavi DHS

- Vodavi Infinite DVX1, DVX2, & DVX3
- Vodavi Starplus 2448EX / 4896EX
- Vodavi Starplus 96EX
- Vodavi Starplus Digital
- Win 100D

If you are using a telephone system that is not listed here, the Integration program sets fields on System Information screens to commonly used defaults. You may need to adjust these settings.

For detailed information on integrating the Lite system with the phone system, refer to both the *Installation and Maintenance Manual* and the technical bulletin for the phone system.

### 2.5.5.2 Using Technical Bulletin Information

For almost every phone system supported by the Lite system, there is a technical bulletin that details system-specific installation information and considerations. This information is particularly useful if you are working with a phone system that is not on the list shown in the previous section, since you may more likely need to adjust certain settings on System Information screens.

You can obtain technical bulletins through the Key Voice fax distribution system. To access this system, phone (941) 922-3800 and press 7 at the main greeting. Follow the system prompts and, when requested, enter the number corresponding to the bulletin for the phone system with which you are working. To obtain a listing of all available bulletins and their associated bulletin numbers, request document **01**.

### 2.5.5.3 Accessing System Information Screens

1. From the Line Status screen, **press <F10>**. The Main menu displays, and you are prompted to enter a system password.
2. At the prompt to enter the system password, press <Enter>. (The default Customer level password is blank. The default Technician level password is **1234** on Small Office Lite systems or, on Debut units, **the last four digits of the bar code** on the white sticker on the bottom of the unit.)

3. From the Main Menu, select **SYSTEM INFORMATION**. The System Information menu displays.

#### 2.5.5.4 Setting Up the General Information Screen

1. From the System Information menu, select **GENERAL**. The General Information setup screen displays.
2. Press <Enter> to move the cursor to the **AUTOMATICALLY EXIT TO DOS AT** field. **Enter the time** at which the Lite system should exit to DOS to perform its auditing functions. The default setting is 3:00 AM.
3. To save the information and exit the screen, **press <F10>**. The System Information menu displays.

#### 2.5.5.5 Setting Up the Line Information Screen

1. From the System Information menu, select **LINE INFORMATION**. The Line Information setup screen displays. Each row on this screen corresponds to one line connected to the Lite system.
2. Press <Enter> to move the cursor to the Initial Box field under Day Service for line 1. Verify that **800** displays in this field, indicating that calls received during Day Service hours are to go to Routing box 800.
3. Press <Enter> to move the cursor to Initial Box field under Night Service for line 1. Verify that **801** displays in this field, indicating that calls received after the day service hours are to go to Routing box 801.
4. Press <Enter> to move the cursor to the Initial Box field under Lunch Service for line 1. Verify that **800** displays in this field, indicating that calls received during Lunch Service are also to go to Routing box 800.
5. Press <Enter> to move the cursor to the **OUTGOING ALLOWED** field for line 1. Verify this field is set to **No**.
6. Repeat steps 3 through 5 for each line on the screen. For the last line, however, be sure to verify that **Yes** in the **OUTGOING ALLOWED** field.

7. To save the information and exit the screen, **press <F10>**. The System Information menu displays.

#### 2.5.5.6 Setting Up the Business Hours Screen

1. From the System Information menu, select **BUSINESS HOURS**. The Business Hours setup screen displays.
2. For each day of the week, enter the **office opening time** in the **DAY SERVICE BEGINS** field and the **office closing time** in the **DAY SERVICE ENDS** field. The default is an office open time of 8:00 AM and office closing time of 17:00 (5:00 PM). If you want calls to be handled in the same way day and night, enter **00:00** in the **DAY SERVICE BEGINS** field, and **24:00** in the **DAY SERVICE ENDS** field. Refer to the Business Hours Worksheet completed by the system supervisor for specific information.
3. To save the information and exit the screen, **press <F10>**. The System Information menu displays.

#### 2.5.5.7 Setting Up the Call Transfer Screen

1. From the System Information menu, select **CALL TRANSFER**. The Call Transfer setup screen displays.
2. The fields in the top half of the screen list the sequences that the Lite system is to dial to transfer calls (the “!” signifies *hook-flash* and the comma signifies *pause for one second*). Typically, these settings are appropriate for most telephone systems without any modification. If you *know* the actual sequences required by the telephone system, and they are different from those shown, make the changes as necessary.
3. To save the information and exit the screen, **press <F10>**. The System Information menu displays.

#### 2.5.5.8 Setting Up the Class of Service Screen

Each mailbox on the system is assigned a class of service. The class of service assigned to the box dictates which Lite system features the mailbox owner has access to and how he/she can use those features.

There are 8 classes of services (0 through 7) that can be set up then applied to mailboxes on the Lite system. Two of them are pre-configured on the system. Class of service 0 is assigned by default to the prototype mailbox 9994, which serves as a template for every mailbox that you create on the system. Class of service 7 is assigned supervisor mailbox privileges. This class of service is assigned to mailbox 70, which is also pre-configured on the system. Mailbox 70, therefore, serves as the supervisor mailbox. By calling into the system and accessing the supervisor mailbox, the system supervisor can make necessary day-to-day modifications to the voice processing system, such as adding mailboxes, changing Routing box greetings, etc. See **section 3** for details.

1. From the System Information menu, select **CLASS OF SERVICE**. The Class of Service setup screen displays.
2. Use the information provided below to review and, if necessary, adjust the fields on two different Class of Service screens. First, review class of service 0, which functions as the class of service that will be assigned to subscriber mailboxes on the system. When you reviewed the screen for class of service 0, **press <F6>** to progress through the classes of service and go to the setup screen for class of service 7.

Review and, if necessary, adjust class of service 7. Ensure that in class of service 7 the **SUPERVISOR STATUS?** field is set to **Yes**. This allows the owner of the mailbox assigned this class of service to access the Supervisor menu over the telephone. Using this menu, the system supervisor can call into the system to perform day-to-day maintenance on the system.

| CLASS OF SERVICE   |  |  |  |
|--|--|--|--|
| Class-of-service number: <b>0</b>  |  | CLASS-OF-SERVICE NAME: <span style="background-color: black; color: black;">XXXXXXXXXX</span>  |  |
| Maximum number of greetings: <b>1</b>                                    | Maximum greeting length (secs): <b>60</b>                                |  |  |
| Maximum number of messages: <b>200</b>                                   | Maximum message length (secs): <b>60</b>                                 |  |  |
| Auto-delete OLD messages from system after <b>30</b> days.               |  |  |  |
| Auto-delete NEW messages from system after <b>99</b> days.               |  |  |  |
| Supervisor status ?  | <b>No</b>  | Play menu after greeting?  | <b>No</b>  |
| Access to Group-boxes ?  | <b>Yes</b>   | Allowed to receive faxmail?  | <b>No</b>  |
| Dial-out allowed?  | <b>No</b>  | Operator Box (Day): <b>888</b>   | (Night): <b>888</b>  |
| Access to P.A.?  | <b>Yes</b>   | When exiting open Mail Box, go to box <b>321</b>   |  |
| Max lines allowed to hold for one box: <b>2</b>                          |  | Digits allowed while holding: <span style="background-color: black; color: black;">XXXX</span> |  |
| While in queue, say position in line? <b>No</b>                          |  |  |  |
| Try extension <b>3</b> times, before going back to caller.               |  |  |  |
| RESTRICTED NUMBERS   |  |  |  |
| Digits: <span style="background-color: black; color: black;">XXXX</span> | Digits: <span style="background-color: black; color: black;">XXXX</span> | Digits: <span style="background-color: black; color: black;">XXXX</span>                       | Digits: <span style="background-color: black; color: black;">XXXX</span> |
| Digits: <span style="background-color: black; color: black;">XXXX</span> | Digits: <span style="background-color: black; color: black;">XXXX</span> | Digits: <span style="background-color: black; color: black;">XXXX</span>                       | Digits: <span style="background-color: black; color: black;">XXXX</span> |
| F1=Help  |  | F5=Previous COS  |  |
| F6=Next COS  |  | F10=Exit   |  |

### CLASS OF SERVICE NUMBER

This field indicates the number of the class of service you are currently working with. To move to the next class of service number, press <F6>. Once you assign a class of service to a mailbox, the mailbox inherits all the privileges and restrictions defined in the class of service.

### CLASS OF SERVICE NAME

Use this field to give the class of service a meaningful name. This helps remind you of the purpose for the class of service. Sample names include *Supervisors*, *Subscribers*, etc.

### MAXIMUM NUMBER OF GREETINGS

A mailbox can have up to 10 pre-recorded personal greetings. The mailbox owner may record these greetings, store them in the mailbox, then choose the greeting that is to be active at any specific time. You may want to offer use of all 10 greetings to users or restrict them to fewer greetings. Use this field to define how many personal greetings users with this class of service should be allowed to record. If you set the field to 0, then callers who route to a

mailbox belonging to this class of service always hear the pre-recorded system prompt, "*That extension is not available...*" The default setting is **10**.

Note that in class of service 7, this field must be set to allow at least 2 greetings. Class of service 7 is assigned to mailbox 70, the supervisor mailbox that controls the Routing boxes on the system. Because you will be setting up these Routing boxes with at least 2 greetings, this parameter must be set to at least **2** in the supervisor mailbox class of service.

#### **MAXIMUM GREETING LENGTH**

When a mailbox owner calls in to re-record his/her personal greeting, the Lite system limits the length of the new greeting to the value entered in this field. The default setting is **60**.

#### **MAXIMUM NUMBER OF MESSAGES**

The Lite system can hold up to 200 messages per mailbox. However, you may want to restrict some mailboxes to a lower limit (to conserve disk space). Use this field to define the maximum number of messages that can be stored in mailboxes assigned this class of service. Once the limit is reached for a particular mailbox, callers attempting to leave more messages in the mailbox are told that the box is full. The default setting is **200**.

#### **MAXIMUM MESSAGE LENGTH**

The value in this field defines the maximum length of a message (in seconds) that a caller can leave for mailboxes belonging to this class of service. The default setting is **60**.

#### **AUTOMATICALLY DELETE OLD MESSAGES FROM SYSTEM AFTER X DAYS**

The Lite system deletes messages saved as Old from mailboxes belonging to this class of service after the number of days you specify. An old message is one the mailbox owner has listened to, but has not yet deleted. If you enter **0** in this field, an old message is deleted at midnight on the day the message became old. If you enter **1** in this field, an old message is deleted at midnight on the day following the day the message became old.

To disable deletion of Old messages, enter **99** in this field. However, do this with caution, since accumulating messages may create disk storage problems. The default setting is **30**.



## AUTOMATICALLY DELETE NEW MESSAGES AFTER X DAYS

|  |
|--|
| <p><b>Note:</b> Use this parameter with caution. Improper use may cause important messages to be lost.</p> |
|--|

The Lite system deletes new messages from mailboxes belonging to this class of service after the number of days you specify. A new message is one the mailbox owner has not yet listened to. If you enter **0** in this field, a new message is deleted at midnight on the day the message was received. If you enter **1** in this field, a new message is deleted at midnight on the day following the day the message was received.

To disable the deletion of new messages, retain the default setting of **99** in this field. This is the default operating mode. If you enter a number other than 99 in this field, remember that messages are deleted whether or not the mailbox owner has listened to them.

## SUPERVISOR STATUS

This field defines whether mailboxes belonging to this class of service should have supervisor privileges. A supervisor can perform certain actions not available to regular mailbox owners. For example, a supervisor can add a mailbox or delete a mailbox by calling in from any telephone. Additional information on supervisor functions is provided in **section 3**. The default setting in class of service 0 is **No**, in class of service 7 is **Yes**.

## ACCESS TO GROUP BOXES

By setting this field to **Yes**, you allow subscribers assigned this class of service to access any Group boxes set up on the system. For information on setting up and using Group boxes, refer to the *Installation and Maintenance Manual*. The default setting is **Yes**.

## DIAL-OUT ALLOWED

This field indicates whether the owner of a mailbox belonging to this class of service is allowed to place outgoing calls from the mailbox. The default setting is **No**.

## ACCESS TO P.A.

When a caller is listening to a mailbox owner's greeting, one of the features the Lite system offers is the option to have the call announced over the P.A. system. Use this field to allow

or deny access to the P.A. feature for callers to mailboxes belonging to this class of service. The default setting is **Yes**.

#### **PLAY MENU AFTER GREETING**

If an extension is busy or does not answer, the Lite system plays the mailbox owner's personal greeting. After playing the greeting, it can announce the options available to the caller (for example, *"If you would like to leave a message, press 1. To try another extension, press 3, or to speak with an operator, press 0."*). If the mailbox owners do not record these options as part of their greetings, set this field to **Yes** so that the Lite system plays the menu. If you want to allow each mailbox owner to decide which options to offer, set this field to **No** and instruct each mailbox owner to include the options in his/her personal greeting. The default setting is **No**.

#### **ALLOWED TO RECEIVE FAXMAIL**

The Lite system users should retain the default setting **No** in this field.

#### **OPERATOR BOX (DAY) (NIGHT)**

When a caller is listening to a mailbox greeting, one of the options is to dial zero to reach an operator. Use these fields to indicate the mailbox to which the call should be routed if the caller indicates that he/she wishes to speak with an operator. The default setting is **888**.

#### **WHEN EXITING OPEN MAILBOX, GO TO BOX**

When a mailbox owner has logged in to his/her box, has concluded listening to messages, changing options, etc., and has selected to exit from the Main menu, this field tells the Lite system where to send the call. The Lite system users should retain the default setting in this field as **821**.

#### **MAX LINES ALLOWED TO HOLD FOR ONE BOX**

You can limit the number of lines that can simultaneously hold for a mailbox belonging to this class of service. For example, if you set this number to 3, and lines 1, 3, and 6 are holding for a mailbox, then subsequent callers are not offered the option to hold. Instead, they hear the personal greeting recorded for the box, so they can leave a message, try another extension, etc. The default setting is **2**.

**Note:** If you want to disable the Call Queuing feature for the class of service, set this field to **0**.

#### **DIGITS ALLOWED WHILE HOLDING**

While a caller is in the queue holding for an extension, he/she can press a digit to leave the queue and process the call differently. By default, the options open to the caller are the same as those available when the caller hears the personal greeting (*"If you would like to leave a message, press 1. To try another extension, press 3, or to speak with an operator, press 0."*). If you want to restrict the caller to fewer choices while in the queue, use this field to specify which digits are allowed. All other digits are ignored by the Lite system while the caller is in the queue. For example, if you enter 13 in this field, the only options available to the caller are:

- 1 To leave a message
- 3 To try another extension

#### **WHILE IN QUEUE, SAY POSITION IN LINE**

While a caller is in the queue, holding for an extension, the Lite system can keep him/her informed on the progress of the call. If you set this field to **Yes**, the Lite system announces to the caller:

*"That extension is still busy. You are number [x] in line. If you would prefer to leave a message, press 1, or to speak with an operator, press 0."*

If you select **No** in this field, the Lite system voices:

*"That extension is still busy. If you would prefer to leave a message, press 1, or to speak with an operator, press 0."*

The default setting is **No**.

#### **TRY EXTENSION X TIMES, BEFORE GOING BACK TO CALLER**

This parameter applies only if the **MAX LINES ALLOWED TO HOLD** field is greater than 0. If the caller chooses to hold, the Lite system plays a series of hold prompts to the caller (these are typically music or commercials). At the end of each hold prompt, the Lite system tries the extension again. If it is busy, then the next hold prompt is played to the caller.

After the defined number of hold prompts have been played, the Lite system goes back to the caller and offers the options to remain on hold, try another extension etc. This field allows you to specify the number of hold prompts that should be played before the Lite system offers these options to the caller.

As shipped, the Lite system has only one hold prompt recorded (system prompt #146, see the *Installation and Maintenance Manual*). Therefore, if you enter 3 in this field, a caller queued to a busy station hears this same prompt three times before being offered the options again. If you record the second hold prompt (#147), then the caller hears prompt # 146, #147, then #146 again before being offered the options. You may record up to 100 different hold prompts, which are played in sequence. (Remember: At the end of *each* hold prompt, the Lite system tries the extension again). After the Lite system plays the highest number hold prompt recorded, it returns to the lowest number after the next try. The default setting is **3**.

|   |
|---|
| <p><b>Note:</b> The time between tries to a busy extension is determined by the length of each hold prompt recorded. The prompt supplied with the Lite system (#146) is approximately 30 seconds.</p> |
|---|

## RESTRICTED NUMBERS

When a mailbox owner calls in to change his/her call-transfer number, pager number, or message notification number, you may want to prevent him/her from changing it to certain numbers, such as long-distance numbers.

These fields allow you to define digit sequences that are to be blocked. The Lite system looks at each of these Digits fields to determine if any of them match the number entered by the mailbox owner. If the number entered by the caller begins with the digits specified in the Digits field, the Lite system defines the number entered as a match.

For example, if you enter the digits 1900 in one of the Digits fields, the Lite system considers 1-900-555-1212, 1-900-123-4567, 1-900-111-2222 to be matches. Telephone number 1-901-555-1212 would not be considered a match.

If you enter the digit 0 in one of the digits fields, the Lite system considers all numbers beginning with 0 to be matches. This would include calls to the operator (0), calls to the long-distance operator (00), international calls (011), and any operator-assisted call (0 followed by telephone number).

If the caller enters a number that matches one of the digit strings you enter here, the Lite system informs the mailbox owner that the number is not acceptable and retains the current set up.

Once you review and adjust all fields on both Class of Service setup screen 0 and Class of Service setup screen 7, **press <F10>** to save the information and exit. The System Information menu displays.

You have now reviewed the necessary entries on the System Information screens. To return to the Line Information screen, **press <F10>**.

## **2.5.6 Specifying Box Information**

### **2.5.6.1 What Is a Box?**

When the Lite system answers a call, it processes it by sending it to a *box*. Each box performs a specific function (for example, playing a menu to the caller and waiting for a response). It then passes the call to another box, which in turn performs its specific function, etc.

Depending on the configuration purchased, the Lite system provides 5 Routing boxes and 25 mailboxes or 5 Routing boxes and 50 mailboxes. The Routing boxes are used to answer incoming calls, play a listing of option to callers, and route the call to a specific mailbox based on the digits dialed by the caller. The mailboxes transfer calls to their associated extensions and store messages for system subscribers, and they can be set up to forward calls to another phone or extension number, deliver messages to another phone or pager, play one of 9 pre-recorded greetings to callers, screen calls, queue calls when the extension is busy, or record call conversations.

### **2.5.6.2 Understanding Routing Box 800, 801, and 821**

According to the entries specified on the Line Information screen, the Lite system will route all incoming calls to Routing box 800. This box answers calls during the day and lunch service hours and plays a greeting to callers. After day/lunch service hours, the system routes

calls to Routing box 801. Typically, companies offer more extensive call routing options to callers during day/lunch service hours than during closed hours. Often, for example, single-digit call routing (“...Press 2 for Sales...” ) is not offered during closed hours. Therefore, the greeting voiced by and options available in Routing box 801 are often different than those in Routing box 800.

So that the system supervisor can alter the system to voice a generic holiday greeting on holidays the office is closed, you will set up both Routing box 800 and 801 to include a holiday greeting alternative. Therefore, procedures in this document guide you through recording two greetings in both boxes 800 and 801: an office open greeting and a holiday greeting in box 800, and an office closed greeting and a holiday greeting in box 801. (Keep in mind that holidays last 24 hours, therefore calls received on a holiday may be processed by either box 800 or 801, depending on when the call is received. For this reason, a holiday greeting must be recorded in both box 800 and 801). Sample greetings for these boxes are provided in **section 3.2.1**.

Routing Box 821 is designed by default to take over and route calls once they have passed through Routing box 800 or 801. A call may go to Routing box 821, for example, after the caller leaves a voice message in a subscriber’s mailbox. Routing box 821 offers callers a menu similar to Routing box 800, but box 821 is pre-configured so if a caller does not enter an extension or select a menu option, the call is disconnected. In Routing box 800 and 801, callers who do not enter an extension or select an option are transferred to the operator. This is a safety measure designed to assist callers who use rotary phones or are too slow to respond to system prompts. By disconnecting non-responsive callers in box 821, the system simply assumes that the caller knew how to select menu options in box 800 or 801, and therefore, since no option was selected in box 821, the caller hung up.

Because we recommend you record two greetings in both Routing box 800 and 801, you will not use the **GREETING RECORDED** field on the Routing Box setup screens. This field allows you to record only one greeting for the Routing box. Instead you will record all necessary greetings by following the steps in the **section 2.5.6.9**, which you will complete after you review and set up the Routing boxes and mailboxes.

### **2.5.6.3 Accessing Box Information Screens**

1. From the Line Status screen, **press <F10>**. The Main menu displays and you are prompted to enter a system password.
2. At the prompt to enter the **system password**, press <Enter>.

3. From the Main Menu, select **BOX INFORMATION**. The Box Information menu displays.

You should review the setup for the following boxes:

- Routing Box 800
- Routing Box 801
- Routing Box 821
- Prototype Mailbox 9994
- Supervisor mailbox 70

After you review and, if necessary, adjust prototype mailbox 9994, you use it to set up subscriber mailboxes. You then make necessary adjustments to these mailboxes to customize them for system subscribers. This section details the steps you must follow to set up all necessary boxes and make the required adjustments.

The following procedures identify screen setup entries necessary for the Lite system to effectively process calls. Fields that are not specifically discussed contain default values that should be appropriate in nearly all setup situations. Detailed information on all fields on Routing Box and Mail Box setup screens is provided in the *Installation and Maintenance Manual*. You can also access online help on any screen by pressing <F1>.

### 2.5.6.4 Reviewing Routing Box 800, 801, and 821 and Setting Up Single-Digit Call Routing

1. From the Box Information menu, select **ROUTING BOX**. The Routing Box setup screen displays.

```

ROUTING BOX
-----
Box number : 800      BOX NAME :Main Greeting
Greeting recorded : No      Owner: 70
Number of times to play the greeting : 1
Number of seconds to wait for a digit: 1

If no digits dialed, Go to box ... - box 821
If invalid digit dialed, go to box 800
Route the call based on :Digit dialed
When digit received, wait for more digits? Yes
-----
Destination for digit 1 :      6 :      * : 9998
                        2 :      7 :      # : 9992
                        3 :      8 :
                        4 :      9 :      Voice:
                        5 :      0 : 888
    
```

2. Press <F4> to access the box selection screen. A small window displays prompting you for the box number. Type 800 then press <Enter>.
3. Press <Enter> to move the cursor moves to the **OWNER** field. So that more than one greeting can be recorded and stored for use with this Routing box, this box should be identified as being owned by the supervisor mailbox, mailbox 70. By specifying a mailbox owner for this Routing box, the box takes on certain “mailbox” attributes, which include being allowed to house the same number of greetings as the mailbox owner’s mailbox. (You specified this number when you set up class of service 7.)
4. Press <Enter> to move the cursor to the **DESTINATION FOR DIGIT** fields. If you are setting up the system to provide single-digit call routing options to callers, complete these fields. Refer to the Routing Worksheet completed by the system supervisor for specific information on entries for these fields. Do not modify the **DESTINATION FOR DIGIT** \* and # fields.



5. Repeat steps 2 through 5 to set up Routing box 821. In step 2, type **821** (instead of 800) to access box 821. In the **DESTINATION FOR DIGITS** field, we recommend you make the same entries as you did on the setup screen for box 800.
6. Repeat steps 2 through 5 to set up Routing box 801. In step 2, type **801** (instead of 800) to access box 801. In the **DESTINATION FOR DIGITS** field, you may decide to modify or simply not include the single-digit dialing options, since this box will control how calls are routed when the office is closed. If you choose to use the same single-digit dialing options, simply re-enter them here.
7. To save all setup entries and exit the Routing Box setup screen, **press <F10>**. The Box Information menu displays.

#### 2.5.6.5 Setting Up Prototype Mailbox 9994

You need to create a mailbox for each subscriber who will use the system to record messages. Since most of the setup information will be the same for every mailbox you need, you should review the system's prototype mailbox, which is used as the mailbox setup model. The prototype mailbox is box number 9994. Every time you select to create a new mailbox, the system does so by making a copy of mailbox 9994.

1. From the Box Information menu, select **MAIL BOX**. The Mail Box setup screen displays with the Page Number menu.
2. **Press <F4>** to access the box selection screen. A small window displays prompting you for the box number. Type **9994** then press <Enter>.
3. Press <Enter> to move the cursor to the **TRANSFER TYPE** field. When a call is routed to the mailbox, the first action taken is to transfer the call to the number specified in the **TO:** field. The Lite system offers several options as to how the call can be transferred. When you move the cursor to this field, the various options are presented in a menu.

All transfer type options are described below. Use this information to select a transfer type. Note that in almost all system setups, you should select either the **Blind** or **Wait for Ring** transfer type, so the system can function most efficiently. The default setting is Wait for Ring.

### **NO TRANSFER**

The Lite system does not transfer the call. Instead, it plays the mailbox owner's personal greeting (if one has been recorded) or a system default greeting. The caller then has several available options before recording a message.

### **BLIND**

The Lite system transfers the call by dialing the number, then dropping out of the call. It transfers the call without monitoring to check whether the called party is busy, answers, etc. The final outcome of the call is the total responsibility of telephone system. If the telephone has transfer-recall capabilities, then if the telephone system transfer-recall timer expires, the call is returned to the Lite system. (The Lite system cannot perform call queuing when using Blind call transfers.)

### **WAIT FOR RING**

This is a combination of the Wait For Answer and Blind transfer types. If the called party is busy, the calling party is offered the same options as with the Wait For Answer transfer type. If ringing is detected on the line, the Lite system executes a Blind transfer and drops out of the call. (The Lite system *can* perform call queuing if the extension is busy.)

### **WAIT FOR ANSWER**

The Lite system dials the number and monitors the line. If the called party is busy, the Lite system offers the caller options to hold, leave a message, call another extension, etc. If the called party is not busy, the Lite system monitors the line, waiting for the called party to answer. If the called party does not answer within a specified number of rings, the Lite system abandons the transfer and plays the personal greeting, takes a message, etc. If the called party *does* answer, the Lite system announces the call "*I have a call for you, <mailbox owner's name>*" and completes the transfer. (The Lite system can perform call queuing if the extension is busy.)

### **SCREEN**

This transfer type functions exactly the same way as with the Wait For Answer transfer type until the called party answers. Once the called party answers, the Lite system plays a system prompt offering the called party several options:

- Press 1 to accept the call. The parties are connected.

- Press 2 to have the system voice the mailbox owner's currently active greeting to the called party.
- Press 3 to send the calling party to the destination selected in the **IF CALLER CHOOSES OTHER OPTIONS** field on Page 2 of the mailbox's Mail Box setup screens.
- Press 4 plus a greeting number (0 through 9) to play the selected greeting to the caller, provided that the greeting has been recorded.
- Press 5 plus any valid box number to send the calling party to that box, where the call is treated as would any other call to that box.
- Press 6 to accept the call. The parties are connected, but the Lite system remains connected to the call and records the conversation. The recording is stored as a message in the called party's mailbox (provided the host telephone system allows conferencing on voice mail ports).

(With the Screen transfer type option, the Lite system can perform call queuing if the extension is busy.)

4. Press <Enter> to move the cursor to the **TO:** field, and confirm the letter **X** displays in this field. This entry instructs the Lite system to transfer calls to the extension number that matches the box number.
5. Press <Enter> to move the cursor to the **CURRENTLY ENABLED** field. Verify this field is set to **Yes**.
6. Press <Enter> to move the cursor to the **TRANSFER SCHEDULE** field. Verify this field is set to **Always**.
7. Press <Enter> to move the cursor to the **SEQUENCE TO TURN ON MESSAGE WAITING LAMP** field. The entries displayed in this field were set during program setup and should be sufficient. Review the settings shown, and make any changes you feel are necessary. For details, refer to the phone documentation and technical bulletin for the phone system.

**Note:** The letter **X** represents the box number, a comma (,) represents a pause, and an exclamation point (!) represents a hookflash. For example, if the Lite system needs to dial the extension number, then hookflash and dial 44 to turn on a message waiting lamp, this field should read: !,44

8. Press <Enter> to move the cursor to the **SEQUENCE TO TURN OFF MESSAGE WAITING LAMP** field. The entries displayed in this field were set during program setup and should be sufficient. Review the settings shown, and make any changes you feel are necessary. For details, refer to the phone documentation and technical bulletin for the phone system.
9. **Press <F9>** to move to page 2 of the Mail Box setup screen.
10. Press <Enter> to move the cursor to the **AFTER PLAYING GREETING** field. Verify this field is set to **Wait For A Digit**.
11. To save the prototype mailbox setup you specified and exit the setup screens, **press <F10>**. The program displays the Box Information menu.

### 2.5.6.6 Creating Subscriber Mailboxes

Once you set up Prototype mailbox 9994, you can now efficiently set up all the mailboxes that will be used by subscribers on the system.

1. From the Box Information menu, select **MAIL BOX**. The Mail Box setup screen displays.
2. To add a new mailbox, **press <F2>**.
3. A small window displays prompting you for the box number. Enter the **number of the first mailbox** you want to create, then press <Enter>.

**Note:** Enter as the mailbox number the same number as the extension to which the mailbox will transfer calls. Also, note that the default password for each mailbox is the same as the box number.

4. The Lite system creates the new mailbox by making a copy of the Prototype mailbox. The new mailbox is displayed on the screen.

5. Repeat steps 3 through 5 for each subscriber mailbox you want to create.
6. Once you create all necessary mailboxes, continue with the next procedure, below.

### 2.5.6.7 Customizing Subscriber Mailboxes

Using information the system supervisor provides on the Mailbox Setup Worksheets, you can now customize the mailboxes you created for each subscriber on the system.

The procedure below identifies the fields you should be sure to customize for each mailbox. Fields that are not specifically discussed contain default values that should be appropriate in nearly all setup situations. Therefore, it is unlikely that you need to modify these fields. Detailed information on completing all fields on Mail Box setup screens is provided in the *Installation and Maintenance Manual*. You can also access online help on any screen by pressing <F1>.

1. To access the mailbox you want to customize, **press <F4>**. A small window displays prompting you for the box number. Type **the box number** then press <Enter>. The Mail Box Page 1 setup screen displays.

| M A I L B O X Page 1  |   |
|---|---|
| Box number: 10 FIRST NAME: Sample Last: Mail box  |   |
| <b>CALL TRANSFER INFORMATION</b><br>Transfer type: [REDACTED]<br>To: X [REDACTED]<br>Rings to answer: 4<br>Use 3-way calling? No<br>Get caller's name? No<br>Record conversation? No<br>Currently enabled? Yes<br>Transfer schedule: Always | <b>PERSONAL DATA</b><br>Password: 10 [REDACTED]<br>Name recorded: No [REDACTED]<br>Greeting recorded: No [REDACTED] |
| <b>PRIVILEGES</b>   |   |
| Class of service: 0 [REDACTED]  |   |
| Restricted - Client of: [REDACTED]  |   |
| Sequence to turn ON message-waiting lamp: [REDACTED]  | New: 0 [REDACTED]   |
| Sequence to turn OFF message-waiting lamp: [REDACTED]   | Old: 0 [REDACTED]   |
| F1=Help F2=Add F3=Delete F4=Select F5=Prev F6=Next F9=Next page F10=Exit  |   |

2. Press <Enter> to move the cursor to the **FIRST NAME** field. Enter the mailbox owner's first name. Press <Enter> to move the cursor to the **LAST** field. Enter the mailbox owner's last name.
3. To go to Page 2 of the Mail Box setup screen, **press <F9>**. The Page 2 screen displays.

| M A I L B O X (Page 2)   |                |                             |          |            |        |
|--|----------------|-----------------------------|----------|------------|--------|
| Box number:  | 10             | First Name:                 |          | Last:      |        |
| PAGER NUMBER:  |                | Pager type:                 | Digital  | Enabled?   | No     |
| Times to call:   | 1              | Mins between calls:         | 0        | Schedule:  | Always |
| After playing greeting:  |                |                             |          |            |        |
| If caller chooses "other options": Go to box ... - box 821               |                |                             |          |            |        |
| After leaving message, Go to box ... - box 821                           |                |                             |          |            |        |
| If call is via D.I.D. play greeting in language: 1                       |                |                             |          |            |        |
| Auto-forward NEW msgs to box after 0 hours. Schedule: Always             |                |                             |          |            |        |
| MESSAGE DELIVERY -   | Where and When | Repeat                      | Interval | Schedule   |        |
| Call:  |                | 2                           | 60       | Schedule A |        |
| Call:  |                | 3                           | 10       | Schedule B |        |
| Call:  |                | 3                           | 10       | Schedule C |        |
| Call:  |                | 3                           | 10       | Always     |        |
| Call:  |                | 3                           | 10       | Always     |        |
| Run this cycle 1 times.  |                | Currently enabled? Disabled |          |            |        |
| F1=Help F2=Add F3=Delete F4=Select F5=Prev F6=Next F9=Next page F10=Exit |                |                             |          |            |        |

- Press <Enter> to move the cursor to the **PAGER NUMBER** field. If the subscriber is to use the Paging feature, use the following information to complete this section of the Mail Box setup screen.

#### PAGER NUMBER

Enter the telephone number of the paging service. The mailbox owner may change the number remotely. Normally, access codes for outside lines are not required here. Instead, that information should be entered on the System Information / General setup screen.

To restrict pager calls to use lines in a particular line group, enter the letter (A, B, C, or D) of the line group in braces { } before the telephone number (for example, {A}5551212).

Tone or Voice pagers may be used with the Message Delivery feature discussed later in this section.

The pager number you enter can contain the digits 0 through 9, star (\*), pound (#), and the following special characters:

| Character           | Use   |
|---------------------|---|
| P                   | Use pulse (also known as 'rotary') dialing.   |
| T                   | Use tone dialing (the default).   |
| ,                   | Short pause (duration can be changed in Technical Information screen. Default is one second).   |
| %                   | Medium pause (equal in length to 4 commas).   |
| L                   | Long pause (equal in length to 8 commas).   |
| !                   | Hookflash.  |
| N                   | No progress tones (must be last character). The Lite system ignores all call progress tones during the course of the call. When it has finished dialing, the system immediately assumes that the pager system has answered. |
| [ ]                 | Enclosing the number in brackets prevents the mailbox owner from being able to call in and change the number.   |
| { }                 | Specifies a line group is to be used (for example, {A}555-1212 indicates "choose any line in line group A, and dial the number 555-1212").  |
| any other character | Can be used for punctuation and is ignored.   |

### PAGER TYPE

The Lite system supports both Tone and Digital pagers in this section of the mailbox programming. Specify here which type of pager the mailbox owner has (Digital, Tone or None).

When a caller asks the Lite system to page a mailbox owner, the Lite system looks for a free line on which to call the paging service. If no lines are free to make the call, the Lite system queues the request and re-tries every 10 seconds for approximately 10 minutes.



**NUMBER OF TIMES TO CALL**

The Lite system calls the pager the number of times you specify in this field. Repetitive paging may be useful if the pager is turned off periodically or is out of pager range.

**Note:** This field is used to tell the Lite system how many successful calls it should make to the paging service. Do not confuse this with the pager-retry feature. If the Lite system calls the pager number and does not hear it ring and answer, then it automatically re-tries the call at 10-second intervals, for a pre-defined number of times.

**MINUTES BETWEEN CALLS**

If you enter a number greater than 1 in the **TIMES TO CALL** field, this field instructs the Lite system how long it should wait between re-calls.

**Note:** This field tells the Lite system how long to wait between successful calls to the paging service. Do not confuse this with the pager-retry feature.

**CALL SCHEDULE**

The Pager notification feature follows a time schedule. The options are:

| Schedule               | Result   |
|------------------------|--|
| ALWAYS                 | Pager notification is available at all times.  |
| DAY SERVICE            | Pager notification is available only during day/lunch service, as defined in the System Information / Business Hours screen.     |
| NIGHT SERVICE          | Pager notification is available only during non-day/lunch service, as defined in the System Information / Business Hours screen. |
| SCHEDULE A, B, C, or D | Pager notification is available only during the schedule defined on Page 3 of the Mail Box setup screen for this mailbox.        |

**ENABLED**

Set this field to **Yes** to indicate that the pager feature for this mailbox is currently on. Set the field to **No** to indicate that the pager feature is off. The mailbox owner can also toggle this field on and off by calling into the system. If this field is set to **No**, it overrides the call schedule set in the previous field.

5. Press <Enter> to move the cursor to the first **MESSAGE DELIVERY** field. If the subscriber is to use the Message Delivery feature, use the following information to complete this section of the Mail Box setup screen.

**CALL**

Enter the telephone number the Lite system should call to inform the mailbox owner that there are new messages in his/her mailbox.

The number can contain the DTMF digits 0 - 9, \* and #, plus any of the following special characters:

| Character | Use  |
|-----------|--|
| P         | Use pulse (also known as 'rotary') dialing.  |
| T         | Use tone dialing (the default).  |
| ,         | Short pause (duration can be changed in Technical Information screen. Default is 1 second).  |
| %         | Medium pause (equal in length to 4 commas).  |
| L         | Long pause (equal in length to 8 commas).  |
| !         | Hookflash.   |
| [ ]       | Enclosing the number in brackets prevents the mailbox owner from being able to call in and change the number.  |
| { }       | Specifies a line group is to be used (for example, {A}555-1212 indicates "choose any line in line group A, and dial the number 555-1212").   |
| H         | Hang up immediately after dialing the number (must be last character).   |
| M         | Answering machine. This must be the last character in the telephone number. It tells the Lite system that the number being called has an answering machine attached. When the Lite system calls the number, it announces that there are messages, as usual. If the Lite system has not |

| Character           | Use   |
|---------------------|---|
|                     | received a DTMF digit (1 for Yes, anything else for No), by the end of the announcement cycle(s), it assumes that it is talking to an answering machine, and proceeds to play each new message in turn.   |
| V                   | Voice pager. This must be the last character in the telephone number. Details of voice pager programming are found later in this section.   |
| I                   | Internal (must be the first character). Overrides the INTERNAL parameter (in the configuration file VM.CFG) and treats this number as an internal call regardless of the number of digits. The Lite system does not dial the sequence specified in the General Information / Digits To Get A Line On External Call field. |
| E                   | External (must be the first character). Overrides the INTERNAL parameter (in the configuration file VM.CFG) and treats this number as an external call regardless of the number of digits. The Lite system dials the sequence specified in the General Information / Digits To Get A Line On External Call field.         |
| N                   | No progress tones (must be the last character). The Lite system ignores all call progress tones during the course of the call.  |
| any other character | Can be used for punctuation and is ignored.   |

The owner of a mailbox can call in and remotely change the first Message Notification number, but cannot use or modify special characters.

#### REPEAT

Enter the number of successful calls to each telephone number. A successful call is generally defined as one where the Lite system has seized an available line port, dialed the number, and detected an answer. If the call is not successful (for example, the called number was busy) the Lite system automatically re-tries every few seconds up to twenty times.

#### INTERVAL

If the Repeat field contains a number greater than 1 or there are additional Call number sequences, enter the interval (in minutes) between calls to this number and/or the interval before proceeding to the next Call number sequence.

**SCHEDULE**

Select when the Lite system should call this number. The options are:

| Schedule               | Result  |
|------------------------|---|
| ALWAYS                 | The number is called any time a new message is left in the mailbox.   |
| DAY SERVICE            | The number is called only during day/lunch service, as defined in the System Information / Business Hours screen.     |
| NIGHT SERVICE          | The number is called only during non-day/lunch service, as defined in the System Information / Business Hours screen. |
| SCHEDULE A, B, C, or D | The number is called only during the schedule defined on Page 3 of the Mail Box setup screen for this mailbox.        |

**RUN THIS SEQUENCE N TIMES**

Once the Lite system has called every number listed, it considers that it has run the sequence one time. It will then check the value in this field. If this field is set to a number higher than 1, the Lite system starts again and repeats the sequence the specified number of times.

**CURRENTLY ENABLED?**

This field identifies which messages the Lite system is to deliver:

|                  |   |
|------------------|---|
| DISABLED         | The Lite system does not deliver messages.  |
| URGENT MSGS ONLY | The Lite system delivers only messages marked urgent, but does not call to deliver non-urgent messages. |
| ALL MESSAGES     | The Lite system calls every time a message is deposited into the mailbox.                               |

Setting this field to **DISABLED** overrides the **SCHEDULE** field.

The owner of a mailbox can call in remotely and turn his/her Message Delivery feature on or off, or change the first number to be called. The other telephone numbers, if in use, cannot be changed remotely.

6. To go to Page 3 of the Mail Box setup screen, **press <F9>**. The Page 3 screen displays.

| M A I L B O X Page 3   |       |                    |            |                |           |
|--|-------|--------------------|------------|----------------|-----------|
| Box number: 10   |       | First Name: Sample |            | Last: Mail box |           |
| SCHEDULE A   | Start | End                | SCHEDULE B | Start          | End       |
|  | SUN:  | 0:00 0:00          |            | Sun:           | 0:00 0:00 |
|  | Mon:  | 0:00 0:00          |            | Mon:           | 0:00 0:00 |
|  | Tue:  | 0:00 0:00          |            | Tue:           | 0:00 0:00 |
|  | Wed:  | 0:00 0:00          |            | Wed:           | 0:00 0:00 |
|  | Thu:  | 0:00 0:00          |            | Thu:           | 0:00 0:00 |
|  | Fri:  | 0:00 0:00          |            | Fri:           | 0:00 0:00 |
|  | Sat:  | 0:00 0:00          |            | Sat:           | 0:00 0:00 |
| SCHEDULE C   | Start | End                | SCHEDULE D | Start          | End       |
|  | Sun:  | 0:00 0:00          |            | Sun:           | 0:00 0:00 |
|  | Mon:  | 0:00 0:00          |            | Mon:           | 0:00 0:00 |
|  | Tue:  | 0:00 0:00          |            | Tue:           | 0:00 0:00 |
|  | Wed:  | 0:00 0:00          |            | Wed:           | 0:00 0:00 |
|  | Thu:  | 0:00 0:00          |            | Thu:           | 0:00 0:00 |
|  | Fri:  | 0:00 0:00          |            | Fri:           | 0:00 0:00 |
|  | Sat:  | 0:00 0:00          |            | Sat:           | 0:00 0:00 |
| F1=Help F2=Add F3=Delete F4=Select F5=Prev F6=Next F9=Next page F10=Exit |       |                    |            |                |           |

7. Press <Enter> to move the cursor to the first **SCHEDULE A** field. If the subscriber is to use the Pager or Message Delivery feature according to a particular schedule, use the following information to complete the Mail Box Page 3 setup screen.

**START**

Enter the time at which this schedule should begin on this day. The time should be entered in 24-hour format (for example, enter 20:00 for 8:00 PM).

**END**

Enter the time at which this schedule should end on this day. The time should be entered in 24-hour format (for example, enter 20:00 for 8:00 PM).

**Note:** If you want the schedule to be active all day, enter 00:00 as the **START** time and 24:00 as the **END** time.

- To go to Page 4 of the Mail Box setup screen, **press <F9>**. The Page 4 screen displays.

| M A I L B O X (Page 4)   |      |                      |     |
|--|------|----------------------|-----|
| Box number:  | 10   | First Name:          |     |
|  |      | Last:                |     |
| Hotel guest privileges only? No  |      |                      |     |
| WAKE-UP TIME:  | 7:00 | Currently scheduled? | No  |
| PERSONAL DISTRIBUTION LISTS  |      |                      |     |
| Name:  |      | Name:                |     |
| Enabled?   | Yes  | Enabled?             | Yes |
| Members:   |      | Members:             |     |
| Name:  |      | Name:                |     |
| Enabled?   | Yes  | Enabled?             | Yes |
| Members:   |      | Members:             |     |
| Name:  |      | Name:                |     |
| Enabled?   | Yes  | Enabled?             | Yes |
| Members:   |      | Members:             |     |
| Name:  |      | Name:                |     |
| Enabled?   | Yes  | Enabled?             | Yes |
| Members:   |      | Members:             |     |
| F1=Help F2=Add F3=Delete F4=Select F5=Prev F6=Next F9=Next page F10=Exit |      |                      |     |

- Confirm that the **ENABLED** field is set to **Yes** for all four personal distribution lists. This allows subscribers to create up to 4 personal distribution lists in their mailboxes, which they can then use when sending messages to groups of subscribers.
- Repeat steps 1 through 9 to customize each mailbox you created for each subscriber on the system. Once you customize all subscriber mailboxes, continue with the next procedure.

### 2.5.6.8 Customizing the System Supervisor Mailbox

- To access the system supervisor mailbox, **press <F4>**. A small window displays prompting you for the box number. Type **70** then press **<Enter>**.
- Press **<Enter>** to move the cursor to the **FIRST NAME** field. Type **SUPERVISOR** in this field. Press **<Enter>** to move the cursor to the **LAST** field. Enter the **system supervisor's last name**. Note that though you may type any name or words in these fields, using these

entries identifies this mailbox as the supervisor mailbox and identifies the individual who is currently acting as the on-site system supervisor.

3. Press <Enter> to move the cursor to the **CLASS OF SERVICE** field. Verify that **7** is entered in this field. This entry assigns class of service 7, which has supervisor privileges, to this mailbox.
4. To go to Page 2 of the Mail Box setup screen, **press <F9>**. The Page 2 screen displays.
5. To complete the supervisor mailbox setup, repeat steps 4 through 9 of the previous procedure.
6. To save all mailbox customizations and exit the Mail Box setup screen, **press <F10>**. The Box Information menu displays.

### 2.5.6.9 Recording Routing Box Greetings

As described in **section 2.5.6.2**, the following procedure guides you through recording two greetings in both Routing boxes 800 and 801: an office open greeting and a holiday greeting in box 800, and an office closed greeting and a holiday greeting in box 801. Sample greetings for these boxes and for box 821 are provided in **section 3.2.1**.

**Note:** When you record Routing box greetings, you must include instructions that identify any single-digit call routing options available to the caller.

1. From a telephone, call into voice mail and log into **supervisor mailbox 70**. Note that the default password for the mailbox is the same as the mailbox number, 70.
2. The Lite system tutorial session starts. Complete the tutorial. When prompted to record the name and greeting, you may elect to identify this as the supervisor mailbox. When changing the password, be sure to inform the system supervisor of the number you select. When you complete the tutorial, press <\*> to prevent it from voicing the next time the box is accessed.
3. The system voices the Main menu:

*“To listen to your messages press 1. To send a message press 2. To change your options press 3.”*

**Press 3** to change options. The system voices the Options menu:

| <b>Options Menu</b>                          |         |
|--|---------|
| To Record Your Name                          | Press 1 |
| To Record Your Greeting                      | Press 2 |
| To Change Your Password                      | Press 3 |
| To Change Your Call-Transfer Feature         | Press 4 |
| To Change Your Message Notification Feature  | Press 5 |
| To Change Your Pager Feature                 | Press 6 |
| To Review Msgs Scheduled for Future Delivery | Press 7 |
| To Change Your Personal Distribution Lists   | Press 8 |
| To Retrieve a Message Previously Sent        | Press * |
| To Return to the Main Menu                   | Press # |

4. From the Options menu, **press 2**.
5. When prompted, **press 800** to indicate you want to work with Routing box 800.
6. When prompted, **press 1** to confirm the number you entered or press # if the number you entered was incorrect. Once you press 1 to confirm, the system voices the following options:

|                           |         |
|---------------------------|---------|
| To Replay the Greeting    | Press 1 |
| To Re-Record the Greeting | Press 2 |
| To Delete the Greeting    | Press 3 |
| To Choose a New Greeting  | Press 5 |
| To Exit                   | Press # |

7. To record the first greeting for the Routing box, **press 2**. The system prompts you to enter the number of the greeting you want to record. Enter **greeting number 0**. Then, follow the prompts to **record the office open greeting**.
8. To record the holiday greeting for Routing box 800, repeat step 7, select **greeting number 1**, and **record the holiday greeting**.



9. To record greeting(s) for Routing box 801, **press <#>** to exit the menu shown above and return to the Options menu. Then repeat steps 4 through 7 above. In step 5, **press 801** to indicate you want to work with Routing box 801. In step 7, **record the office closed greeting**, instead of the office open greeting.
10. To record the holiday greeting for Routing box 801, repeat step 7, select **greeting number 1**, and **record the holiday greeting**.
11. To record the greeting for Routing box 821, **press <#>** to exit the menu shown above and return to the Options menu. Then repeat steps 4 through 7 above. In step 5, **press 821** to indicate you want to work with Routing box 821. In step 7, **record the office open greeting** call routing options, **omitting the introductory remarks** “Welcome to ...”
12. When you have recorded all necessary greetings, **press <#>** to return to the Options menu, then press <#> to return to the Main menu.

Be sure to instruct the system supervisor to refer to **section 3.2** for detailed instructions on changing the active Routing box greetings and recording new greetings.

---

## 2.6 Default Database Structure Overview

---

As mentioned previously, the Lite system contains a default database with a setup configuration that allows the Lite system to efficiently perform fundamental call processing tasks with minimal system adjustments by the installing technician. Information in this section highlights portions of this default database configuration. More detailed information on the purpose of Routing boxes and mailboxes and how box settings and other default settings affect system functionality is provided earlier in this document.

**Note:** Though you may make adjustments to specific information relating to this default setup, **you are urged to maintain the general configuration of Routing boxes 800, 801, and 821, class of service 7, and supervisor mailbox 70.** This configuration allows the Lite system to efficiently perform fundamental call processing tasks. Maintaining it helps both you, the technician, and the Lite system technical support to efficiently service the system and resolve any call processing issues.

- **Technician Password:**
  - \* Small Office Lite systems: 1234
  - \* Debut systems: the last 4 digits of the bar code on the white sticker on the bottom of the unit
  
- **Business Hours** (specified on System Information / Business Hours screen):
  - \* 8:00 AM - 5:00 PM
  
- **Routing Box 800:**
  - \* Answers all incoming calls during day/lunch hours (specified on System Information / Business Hours screen)
  - \* Owned by mailbox 70
  
- **Routing Box 801:**
  - \* Answers all incoming calls during non-day/lunch hours (specified on System Information / Business Hours screen)
  - \* Owned by mailbox 70
  
- **Routing Box 821:**
  - \* Routes calls that have already passed through Routing box 800 or 801
  - \* Owned by mailbox 70
  
- **Class of Service 0:**
  - \* Set up with the following parameter settings (for information on specific parameter fields, refer to **section 2.5.5.8**):

MAXIMUM NUMBER OF GREETINGS: **10**  
MAXIMUM NUMBER OF MESSAGES: **200**  
MAXIMUM GREETING LENGTH (SECS): **60**  
MAXIMUM MESSAGE LENGTH (SECS) **60**  
AUTO-DELETE OLD MESSAGES AFTER **30** DAYS.  
AUTO DELETE NEW MESSAGES AFTER **99** DAYS.  
SUPERVISOR STATUS? **No**  
ACCESS TO GROUP-BOXES? **Yes**  
DIAL-OUT ALLOWED? **No**  
ACCESS TO P.A.? **Yes**  
PLAY MENU AFTER GREETING? **No**  
ALLOWED TO RECEIVE FAXMAIL? **No**  
OPERATOR BOX (DAY): **888** (NIGHT): **888**  
WHEN EXITING OPEN MAILBOX, GO TO BOX: **821**

MAX LINES ALLOWED TO HOLD FOR ONE BOX: **2**

WHILE IN QUEUE, SAY POSITION IN LINE? **No**

TRY EXTENSION **3** TIMES BEFORE GOING BACK TO CALLER

RESTRICTED DIGITS: [**None**]

- **Class of Service 7:**
  - \* Set up with the class of service 0 options, but with SUPERVISOR STATUS? **enabled**.
- **Extension Length:**
  - \* 3 digits
- **Password Length:**
  - \* 4 digits
- **Default Passwords:**
  - \* Equal the mailbox numbers
- **Mailbox 70:**
  - \* Set up as the Supervisor mailbox with CLASS OF SERVICE: 7
- **Prototype mailbox 9994** (features automatically assigned to all mailboxes created):
  - TRANSFER TYPE: **Wait for Ring**
  - CLASS OF SERVICE: **0**
  - To: **x** (*signifies the mailbox number*)
  - CURRENTLY ENABLED: **Yes**
  - TRANSFER SCHEDULE: **Always**
  - PASSWORD: **x** (*signifies the mailbox number*)
  - SEQUENCE TO TURN ON/OFF MESSAGE WAITING LAMP: (*set by Integration program*)
  - AFTER PLAYING GREETING: **Wait for digit**

## 2.7 Setting Up the System Using the Teleparameter Feature

---

This section provides instructions on using the teleparameter feature to set up a new system at a customer site or to later make modifications to the system. Using the teleparameter feature, you can change the parameter values that affect system-wide setup information, box setups, and VM.CFG file data by simply calling into the system. You simply log into supervisor mailbox 70 over the telephone, select to modify system parameters, then, as prompted, enter

codes that identify each parameter you want to change and the new value to which you want to set the parameter. The screen illustrations and parameter value table provided in this section indicate the parameters and their associated codes.

Technicians who have experience setting up Corporate Office, Small Office, or the Lite systems may prefer to use the Teleparameter feature to quickly make modifications and get the Lite system up and running at the customer's site. Be advised, however, that since this technique involves inputting codes that represent system parameters and corresponding values to which parameters are to be set, it is a bit more difficult to use effectively if you are unfamiliar with setting up Corporate Office, Small Office, or Lite systems. For this reason, we recommend that technicians unfamiliar with Corporate Office, Small Office, or Lite systems attach a laptop to the PC and use the instructions provided in the previous sections to complete all necessary system setup steps.

|   |
|---|
| <p><b>Note:</b> If you choose to set up the system using the Teleparameter feature, be sure to first review <b>section 2.5.6.2</b> and <b>section 2.6</b> so you clearly understand the setup of the default database included on the Lite system unit.</p> |
|---|

## 2.7.1 Using the Teleparameter Feature to Set up a New System

### 2.7.1.1 Running the PBX Setup Utility

The Lite system voice processing software is pre-installed on the Lite system unit before it is shipped to you. You must, however, run the PBX Setup utility so you can configure certain installation parameters for each specific customer's site. Use the following procedure to run this utility by calling into the system over the telephone:

1. From a telephone, call into voice mail and log into **supervisor mailbox 70**. Note that the default password for the mailbox is the same as the mailbox number, 70.
2. The Lite system tutorial session starts. Complete the tutorial. When prompted to record the name and greeting, you may elect to identify this as the supervisor mailbox. When changing the password, be sure to inform the system supervisor of the number you select.

When you complete the tutorial, press <\*> to prevent it from voicing the next time the box is accessed.

- The system voices the Main menu:

*“To listen to your messages press 1. To send a message press 2. To change your options press 3.”*

- To access the Supervisor menu, **press 6** (this option is not voiced). The system voices the Supervisor menu options:

| <b>Supervisor Menu</b>                       |         |
|--|---------|
| For Mailbox Administration                   | Press 1 |
| For Routing Box Administration               | Press 2 |
| For Question Box Administration              | Press 3 |
| For Port Administration                      | Press 4 |
| To Change the System Broadcast Message       | Press 5 |
| To Change the Voice Mail Day / Night Service | Press 6 |
| To Change the System Time                    | Press 7 |
| To Change the System Date                    | Press 8 |
| To Modify System Parameters                  | Press 9 |
| To Perform First-Time Setup                  | Press 0 |

- From the Supervisors menu, **press 0** to perform first time setup. The system prompts you to enter the **Technician password**. By default, this password is **1234** on Small Office Lite systems or, on Debut units, **the last four digits of the bar code** on the white sticker on the bottom of the unit.
- Follow the prompts and enter the requested information. When you are prompted to indicate the type of phone system with which you are working, enter the number from the following list that corresponds to the phone system:

| Number | Phone System  |
|--------|---|
| 08     | Comdial DigiTech / Impact / DSU - Serial Integration        |
| 76     | Comdial DigiTech / Impact / DSU - Serial Integration - IVPC |
| 11     | Comdial DXP, DXP Plus, FX - Serial Integration              |
| 74     | Comdial DXP, DXP Plus, FX - Serial Integration - IVPC       |

| Number | Phone System  |
|--------|---|
| 22     | Comdial Executech 2000                                      |
| 44     | Comdial Unisyn  |
| 79     | Cortelco Aries  |
| 45     | Encore CX - ECX 1832 / 3672 / 36112                         |
| 77     | Ericsson MD-110   |
| 75     | Fujitsu 9600 with Serial Integration                        |
| 96     | Fujitsu Allegra 26  |
| 78     | Fujitsu Series 3 / Starlog                                  |
| 41     | Fujitsu Starlog   |
| 80     | Harris 20/20  |
| 55     | Isoetec IDS 108 / 228                                       |
| 49     | Isoetec System 96   |
| 30     | ITT / Cortelco System 3100                                  |
| 28     | Iwatsu ADIX   |
| 20     | Iwatsu ZT-D   |
| 94     | Lucent Definity G3 – Calista Box – Vectoring – Bridged Mode |
| 92     | Lucent Definity G3 – VoiceBridge                            |
| 93     | Lucent Definity G3 – VoiceBridge – Vectoring – Bridged Mode |
| 13     | Lucent Merlin II  |
| 34     | Lucent Merlin Legend  |
| 97     | Lucent Partner ACS  |
| 50     | Lucent Partner II   |
| 38     | Lucent Partner Plus   |
| 37     | Lucent System 25  |
| 63     | Lucent System 75  |
| 91     | Lucent System 85 and Definity Generic 2 – VoiceBridge       |
| 31     | Mitel COV with D/42D-SX Voice Boards                        |
| 39     | Mitel SX100 Digital PABX with ONS Integration               |
| 84     | Mitel SX200 Light with COV Integration                      |
| 89     | Mitel SX200 Light with DNIC Integration                     |

| Number | Phone System   |
|--------|--|
| 85     | Mitel SX200 Light with ONS Integration                   |
| 86     | Mitel SX2000 and SX2000 Light with COV Integration       |
| 88     | Mitel SX2000 and SX2000 Light with DNIC Integration      |
| 81     | Mitel SX50 with COV Integration                          |
| 90     | Mitel SX50 with DNIC Integration                         |
| 17     | NEC Electra Professional Level I                         |
| 54     | NEC Electra Professional Level II                        |
| 21     | NEC Mark II  |
| 51     | NEC NEAX-1400 IMS  |
| 73     | NEC NEAX-2000  |
| 35     | NEC NEAX-2400 Serial Integration                         |
| 33     | Nitsuko DSO-1 / ONYX / 124i / 384i                       |
| 72     | Northern Telecom Norstar D42NS                           |
| 27     | Northern Telecom Norstar - With VMI Adapters             |
| 53     | Northern Telecom SL-1 and Meridian-1/SL-1, (with D42-SL) |
| 18     | Panasonic 1232 - Analog                                  |
| 24     | Panasonic DBS  |
| 36     | Panasonic KXT-336  |
| 23     | Panasonic KX-TD 1232 Digital                             |
| 66     | Panther II 820 / 1032 / 2064 Release IV                  |
| 52     | Philips SOPHO-S  |
| 32     | Premier ESP / Intertel GMX                               |
| 47     | Redwood 3.2  |
| 70     | Rolm 9200 BCS / Siemens HCM 200                          |
| 10     | Samsung Prostar 56EX / 120MX / 1224                      |
| 42     | Samsung Prostar DCS - Digital                            |
| 12     | Siemens Saturn I, II, III                                |
| 15     | SMDI Installation Guide / Centrex                        |
| 40     | Southwestern Bell Landmark DKS 308 / 616                 |
| 19     | Sprint Protégé / Macrotel MT360 / 824 KSU                |

| Number | Phone System                       |
|--------|------------------------------------|
| 59     | Tadiran Coral I, II, & III         |
| 68     | Telrad 2464                        |
| 64     | Telrad Digital Key BX, 200 Digital |
| 46     | Toshiba DK-16 / 24 / 56 / 96       |
| 16     | Toshiba DK-280                     |
| 26     | Toshiba Perception E               |
| 95     | Toshiba Perception EX              |
| 57     | Toshiba Perception I & II          |
| 87     | Vodavi DHS                         |
| 43     | Vodavi Infinite DVX1, DVX2, & DVX3 |
| 48     | Vodavi Starplus 2448EX / 4896EX    |
| 58     | Vodavi Starplus 96EX               |
| 14     | Vodavi Starplus Digital            |
| 62     | Win 100D                           |

- Once you enter all necessary information, **press 1** as prompted to reboot the PC. You must allow the system to reboot so it can reset several parameters based on the information you entered. When the system reboots, your call into it is disconnected. Continue with the next procedure.

### 2.7.1.2 Adjusting System Information

You may need to customize certain fields on the System Information screens. Use the following procedure:

- From a telephone, call into voice mail and log into the **supervisor mailbox 70**. The system voices the Main menu:

*“To listen to your messages press 1. To send a message press 2. To change your options press 3.”*



2. To access the Supervisor menu, **press 6** (this option is not voiced). The system voices the Supervisor menu options:

| <b>Supervisor Menu</b>                       |         |
|--|---------|
| For Mailbox Administration                   | Press 1 |
| For Routing Box Administration               | Press 2 |
| For Question Box Administration              | Press 3 |
| For Port Administration                      | Press 4 |
| To Change the System Broadcast Message       | Press 5 |
| To Change the voice mail Day / Night Service | Press 6 |
| To Change the System Time                    | Press 7 |
| To Change the System Date                    | Press 8 |
| To Modify System Parameters                  | Press 9 |
| To Perform First-Time Setup                  | Press 0 |
| To Exit                                      | Press # |

3. From the Supervisors menu, **press 9** to modify system parameters. The system prompts you to enter the **Technician password**. By default, this password is **1234** on Small Office Lite systems or, on Debut units, **the last four digits of the bar code** on the white sticker on the bottom of the unit.
4. At the prompt, enter the number of the parameter you want to change, then, as prompted, the value to which you want to change the parameter. Parameter information is provided in a comprehensive table shown in **section 2.7.2**.

When you complete all modifications, **press #** to return to the Supervisor's menu.

**Note:** Refer to **section 2.7.2** for information on values you can specify for certain parameters and for information on adjusting parameters in the VM.CFG file. For detailed information on each field of System Information screens, refer to the *Installation and Maintenance Manual*.

### 2.7.1.3 Adjusting Routing Box Information

As indicated in **section 2.5.6.2**, you need to adjust Routing Boxes 800, 801, and 821 to include any single-digit call routing options you want to provide to callers. You must also record the necessary greetings for these boxes. Sample Routing box greetings are provided in **section 3.2.1**.

To record Routing box greetings, follow the procedure provided in **section 3.2.2**.

To modify single-digit call routing, you can follow the procedure in **section 3.2.3** or you can use the Teleparameter feature. To use the Teleparameter feature, follow steps 1 through 4 in the previous procedure, referring to the parameter numbers provided in **section 2.7.2**. For detailed information on each field of this screen, refer to the *Installation and Maintenance Manual*.

**Note:** If you enter a parameter number for a parameter that affects a particular box, the system prompts you to enter the **Item number**. The Item number identifies the particular box in which you want to change the parameter. At the Item number prompt, enter the **number of the box**.

**Note:** Refer to **section 2.7.2** for information on values you can specify for certain parameters and for information on adjusting parameters in the VM.CFG file. For detailed information on each field of Routing Box screens, refer to the *Installation and Maintenance Manual*.

### 2.7.1.4 Creating and Adjusting Mailbox Box Information

To create mailboxes on the system, follow the procedure in **section 3.1.1**. Once you create mailboxes, you can make detailed modifications to the box setups using the Teleparameter feature. To use the Teleparameter feature to adjust mailbox information in boxes you have created on the system, follow steps 1 through 4 in the procedure in **section 2.7.1.2**. For specific parameters you can adjust, refer to **section 2.7.2**. For detailed information on each field of these screens, refer to the *Installation and Maintenance Manual*.

**Note:** If you enter a parameter number for a parameter that affects a particular box, the system prompts you to enter the **Item number**. The Item number identifies the particular box in which you want to change the parameter. At the Item number prompt, enter the **number of the box**.

**Note:** Refer to **section 2.7.2** for information on values you can specify for certain parameters and for information on adjusting parameters in the VM.CFG file. For detailed information on each field of Box Setup screens, refer to the *Installation and Maintenance Manual*.

### 2.7.1.5 Creating Other Box Types and Adjusting Information

To create other types of boxes, you must first follow the procedures presented earlier in this document to connect a laptop computer to the Lite system unit and access Box Information setup screens. Once you create the boxes using this technique, you can make detailed modifications to the box setups using the Teleparameter feature. To use the Teleparameter feature to adjust information in boxes already created on the system, follow steps 1 through 4 in the procedure in **section 2.7.1.2**. For specific parameters you can adjust, refer to **section 2.7.2**. For detailed information on each field of these screens, refer to the *Installation and Maintenance Manual*.

**Note:** If you enter a parameter number for a parameter that affects a particular box, the system prompts you to enter the **Item number**. The Item number identifies the particular box in which you want to change the parameter. At the Item number prompt, enter the **number of the box**.

**Note:** Refer to **section 2.7.2** for information on values you can specify for certain parameters and for information on adjusting parameters in the VM.CFG file. For detailed information on each field of Box Setup screens, refer to the *Installation and Maintenance Manual*.

## 2.7.2 Teleparameter Value Tables

The following table identifies all parameters you can adjust using the teleparameter feature and the entries you can make to indicate specific values for each parameter. Refer to information after this table for additional entries you can make in some fields.

| Task                     | Param. Number | Description  | Acceptable Values   | Notes:   |
|--------------------------|---------------|--|---|--|
| Account Number Box Setup | 2700          | Minimum number of digits required for valid entry determination                  | 1 - 9   | A prompt for the Item number refers to the box number. Enter the box number. |
| Account Number Box Setup | 2701          | Maximum number of digits required for valid entry determination                  | 1 - 30  | A prompt for the Item number refers to the box number. Enter the box number. |
| Account Number Box Setup | 2702          | Number of seconds to wait before determining all digits are entered              | 0 - 9   | A prompt for the Item number refers to the box number. Enter the box number. |
| Account Number Box Setup | 2703          | Action to take after maximum retry attempts if invalid account number is entered | 0 = Return<br>1 = Say 'Goodbye'<br>2 = Go to another box<br>3 = Hang up | A prompt for the Item number refers to the box number. Enter the box number. |
| Account Number Box Setup | 2704          | Box associated with parameter 2703   | (Valid mailbox number)  | A prompt for the Item number refers to the box number. Enter the box number. |
| Account Number Box Setup | 2705          | Retry attempts to allow if invalid account number entered                        | 0 - 9   | A prompt for the Item number refers to the box number. Enter the box number. |
| Account Number Box Setup | 2706          | Number of mailbox that owns the Account Number box                               | (Valid mailbox number)  | A prompt for the Item number refers to the box number. Enter the box number. |

| Task                     | Param. Number | Description   | Acceptable Values  | Notes:   |
|--------------------------|---------------|---|--|--|
| Account Number Box Setup | 2707          | Action to take if account number was previously collected during call | 0 = Use the existing account number<br>1 = Ask for a new account number              | A prompt for the Item number refers to the box number. Enter the box number. |
| Account Number Box Setup | 2708          | Repeat number entered for confirmation?                               | 1 = Yes<br>0 = No  | A prompt for the Item number refers to the box number. Enter the box number. |
| Account Number Box Setup | 2001          | Action to take if valid account number is entered                     | 0 = Return<br>1 = Say 'Goodbye'<br>2 = Go to another box<br>3 = Hang up              | A prompt for the Item number refers to the box number. Enter the box number. |
| Account Number Box Setup | 2002          | Box associated with parameter number 2001                             | (Valid box number)   | A prompt for the Item number refers to the box number. Enter the box number. |
| ACD Box Setup            | 2520          | Number of mailbox that owns the ACD box                               | (Valid mailbox number)   | A prompt for the Item number refers to the box number. Enter the box number. |
| ACD Box Setup            | 2521          | Action to take when trying extension                                  | 1 = Blind<br>2 = Wait for answer<br>3 = Screen<br>4 = Wait for ring                  | A prompt for the Item number refers to the box number. Enter the box number. |
| ACD Box Setup            | 2522          | Criteria by which hunt is started                                     | 0 = Start hunting from first agent in group<br>1 = Start hunting from previous agent | A prompt for the Item number refers to the box number. Enter the box number. |
| ACD Box Setup            | 2523          | Number of announcements after which caller is offered other options   | 0 - 99   | A prompt for the Item number refers to the box number. Enter the box number. |
| ACD Box Setup            | 2524          | Rings permitted before no answer determination                        | 0 - 99   | A prompt for the Item number refers to the box number. Enter the box number. |

| Task                 | Param. Number | Description  | Acceptable Values   | Notes:   |
|----------------------|---------------|--|---|--|
| ACD Box Setup        | 2525          | Box default operator during day service                | (Valid mailbox number)  | A prompt for the Item number refers to the box number. Enter the box number.                       |
| ACD Box Setup        | 2526          | Box default operator during night service              | (Valid mailbox number)  | A prompt for the Item number refers to the box number. Enter the box number.                       |
| ACD Box Setup        | 2527          | Action to take if all extensions are busy              | 0 = Queue the call<br>1 = Go to another box                             | A prompt for the Item number refers to the box number. Enter the box number.                       |
| ACD Box Setup        | 2528          | Box associated with parameter 2527                     | (Valid box number)  | A prompt for the Item number refers to the box number. Enter the box number.                       |
| ACD Box Setup        | 2529          | Action to take if caller elects not to remain in queue | 0 = Return<br>1 = Say 'Goodbye'<br>2 = Go to another box<br>3 = Hang up | A prompt for the Item number refers to the box number. Enter the box number.                       |
| ACD Box Setup        | 2530          | Box associated with parameter 2529                     | (Valid box number)  | A prompt for the Item number refers to the box number. Enter the box number.                       |
| ACD Box Setup        | 2531          | If call is queued, state position in line?             | 1 = Yes<br>0 = No   | A prompt for the Item number refers to the box number. Enter the box number.                       |
| ACD Box Setup        | 2501 to 2512  | ACD rotation box members                               | (Valid mailbox numbers)   | A prompt for the Item number refers to the box number. Enter the box number.                       |
| Business Hours Setup | 5042          | Hour day service begins                                | 00-24   | A prompt for the Item number refers to the day of the week. Enter 0 (Sunday) through 6 (Saturday). |

| Task                 | Param. Number | Description  | Acceptable Values | Notes:   |
|----------------------|---------------|--|-------------------|--|
| Business Hours Setup | 5043          | (With parameter 5042)<br>Minute day service begins   | 00 - 59           | A prompt for the Item number refers to the day of the week. Enter 0 (Sunday) through 6 (Saturday). |
| Business Hours Setup | 5044          | Hour day service ends                                | 00 - 24           | A prompt for the Item number refers to the day of the week. Enter 0 (Sunday) through 6 (Saturday). |
| Business Hours Setup | 5045          | (With parameter 5044)<br>Minute day service ends     | 00 - 59           | A prompt for the Item number refers to the day of the week. Enter 0 (Sunday) through 6 (Saturday). |
| Business Hours Setup | 5046          | Hour lunch service begins                            | 00 - 24           | A prompt for the Item number refers to the day of the week. Enter 0 (Sunday) through 6 (Saturday). |
| Business Hours Setup | 5047          | (With parameter 5046)<br>Minute lunch service begins | 00 - 59           | A prompt for the Item number refers to the day of the week. Enter 0 (Sunday) through 6 (Saturday). |
| Business Hours Setup | 5048          | Hour lunch service ends                              | 00 - 24           | A prompt for the Item number refers to the day of the week. Enter 0 (Sunday) through 6 (Saturday). |
| Business Hours Setup | 5049          | (With parameter 5048)<br>Minute lunch service ends   | 00 - 59           | A prompt for the Item number refers to the day of the week. Enter 0 (Sunday) through 6 (Saturday). |

| Task                            | Param. Number | Description  | Acceptable Values                                     | Notes:   |
|---------------------------------|---------------|--|---|--|
| Business Hours Setup            | 5067          | Hour at which greeting is to change to good evening                            | 00 - 24   | A prompt for the Item number refers to the day of the week. Enter 0 (Sunday) through 6 (Saturday). |
| Business Hours Setup            | 5068          | (With parameter 5067)<br>Minute at which greeting is to change to good evening | 00 - 59   | A prompt for the Item number refers to the day of the week. Enter 0 (Sunday) through 6 (Saturday). |
| Call Transfer Information Setup | 5000          | Sequence to initiate an internal transfer                                      | (Refer to technical bulletin and phone documentation) |  |
| Call Transfer Information Setup | 5001          | Sequence to initiate an external transfer                                      | (Refer to technical bulletin and phone documentation) |  |
| Call Transfer Information Setup | 5002          | Sequence to complete an internal transfer                                      | (Refer to technical bulletin and phone documentation) |  |
| Call Transfer Information Setup | 5003          | Sequence to complete an external transfer                                      | (Refer to technical bulletin and phone documentation) |  |
| Call Transfer Information Setup | 5004          | Sequence to return from no answer on an internal call                          | (Refer to technical bulletin and phone documentation) |  |
| Call Transfer Information Setup | 5005          | Sequence to return from no answer on an external call                          | (Refer to technical bulletin and phone documentation) |  |
| Call Transfer Information Setup | 5006          | Sequence to return from busy on an internal call                               | (Refer to technical bulletin and phone documentation) |  |
| Call Transfer Information Setup | 5007          | Sequence to return from busy on an external call                               | (Refer to technical bulletin and phone documentation) |  |
| Call Transfer Information Setup | 5008          | Sequence to return from call screening on an internal call                     | (Refer to technical bulletin and phone documentation) |  |
| Call Transfer Information Setup | 5009          | Sequence to return from call screening on an external call                     | (Refer to technical bulletin and phone documentation) |  |



| Task                            | Param. Number | Description  | Acceptable Values                                     | Notes:   |
|---------------------------------|---------------|--|---|--|
| Call Transfer Information Setup | 5010          | Sequence to transfer an internal 3-way call              | (Refer to technical bulletin and phone documentation) |  |
| Call Transfer Information Setup | 5011          | Sequence to transfer an external 3-way call              | (Refer to technical bulletin and phone documentation) |  |
| Call Transfer Information Setup | 5014          | Should VP system detect dial tone?                       | 1 = Yes<br>0 = No                                     |  |
| Call Transfer Information Setup | 5023          | Confirmation digits meaning 'Yes'                        | (Refer to technical bulletin and phone documentation) |  |
| Call Transfer Information Setup | 5054          | Should VP system use transfer bypass digit?              | 0 = None<br>1 = First<br>2 = Last                     |  |
| Call Transfer Information Setup | 5055          | Maximum time for 3-way call (minutes)                    | 0 - 30  |  |
| Class of Service Setup          | 7000          | Number of days after which Old messages are auto-deleted | 0 - 99  | A prompt for the Item number refers to the Class of Service number. Enter 0 - 7. |
| Class of Service Setup          | 7001          | Number of days after which New messages are auto-deleted | 0 - 99  | A prompt for the Item number refers to the Class of Service number. Enter 0 - 7. |
| Class of Service Setup          | 7002          | Maximum message length (seconds) for a message           | 0 - 999   | A prompt for the Item number refers to the Class of Service number. Enter 0 - 7. |
| Class of Service Setup          | 7003          | Maximum number of messages allowed in mailbox            | 0 - 200   | A prompt for the Item number refers to the Class of Service number. Enter 0 - 7. |
| Class of Service Setup          | 7004          | Maximum greeting length (seconds)                        | 0 - 999   | A prompt for the Item number refers to the Class of Service number. Enter 0 - 7. |

| Task                   | Param. Number | Description  | Acceptable Values | Notes:   |
|------------------------|---------------|--|-------------------|--|
| Class of Service Setup | 7005          | Maximum number of personal greetings allowed                       | 0 - 10            | A prompt for the Item number refers to the Class of Service number. Enter 0 - 7. |
| Class of Service Setup | 7006          | Play menu after greeting to callers?                               | 1 = Yes<br>0 = No | A prompt for the Item number refers to the Class of Service number. Enter 0 - 7. |
| Class of Service Setup | 7007          | Maximum lines allowed to hold for mailbox                          | 0 - 32            | A prompt for the Item number refers to the Class of Service number. Enter 0 - 7. |
| Class of Service Setup | 7008          | Number of times to try extension before returning to queued caller | 0 - 99            | A prompt for the Item number refers to the Class of Service number. Enter 0 - 7. |
| Class of Service Setup | 7009          | Say position in line to calls in queue?                            | 1 = Yes<br>0 = No | A prompt for the Item number refers to the Class of Service number. Enter 0 - 7. |
| Class of Service Setup | 7010          | Access to Group boxes allowed?                                     | 1 = Yes<br>0 = No | A prompt for the Item number refers to the Class of Service number. Enter 0 - 7. |
| Class of Service Setup | 7011          | Supervisor status allowed?   | 1 = Yes<br>0 = No | A prompt for the Item number refers to the Class of Service number. Enter 0 - 7. |
| Class of Service Setup | 7012          | Caller access to P.A. system allowed?                              | 1 = Yes<br>0 = No | A prompt for the Item number refers to the Class of Service number. Enter 0 - 7. |
| Class of Service Setup | 7013          | Dial-out allowed?  | 1 = Yes<br>0 = No | A prompt for the Item number refers to the Class of Service number. Enter 0 - 7. |

| Task                   | Param. Number | Description                                     | Acceptable Values   | Notes:   |
|------------------------|---------------|---|---|--|
| Class of Service Setup | 7014          | Faxmail receipt allowed?                        | 1 = Yes<br>0 = No   | A prompt for the Item number refers to the Class of Service number. Enter 0 - 7. |
| Class of Service Setup | 7015          | Default operator box during day service hours   | (Valid mailbox number)  | A prompt for the Item number refers to the Class of Service number. Enter 0 - 7. |
| Class of Service Setup | 7016          | Default operator box during night service hours | (Valid mailbox number)  | A prompt for the Item number refers to the Class of Service number. Enter 0 - 7. |
| Class of Service Setup | 7017          | When exiting open mailbox, go to box #          | (Valid box number)  | A prompt for the Item number refers to the Class of Service number. Enter 0 - 7. |
| Class of Service Setup | 7018          | Digits callers can press while holding          | 1 - 9, #  | A prompt for the Item number refers to the Class of Service number. Enter 0 - 7. |
| Class of Service Setup | 7020 to 7029  | Restricted outcalling numbers                   | (Any digits)  | A prompt for the Item number refers to the Class of Service number. Enter 0 - 7. |
| Directory Box Setup    | 2001          | Action to take if no digits are dialed          | 0 = Return<br>1 = Say 'Goodbye'<br>2 = Go to another box<br>3 = Hang up | A prompt for the Item number refers to the box number. Enter the box number.     |
| Directory Box Setup    | 2002          | Box associated with parameter 2001              | (Valid box number)  | A prompt for the Item number refers to the box number. Enter the box number.     |
| Directory Box Setup    | 2600          | Number of time to play greeting                 | 1 - 3   | A prompt for the Item number refers to the box number. Enter the box number.     |

| Task                      | Param. Number | Description  | Acceptable Values   | Notes:   |
|---------------------------|---------------|--|---|--|
| Directory Box Setup       | 2601          | Box associated with parameter 2602   | (Valid box number)  | A prompt for the Item number refers to the box number. Enter the box number. |
| Directory Box Setup       | 2602          | Action to take if requested name is not found  | 0 = Return<br>1 = Say 'Goodbye'<br>2 = Go to another box<br>3 = Hang up | A prompt for the Item number refers to the box number. Enter the box number. |
| Directory Box Setup       | 2603          | Say box number before transferring call?   | 1 = Yes<br>0 = No   | A prompt for the Item number refers to the box number. Enter the box number. |
| Directory Box Setup       | 2604          | Allow callers to hear complete directory listing?                                      | 1 = Yes<br>0 = No   | A prompt for the Item number refers to the box number. Enter the box number. |
| Directory Box Setup       | 2605          | Maximum number of digits to collect from callers                                       | 1 - 9   | A prompt for the Item number refers to the box number. Enter the box number. |
| General Information Setup | 5017          | Fast-forwarded / rewind seconds  | 0 - 10  |  |
| General Information Setup | 5024          | Technician password  | Up to 10 digits   |  |
| General Information Setup | 5025          | Customer password  | Up to 10 digits   |  |
| General Information Setup | 5027          | Digits needed to get line for external call  | (Refer to technical bulletin and phone documentation)                   |  |
| General Information Setup | 5053          | Store call log to:   | 0 = None<br>1 = File<br>2 = Printer                                     |  |
| General Information Setup | 5056          | (With parameter 5057)<br>Maximum number of minutes call can last before being rerouted | 0 - 30  |  |

| Task                      | Param. Number | Description   | Acceptable Values   | Notes:   |
|---------------------------|---------------|---|---------------------|--|
| General Information Setup | 5057          | (With parameter 5056) Box to which calls are re-routed                | (Valid box number)  |  |
| General Information Setup | 5065          | Exit to DOS hour  | 00-23               |  |
| General Information Setup | 5066          | Exit to DOS minutes   | 00-59               |  |
| Group Box Setup           | 2800          | Maximum length of a message (seconds) that can be sent to this box    | 10 - 999            | A prompt for the Item number refers to the box number. Enter the box number.   |
| Group Box Setup           | 2801 to 2850  | Group box members   | (Valid box numbers) | A prompt for the Item number refers to the box number. Enter the box number.   |
| Holiday Schedule Setup    | 5050          | (With parameter 5051) Holiday month                                   | 00-12               | A prompt for the Item number refers to the holiday number. Enter 1 through 20. |
| Holiday Schedule Setup    | 5051          | (With parameter 5050) Holiday date                                    | 01-31               | A prompt for the Item number refers to the holiday number. Enter 1 through 20. |
| Holiday Schedule Setup    | 5052          | Box to which calls are routed during holiday                          | (Valid box number)  | A prompt for the Item number refers to the holiday number. Enter 1 through 20. |
| Line Information Setup    | 1000          | Box to which calls on this line are routed during day service hours   | (Valid box number)  | A prompt for the Item number refers to the line number. Enter the line number. |
| Line Information Setup    | 1001          | Box to which calls on this line are routed during night service hours | (Valid box number)  | A prompt for the Item number refers to the line number. Enter the line number. |

| Task                   | Param. Number | Description   | Acceptable Values  | Notes:   |
|------------------------|---------------|---|--------------------|--|
| Line Information Setup | 1002          | Box to which calls on this line are routed during lunch service hours | (Valid box number) | A prompt for the Item number refers to the line number. Enter the line number. |
| Line Information Setup | 1003          | Rings before call is answered during day service hours                | 1 - 99             | A prompt for the Item number refers to the line number. Enter the line number. |
| Line Information Setup | 1004          | Rings before call is answered during night service hours              | 1 - 99             | A prompt for the Item number refers to the line number. Enter the line number. |
| Line Information Setup | 1005          | Rings before call is answered during lunch service hours              | 1 - 99             | A prompt for the Item number refers to the line number. Enter the line number. |
| Line Information Setup | 1006          | Outgoing calls allowed on this line?                                  | 1 = Yes<br>0 = No  | A prompt for the Item number refers to the line number. Enter the line number. |
| Line Information Setup | 1007          | Line belongs to Line Group A?   | 1 = Yes<br>0 = No  | A prompt for the Item number refers to the line number. Enter the line number. |
| Line Information Setup | 1008          | Line belongs to Line Group B?   | 1 = Yes<br>0 = No  | A prompt for the Item number refers to the line number. Enter the line number. |
| Line Information Setup | 1009          | Line belongs to Line Group C?   | 1 = Yes<br>0 = No  | A prompt for the Item number refers to the line number. Enter the line number. |
| Line Information Setup | 1010          | Line belongs to Line Group D?   | 1 = Yes<br>0 = No  | A prompt for the Item number refers to the line number. Enter the line number. |

| Task          | Param. Number | Description  | Acceptable Values   | Notes:   |
|---------------|---------------|--|---|--|
| Mailbox Setup | 2000          | Mailbox owner's last name                            | (Digits that will allow the Dial-by-Name directory feature access this mailbox) | A prompt for the Item number refers to the box number. Enter the box number. |
| Mailbox Setup | 2001          | Action to be taken after caller leaves message       | 0 = Return<br>1 = Say 'Goodbye'<br>2 = Go to another box<br>3 = Hang up         | A prompt for the Item number refers to the box number. Enter the box number. |
| Mailbox Setup | 2002          | Box associated with parameter 2001                   | (Valid box number)  | A prompt for the Item number refers to the box number. Enter the box number. |
| Mailbox Setup | 2100          | Mailbox password                                     | (Up to maximum digits specified during setup)                                   | A prompt for the Item number refers to the box number. Enter the box number. |
| Mailbox Setup | 2101          | Sequence to turn on message waiting lamp             | (See technical bulletin or phone documentation)                                 | A prompt for the Item number refers to the box number. Enter the box number. |
| Mailbox Setup | 2102          | Sequence to turn off message waiting lamp            | (See technical bulletin or phone documentation)                                 | A prompt for the Item number refers to the box number. Enter the box number. |
| Mailbox Setup | 2110          | Box associated with parameter 2111                   | (Valid box number)  | A prompt for the Item number refers to the box number. Enter the box number. |
| Mailbox Setup | 2111          | Action to be taken if caller chooses "other options" | 0 = Return<br>1 = Say 'Goodbye'<br>2 = Go to another box<br>3 = Hang up         | A prompt for the Item number refers to the box number. Enter the box number. |

| Task          | Param. Number | Description  | Acceptable Values  | Notes:   |
|---------------|---------------|--|--|--|
| Mailbox Setup | 2112          | Mailbox has access to only Hotel guest privileges?   | 1 = Yes<br>0 = No  | A prompt for the Item number refers to the box number. Enter the box number.<br><br>You can modify only one personal distribution list for the mailbox using the Teleparameter feature |
| Mailbox Setup | 2113          | Class of service assigned to mailbox   | 0 - 7  | A prompt for the Item number refers to the box number. Enter the box number.   |
| Mailbox Setup | 2114          | Mailbox to which this mailbox is a client, if this is a restricted mailbox                           | (Valid mailbox number)   | A prompt for the Item number refers to the box number. Enter the box number.   |
| Mailbox Setup | 2115          | Language in which greeting is to play if call is via D.I.D   | 0 - 9  | A prompt for the Item number refers to the box number. Enter the box number.   |
| Mailbox Setup | 2120          | Type of transfer   | 0 = None<br>1 = Blind<br>2 = Wait for answer<br>3 = Screen<br>4 = Wait for ring                                      | A prompt for the Item number refers to the box number. Enter the box number.   |
| Mailbox Setup | 2122          | Number of rings within which called party must answer before system determines a no answer condition | 0 = Always<br>1 = Day only<br>2 = Night only<br>3 = Schedule A<br>4 = Schedule B<br>5 = Schedule C<br>6 = Schedule D | A prompt for the Item number refers to the box number. Enter the box number.   |
| Mailbox Setup | 2122          | 3-way calling used   | 0 = Always<br>1 = Day only<br>2 = Night only<br>3 = Schedule A<br>4 = Schedule B<br>5 = Schedule C<br>6 = Schedule D | A prompt for the Item number refers to the box number. Enter the box number.   |



| Task          | Param. Number | Description  | Acceptable Values  | Notes:   |
|---------------|---------------|--|--|--|
| Mailbox Setup | 2123          | Call transfer schedule   | 0 = Always<br>1 = Day only<br>2 = Night only<br>3 = Schedule A<br>4 = Schedule B<br>5 = Schedule C<br>6 = Schedule D | A prompt for the Item number refers to the box number. Enter the box number. |
| Mailbox Setup | 2124          | Caller's name voiced upon pickup?  | 1 = Yes<br>0 = No  | A prompt for the Item number refers to the box number. Enter the box number. |
| Mailbox Setup | 2125          | Record conversation?   | 1 = Yes<br>0 = No  | A prompt for the Item number refers to the box number. Enter the box number. |
| Mailbox Setup | 2126          | Transfer destination   | Extension number   | A prompt for the Item number refers to the box number. Enter the box number. |
| Mailbox Setup | 2130          | (With parameter 2134)<br>Type of pager                                       | 0 = None<br>1 = Tone-only pager (no display)<br>2 = Display pager  | A prompt for the Item number refers to the box number. Enter the box number. |
| Mailbox Setup | 2131          | (With parameter 2134)<br>Minutes between calls to pager                      | 00 - 20  | A prompt for the Item number refers to the box number. Enter the box number. |
| Mailbox Setup | 2132          | (With parameter 2134)<br>Number of times to call pager                       | 00 - 99  | A prompt for the Item number refers to the box number. Enter the box number. |
| Mailbox Setup | 2133          | (With parameter 2134)<br>Schedule during which calls should be sent to pager | 0 = Always<br>1 = Day only<br>2 = Night only<br>3 = Schedule A<br>4 = Schedule B<br>5 = Schedule C<br>6 = Schedule D | A prompt for the Item number refers to the box number. Enter the box number. |

| Task          | Param. Number | Description   | Acceptable Values  | Notes:   |
|---------------|---------------|---|--|--|
| Mailbox Setup | 2134          | Mailbox owner's pager number  | (Pager number)   | A prompt for the Item number refers to the box number. Enter the box number.   |
| Mailbox Setup | 2141          | Action to be taken after personal greeting is played                                  | 0 = Wait for a digit<br>1 = Begin recording a message<br>2 = Page the mailbox owner<br>3 = Record a message, then page the mailbox owner | A prompt for the Item number refers to the box number. Enter the box number.   |
| Mailbox Setup | 2142          | Hours after which messages are to be auto-forwarded                                   | 0 - 999  | A prompt for the Item number refers to the box number. Enter the box number.   |
| Mailbox Setup | 2143          | (With parameter 2142) Box to which new messages are to be auto-forwarded              | (Valid mailbox number)   | A prompt for the Item number refers to the box number. Enter the box number.   |
| Mailbox Setup | 2144          | (With parameters 2142 and 2143) Schedule during which auto-forwarding is to be active | 0 = Always<br>1 = Day only<br>2 = Night only<br>3 = Schedule A<br>4 = Schedule B<br>5 = Schedule C<br>6 = Schedule D                     | A prompt for the Item number refers to the box number. Enter the box number.   |
| Mailbox Setup | 2150          | Number to call for message delivery   | (Phone or beeper number)   | A prompt for the Item number refers to the box number. Enter the box number.<br><br>You can modify only one message delivery set up for the mailbox using the Teleparameter feature. |

| Task          | Param. Number | Description   | Acceptable Values  | Notes:   |
|---------------|---------------|---|--|--|
| Mailbox Setup | 2151          | (With parameter 5150)<br>Number of times to run the message delivery cycle. | 0 - 99   | A prompt for the Item number refers to the box number. Enter the box number.<br><br>You can modify only one message delivery set up for the mailbox using the Teleparameter feature. |
| Mailbox Setup | 2152          | (With parameter 2150)<br>Number of times number is to be called             | 0 - 99   | A prompt for the Item number refers to the box number. Enter the box number.<br><br>You can modify only one message delivery set up for the mailbox using the Teleparameter feature. |
| Mailbox Setup | 2153          | (With parameter 5152)<br>Minutes in between calls to number                 | 2 - 99   | A prompt for the Item number refers to the box number. Enter the box number.<br><br>You can modify only one message delivery set up for the mailbox using the Teleparameter feature. |
| Mailbox Setup | 2154          | (With parameter 5150)<br>Schedule during which message delivery is active   | 0 = Always<br>1 = Day only<br>2 = Night only<br>3 = Schedule A<br>4 = Schedule B<br>5 = Schedule C<br>6 = Schedule D | A prompt for the Item number refers to the box number. Enter the box number.<br><br>You can modify only one message delivery set up for the mailbox using the Teleparameter feature. |

| Task                       | Param. Number | Description   | Acceptable Values   | Notes:   |
|----------------------------|---------------|---|---|--|
| Mailbox Setup              | 2159          | Personal distribution list 1 enabled for mailbox?       | 1 = Yes<br>0 = No   | A prompt for the Item number refers to the box number. Enter the box number.<br><br>You can modify only one personal distribution list for the mailbox using the Teleparameter feature |
| Mailbox Setup              | 2160 to 2179  | Personal distribution list 1 members                    | (Valid mailbox numbers)   | A prompt for the Item number refers to the box number. Enter the box number.<br><br>You can modify only one personal distribution list for the mailbox using the Teleparameter feature |
| Other Customizations Setup | 5018          | Maximum box length caller can dial                      | 2 - 4   |  |
| Other Customizations Setup | 5019          | Seconds of initial pause before main greeting is played | 0 - 10  |  |
| Other Customizations Setup | 5020          | When VP system should play time and date                | 0 = When caller asks<br>1 = Before each message<br>2 = After each message |  |
| Other Customizations Setup | 5021          | Play called party's name when call is answered?         | 1 = Yes<br>0 = No   |  |
| Other Customizations Setup | 5022          | Announce call when call is answered?                    | 1 = Yes<br>0 = No   |  |
| Other Customizations Setup | 5076 to 5079  | Custom field (use under direction of technical support) | ---   |  |
| Other Customizations Setup | 5086 to 5089  | Debug field (use under direction of technical support)  | ---   |  |

| Task               | Param. Number | Description  | Acceptable Values   | Notes:   |
|--------------------|---------------|--|---|--|
| Question Box Setup | 2001          | Action to take after questions are answered                | 0 = Return<br>1 = Say 'Goodbye'<br>2 = Go to another box<br>3 = Hang up | A prompt for the Item number refers to the box number. Enter the box number. |
| Question Box Setup | 2002          | Box associated with parameter 2404                         | (Valid box number)  | A prompt for the Item number refers to the box number. Enter the box number. |
| Question Box Setup | 2400          | Number of mailbox that owns the Question box               | (Valid mailbox number)  | A prompt for the Item number refers to the box number. Enter the box number. |
| Question Box Setup | 2401          | Replay digit answers for verification?                     | 1 = Yes<br>0 = No   | A prompt for the Item number refers to the box number. Enter the box number. |
| Question Box Setup | 2402          | Voice answers? (versus digit)                              | 1 = Yes<br>0 = No   | A prompt for the Item number refers to the box number. Enter the box number. |
| Question Box Setup | 2403          | Trigger owner mailbox notification of answers in this box? | 1 = Yes<br>0 = No   | A prompt for the Item number refers to the box number. Enter the box number. |
| Question Box Setup | 2404          | Digits caller can press to exit this box                   | 0 - 9, *, #   | A prompt for the Item number refers to the box number. Enter the box number. |
| Question Box Setup | 2410          | Answer type for Question 10                                | 0 = Voice<br>1 = Digits   | A prompt for the Item number refers to the box number. Enter the box number. |
| Question Box Setup | 2411          | Answer type for Question 1                                 | 0 = Voice<br>1 = Digits   | A prompt for the Item number refers to the box number. Enter the box number. |

| Task               | Param. Number | Description  | Acceptable Values       | Notes:   |
|--------------------|---------------|--|-------------------------|--|
| Question Box Setup | 2412          | Answer type for Question 2   | 0 = Voice<br>1 = Digits | A prompt for the Item number refers to the box number. Enter the box number. |
| Question Box Setup | 2413          | Answer type for Question 3   | 0 = Voice<br>1 = Digits | A prompt for the Item number refers to the box number. Enter the box number. |
| Question Box Setup | 2414          | Answer type for Question 4   | 0 = Voice<br>1 = Digits | A prompt for the Item number refers to the box number. Enter the box number. |
| Question Box Setup | 2415          | Answer type for Question 5   | 0 = Voice<br>1 = Digits | A prompt for the Item number refers to the box number. Enter the box number. |
| Question Box Setup | 2416          | Answer type for Question 6   | 0 = Voice<br>1 = Digits | A prompt for the Item number refers to the box number. Enter the box number. |
| Question Box Setup | 2417          | Answer type for Question 7   | 0 = Voice<br>1 = Digits | A prompt for the Item number refers to the box number. Enter the box number. |
| Question Box Setup | 2418          | Answer type for Question 8   | 0 = Voice<br>1 = Digits | A prompt for the Item number refers to the box number. Enter the box number. |
| Question Box Setup | 2419          | Answer type for Question 9   | 0 = Voice<br>1 = Digits | A prompt for the Item number refers to the box number. Enter the box number. |
| Question Box Setup | 2420          | If the answer type is digits, minimum number of digits that must be entered for valid answer to question 10. | 1 - 999                 | A prompt for the Item number refers to the box number. Enter the box number. |

| Task               | Param. Number | Description   | Acceptable Values | Notes:   |
|--------------------|---------------|---|-------------------|--|
| Question Box Setup | 2421          | If the answer type is digits, minimum number of digits that must be entered for valid answer to question 1. | 1 - 999           | A prompt for the Item number refers to the box number. Enter the box number. |
| Question Box Setup | 2422          | If the answer type is digits, minimum number of digits that must be entered for valid answer to question 2. | 1 - 999           | A prompt for the Item number refers to the box number. Enter the box number. |
| Question Box Setup | 2423          | If the answer type is digits, minimum number of digits that must be entered for valid answer to question 3. | 1 - 999           | A prompt for the Item number refers to the box number. Enter the box number. |
| Question Box Setup | 2424          | If the answer type is digits, minimum number of digits that must be entered for valid answer to question 4. | 1 - 999           | A prompt for the Item number refers to the box number. Enter the box number. |
| Question Box Setup | 2425          | If the answer type is digits, minimum number of digits that must be entered for valid answer to question 5. | 1 - 999           | A prompt for the Item number refers to the box number. Enter the box number. |
| Question Box Setup | 2426          | If the answer type is digits, minimum number of digits that must be entered for valid answer to question 6. | 1 - 999           | A prompt for the Item number refers to the box number. Enter the box number. |
| Question Box Setup | 2427          | If the answer type is digits, minimum number of digits that must be entered for valid answer to question 7. | 1 - 999           | A prompt for the Item number refers to the box number. Enter the box number. |
| Question Box Setup | 2428          | If the answer type is digits, minimum number of digits that must be entered for valid answer to question 8. | 1 - 999           | A prompt for the Item number refers to the box number. Enter the box number. |
| Question Box Setup | 2429          | If the answer type is digits, minimum number of digits that must be entered for valid answer to question 9. | 1 - 999           | A prompt for the Item number refers to the box number. Enter the box number. |

| Task               | Param. Number | Description   | Acceptable Values | Notes:   |
|--------------------|---------------|---|-------------------|--|
| Question Box Setup | 2430          | If the answer type is digits, maximum number of digits that can be entered for valid answer to question 10. | 1 - 999           | A prompt for the Item number refers to the box number. Enter the box number. |
| Question Box Setup | 2431          | If the answer type is digits, maximum number of digits that can be entered for valid answer to question 1.  | 1 - 999           | A prompt for the Item number refers to the box number. Enter the box number. |
| Question Box Setup | 2432          | If the answer type is digits, maximum number of digits that can be entered for valid answer to question 2.  | 1 - 999           | A prompt for the Item number refers to the box number. Enter the box number. |
| Question Box Setup | 2433          | If the answer type is digits, maximum number of digits that can be entered for valid answer to question 3.  | 1 - 999           | A prompt for the Item number refers to the box number. Enter the box number. |
| Question Box Setup | 2434          | If the answer type is digits, maximum number of digits that can be entered for valid answer to question 4.  | 1 - 999           | A prompt for the Item number refers to the box number. Enter the box number. |
| Question Box Setup | 2435          | If the answer type is digits, maximum number of digits that can be entered for valid answer to question 5.  | 1 - 999           | A prompt for the Item number refers to the box number. Enter the box number. |
| Question Box Setup | 2436          | If the answer type is digits, maximum number of digits that can be entered for valid answer to question 6.  | 1 - 999           | A prompt for the Item number refers to the box number. Enter the box number. |
| Question Box Setup | 2437          | If the answer type is digits, maximum number of digits that can be entered for valid answer to question 7.  | 1 - 999           | A prompt for the Item number refers to the box number. Enter the box number. |
| Question Box Setup | 2438          | If the answer type is digits, maximum number of digits that can be entered for valid answer to question 8.  | 1 - 999           | A prompt for the Item number refers to the box number. Enter the box number. |



| Task               | Param. Number | Description  | Acceptable Values | Notes:   |
|--------------------|---------------|--|-------------------|--|
| Question Box Setup | 2439          | If the answer type is digits, maximum number of digits that can be entered for valid answer to question 9.                           | 1 - 999           | A prompt for the Item number refers to the box number. Enter the box number. |
| Question Box Setup | 2440          | Number of seconds of silence before VP system determines caller has finished entering digits or speaking the answer for question 10. | 1 - 99            | A prompt for the Item number refers to the box number. Enter the box number. |
| Question Box Setup | 2441          | Number of seconds of silence before VP system determines caller has finished entering digits or speaking the answer for question 1.  | 1 - 99            | A prompt for the Item number refers to the box number. Enter the box number. |
| Question Box Setup | 2442          | Number of seconds of silence before VP system determines caller has finished entering digits or speaking the answer for question 2.  | 1 - 99            | A prompt for the Item number refers to the box number. Enter the box number. |
| Question Box Setup | 2443          | Number of seconds of silence before VP system determines caller has finished entering digits or speaking the answer for question 3.  | 1 - 99            | A prompt for the Item number refers to the box number. Enter the box number. |
| Question Box Setup | 2444          | Number of seconds of silence before VP system determines caller has finished entering digits or speaking the answer for question 4.  | 1 - 99            | A prompt for the Item number refers to the box number. Enter the box number. |
| Question Box Setup | 2445          | Number of seconds of silence before VP system determines caller has finished entering digits or speaking the answer for question 5.  | 1 - 99            | A prompt for the Item number refers to the box number. Enter the box number. |

| Task               | Param. Number | Description   | Acceptable Values   | Notes:   |
|--------------------|---------------|---|---|--|
| Question Box Setup | 2446          | Number of seconds of silence before VP system determines caller has finished entering digits or speaking the answer for question 6. | 1 - 99  | A prompt for the Item number refers to the box number. Enter the box number. |
| Question Box Setup | 2447          | Number of seconds of silence before VP system determines caller has finished entering digits or speaking the answer for question 7. | 1 - 99  | A prompt for the Item number refers to the box number. Enter the box number. |
| Question Box Setup | 2448          | Number of seconds of silence before VP system determines caller has finished entering digits or speaking the answer for question 8. | 1 - 99  | A prompt for the Item number refers to the box number. Enter the box number. |
| Question Box Setup | 2449          | Number of seconds of silence before VP system determines caller has finished entering digits or speaking the answer for question 9. | 1 - 99  | A prompt for the Item number refers to the box number. Enter the box number. |
| Routing Box Setup  | 2001          | Action to take if no digits dialed  | 0 = Return<br>1 = Say 'Goodbye'<br>2 = Go to another box<br>3 = Hang up |  |
| Routing Box Setup  | 2002          | Box associated with parameter 2001  | (Valid box number)  |  |
| Routing Box Setup  | 2300          | Single-digit dialing destination for digit 0  | (Valid box number)  | A prompt for the Item number refers to the box number. Enter the box number. |
| Routing Box Setup  | 2301          | Single-digit dialing destination for digit 1  | (Valid box number)  | A prompt for the Item number refers to the box number. Enter the box number. |
| Routing Box Setup  | 2302          | Single-digit dialing destination for digit 2  | (Valid box number)  | A prompt for the Item number refers to the box number. Enter the box number. |

| Task              | Param. Number | Description                                  | Acceptable Values  | Notes:   |
|-------------------|---------------|--|--------------------|--|
| Routing Box Setup | 2303          | Single-digit dialing destination for digit 3 | (Valid box number) | A prompt for the Item number refers to the box number. Enter the box number. |
| Routing Box Setup | 2304          | Single-digit dialing destination for digit 4 | (Valid box number) | A prompt for the Item number refers to the box number. Enter the box number. |
| Routing Box Setup | 2305          | Single-digit dialing destination for digit 5 | (Valid box number) | A prompt for the Item number refers to the box number. Enter the box number. |
| Routing Box Setup | 2306          | Single-digit dialing destination for digit 6 | (Valid box number) | A prompt for the Item number refers to the box number. Enter the box number. |
| Routing Box Setup | 2307          | Single-digit dialing destination for digit 7 | (Valid box number) | A prompt for the Item number refers to the box number. Enter the box number. |
| Routing Box Setup | 2308          | Single-digit dialing destination for digit 8 | (Valid box number) | A prompt for the Item number refers to the box number. Enter the box number. |
| Routing Box Setup | 2309          | Single-digit dialing destination for digit 9 | (Valid box number) | A prompt for the Item number refers to the box number. Enter the box number. |
| Routing Box Setup | 2310          | Single-digit dialing destination for *       | (Valid box number) | A prompt for the Item number refers to the box number. Enter the box number. |
| Routing Box Setup | 2311          | Single-digit dialing destination for #       | (Valid box number) | A prompt for the Item number refers to the box number. Enter the box number. |

| Task                        | Param. Number | Description   | Acceptable Values  | Notes:   |
|-----------------------------|---------------|---|--|--|
| Routing Box Setup           | 2312          | Single-digit dialing destination for non-DTMF digit (voice) | (Valid box number)   | A prompt for the Item number refers to the box number. Enter the box number. |
| Routing Box Setup           | 2313          | Number of mailbox that owns the Routing box                 | (Valid box number)   |  |
| Routing Box Setup           | 2314          | Box to which calls are transferred if invalid digits dialed | (Valid box number)   | A prompt for the Item number refers to the box number. Enter the box number. |
| Routing Box Setup           | 2315          | Number of times to play greeting                            | 1 - 3  |  |
| Routing Box Setup           | 2316          | Seconds to wait for a digit                                 | 0 - 9  |  |
| Routing Box Setup           | 2317          | Basis used to route call                                    | 0 = Digits dialed<br>1 = Day of week<br>2 = Sequence number<br>3 = Database lookup<br>4 = Day or Night service | A prompt for the Item number refers to the box number. Enter the box number. |
| Routing Box Setup           | 2318          | When digits received, wait for more digits?                 | 1 = Yes<br>0 = No  | A prompt for the Item number refers to the box number. Enter the box number. |
| Technical Information Setup | 5012          | Hookflash length (milliseconds)                             | 100 - 5000   |  |
| Technical Information Setup | 5013          | Pause length (milliseconds)                                 | 10 - 5000  |  |
| Technical Information Setup | 5015          | Seconds of silence before VP system ends recording          | 0 - 99   |  |
| Technical Information Setup | 5016          | Seconds of non-silence before VP system ends recording      | 0 - 99   |  |
| Technical Information Setup | 5026          | Disconnect digit sequence                                   | (Refer to technical bulletin and phone documentation)  |  |

| Task                        | Param. Number | Description  | Acceptable Values            | Notes: |
|-----------------------------|---------------|--|------------------------------|--------|
| Technical Information Setup | 5063          | Hour at which system automatically updates MWI                         | 00 - 23                      |        |
| Technical Information Setup | 5064          | (With parameter 5063) Minute at which system automatically updates MWI | 00 - 59                      |        |
| VM.CMG Setup                | 9001          | transbypass=   | See the Installation Manual. |        |
| VM.CMG Setup                | 9003          | dtmfon=  | See the Installation Manual. |        |
| VM.CMG Setup                | 9004          | ignorenonsilence   | See the Installation Manual. |        |
| VM.CMG Setup                | 9007          | internal=  | See the Installation Manual. |        |
| VM.CMG Setup                | 9011          | pagetime=  | See the Installation Manual. |        |
| VM.CMG Setup                | 9012          | pagerretry=  | See the Installation Manual. |        |
| VM.CMG Setup                | 9014          | maxpasswordlength=   | See the Installation Manual. |        |
| VM.CMG Setup                | 9015          | greetsil=  | See the Installation Manual. |        |
| VM.CMG Setup                | 9017          | notifyreps=  | See the Installation Manual. |        |
| VM.CMG Setup                | 9019          | interdigit=  | See the Installation Manual. |        |
| VM.CMG Setup                | 9023          | detectpulse  | See the Installation Manual. |        |
| VM.CMG Setup                | 9025          | auditdatabase  | See the Installation Manual. |        |
| VM.CMG Setup                | 9026          | responsetime=  | See the Installation Manual. |        |
| VM.CMG Setup                | 9099          | pa.init=   | See the Installation Manual. |        |
| VM.CMG Setup                | 9100          | pa.cancel=   | See the Installation Manual. |        |
| VM.CMG Setup                | 9101          | tutorialreps=  | See the Installation Manual. |        |
| VM.CMG Setup                | 9102          | pa.repeats=  | See the Installation Manual. |        |

| Task         | Param. Number | Description        | Acceptable Values            | Notes: |
|--------------|---------------|--------------------|------------------------------|--------|
| VM.CMG Setup | 9103          | novideomemory      | See the Installation Manual. |        |
| VM.CMG Setup | 9104          | offhookdelay=      | See the Installation Manual. |        |
| VM.CMG Setup | 9105          | hardwareint=       | See the Installation Manual. |        |
| VM.CMG Setup | 9106          | ringon=            | See the Installation Manual. |        |
| VM.CMG Setup | 9107          | minimummessage=    | See the Installation Manual. |        |
| VM.CMG Setup | 9108          | maxinactive=       | See the Installation Manual. |        |
| VM.CMG Setup | 9109          | maxlockup=         | See the Installation Manual. |        |
| VM.CMG Setup | 9118          | languages=         | See the Installation Manual. |        |
| VM.CMG Setup | 9120          | dtmfsendon=        | See the Installation Manual. |        |
| VM.CMG Setup | 9121          | dtmfsendoff=       | See the Installation Manual. |        |
| VM.CMG Setup | 9122          | pa.busy=           | See the Installation Manual. |        |
| VM.CMG Setup | 9123          | lunchoperatorisday | See the Installation Manual. |        |
| VM.CMG Setup | 9124          | samplingrate=      | See the Installation Manual. |        |
| VM.CMG Setup | 9125          | databaseline=      | See the Installation Manual. |        |
| VM.CMG Setup | 9126          | ignoredisconnects  | See the Installation Manual. |        |
| VM.CMG Setup | 9127          | nonamettransfer    | See the Installation Manual. |        |
| VM.CMG Setup | 9135          | norecordbeep       | See the Installation Manual. |        |
| VM.CMG Setup | 9144          | repeatmw=          | See the Installation Manual. |        |
| VM.CMG Setup | 9146          | deleteafterfwd     | See the Installation Manual. |        |
| VM.CMG Setup | 9150          | remotepause=       | See the Installation Manual. |        |

| Task         | Param. Number | Description             | Acceptable Values            | Notes: |
|--------------|---------------|-------------------------|------------------------------|--------|
| VM.CMG Setup | 9160          | ringreset=              | See the Installation Manual. |        |
| VM.CMG Setup | 9161          | notifyrings=            | See the Installation Manual. |        |
| VM.CMG Setup | 9162          | assumepageconfirm       | See the Installation Manual. |        |
| VM.CMG Setup | 9163          | assumehold=             | See the Installation Manual. |        |
| VM.CMG Setup | 9165          | externalfax             | See the Installation Manual. |        |
| VM.CMG Setup | 9166          | faxtimeout=             | See the Installation Manual. |        |
| VM.CMG Setup | 9167          | nopcbeep                | See the Installation Manual. |        |
| VM.CMG Setup | 9174          | cdspeed=                | See the Installation Manual. |        |
| VM.CMG Setup | 9182          | ignoreinitialdisconnect | See the Installation Manual. |        |
| VM.CMG Setup | 9190          | lineaccessontransfer    | See the Installation Manual. |        |
| VM.CMG Setup | 9192          | 24hourclockdisplay      | See the Installation Manual. |        |
| VM.CMG Setup | 9203          | linesconnected=         | See the Installation Manual. |        |
| VM.CMG Setup | 9206          | qboxposconfirm          | See the Installation Manual. |        |
| VM.CMG Setup | 9207          | qboxdataprint           | See the Installation Manual. |        |
| VM.CMG Setup | 9208          | qboxarchive             | See the Installation Manual. |        |
| VM.CMG Setup | 9209          | pagerprefix=            | See the Installation Manual. |        |
| VM.CMG Setup | 9210          | pagerappend=            | See the Installation Manual. |        |
| VM.CMG Setup | 9214          | omitgroupsender         | See the Installation Manual. |        |
| VM.CMG Setup | 9216          | pagertrail=             | See the Installation Manual. |        |
| VM.CMG Setup | 9218          | longhookflash=          | See the Installation Manual. |        |

| Task         | Param. Number | Description           | Acceptable Values            | Notes: |
|--------------|---------------|-----------------------|------------------------------|--------|
| VM.CMG Setup | 9219          | cp.dialtone=          | See the Installation Manual. |        |
| VM.CMG Setup | 9220          | cp.busy=              | See the Installation Manual. |        |
| VM.CMG Setup | 9221          | cp.invalid=           | See the Installation Manual. |        |
| VM.CMG Setup | 9222          | cp.dnd=               | See the Installation Manual. |        |
| VM.CMG Setup | 9223          | cp.ans=               | See the Installation Manual. |        |
| VM.CMG Setup | 9224          | cp.intring=           | See the Installation Manual. |        |
| VM.CMG Setup | 9225          | cp.interring=         | See the Installation Manual. |        |
| VM.CMG Setup | 9226          | cp.noans=             | See the Installation Manual. |        |
| VM.CMG Setup | 9227          | onhookdtmf            | See the Installation Manual. |        |
| VM.CMG Setup | 9229          | answerack=            | See the Installation Manual. |        |
| VM.CMG Setup | 9232          | senddisconnect=       | See the Installation Manual. |        |
| VM.CMG Setup | 9256          | playbackdelay=        | See the Installation Manual. |        |
| VM.CMG Setup | 9273          | cp.disconnect=        | See the Installation Manual. |        |
| VM.CMG Setup | 9282          | qboxdataprntejct      | See the Installation Manual. |        |
| VM.CMG Setup | 9283          | qboxuseconfirmnumbers | See the Installation Manual. |        |
| VM.CMG Setup | 9289          | qboxhideacctnumbers   | See the Installation Manual. |        |
| VM.CMG Setup | 9291          | keepmessagesnew       | See the Installation Manual. |        |
| VM.CMG Setup | 9295          | pooledring=           | See the Installation Manual. |        |
| VM.CMG Setup | 9296          | mboxdefaultdigit=     | See the Installation Manual. |        |
| VM.CMG Setup | 9301          | greeting.noanswer=    | See the Installation Manual. |        |



| Task         | Param. Number | Description         | Acceptable Values            | Notes: |
|--------------|---------------|---------------------|------------------------------|--------|
| VM.CMG Setup | 9302          | greeting.busy=      | See the Installation Manual. |        |
| VM.CMG Setup | 9303          | greeting.dnd=       | See the Installation Manual. |        |
| VM.CMG Setup | 9337          | noaccountinlog      | See the Installation Manual. |        |
| VM.CMG Setup | 9339          | greeting.night=     | See the Installation Manual. |        |
| VM.CMG Setup | 9340          | faxpause=           | See the Installation Manual. |        |
| VM.CMG Setup | 9342          | samecallfaxok       | See the Installation Manual. |        |
| VM.CMG Setup | 9343          | mwonreps=           | See the Installation Manual. |        |
| VM.CMG Setup | 9344          | mwoffreps=          | See the Installation Manual. |        |
| VM.CMG Setup | 9346          | faxprefix=          | See the Installation Manual. |        |
| VM.CMG Setup | 9349          | faxgeneraldelivery= | See the Installation Manual. |        |
| VM.CMG Setup | 9351          | initialpauseidp=    | See the Installation Manual. |        |
| VM.CMG Setup | 9352          | directoryidp=       | See the Installation Manual. |        |
| VM.CMG Setup | 9353          | messagepausetime=   | See the Installation Manual. |        |
| VM.CMG Setup | 9354          | sharefaxports       | See the Installation Manual. |        |
| VM.CMG Setup | 9359          | flowcontrol=        | See the Installation Manual. |        |
| VM.CMG Setup | 9360          | fastacdtransfer     | See the Installation Manual. |        |
| VM.CMG Setup | 9361          | pmsviatextfiles     | See the Installation Manual. |        |
| VM.CMG Setup | 9364          | serviceobservecode= | See the Installation Manual. |        |
| VM.CMG Setup | 9365          | acdpause=           | See the Installation Manual. |        |
| VM.CMG Setup | 9383          | wakeuprings=        | See the Installation Manual. |        |

| Task          | Param. Number | Description   | Acceptable Values            | Notes:                 |
|---------------|---------------|---|------------------------------|------------------------|
| VM.CMG Setup  | 9384          | ivrpromptlanguage=  | See the Installation Manual. |                        |
| VM.CMG Setup  | 9388          | volume=   | See the Installation Manual. |                        |
| VM.CMG Setup  | 9389          | noserialmwrefresh   | See the Installation Manual. |                        |
| VM.CMG Setup  | 9390          | basiccptones  | See the Installation Manual. |                        |
| VM.CMG Setup  | 9392          | extrarotarytime=  | See the Installation Manual. |                        |
| VM.CMG Setup  | 9393          | transferring=   | See the Installation Manual. |                        |
| VM.CMG Setup  | 9394          | dialtonefrequency=  | See the Installation Manual. |                        |
| VM.CMG Setup  | 9395          | dialtone2frequency=   | See the Installation Manual. |                        |
| Serial Number | 4000          | Voices the system's serial number.  | —                            |                        |
| NUMLINES.TXT  | 4001          | Adjusts the code number authorizing the number of ports allowed.                            | (Code supplied by Key Voice) | Code found on invoice. |
| SWITCHES.TXT  | 4002          | Adjusts the code number authorizing the software for system features.                       | (Code supplied by Key Voice) | Code found on invoice. |
| LOGINS.TXT    | 4003          | Adjusts the code number that controls the number of VCM logins allowed.                     | (Code supplied by Key Voice) | Code found on invoice. |
| PBXLINK.TXT   | 4004          | Adjusts the code number authorizing the software for certain phone system-related features. | (Code supplied by Key Voice) | Code found on invoice. |

The following table identifies additional values you can specify to indicate special characters or information in some fields:

| Values | Indicate |
|--------|----------|
| ***1   | A        |
| ***2   | B        |

| Values | Indicate               |
|--------|------------------------|
| ***3   | C                      |
| ***4   | D                      |
| ***5   | E                      |
| ***6   | F                      |
| ***7   | Pause                  |
| ***8   | Hookflash              |
| ***0   | Clears the field entry |

### 2.7.3 Using the Teleparameter Feature to Adjust the System Setup

You can use the Teleparameter feature to adjust the system setup at any time. It is not necessary to bring down the system to make modifications. To use the Teleparameter feature to adjust information, follow steps 1 through 4 in the procedure in **section 2.7.1.2**. For specific parameters you can adjust, refer to **section 2.7.1.2**. For detailed information, refer to the *Installation and Maintenance Manual*.

**Note:** If you enter a parameter number for a parameter that affects a particular box, the system prompts you to enter the **Item number**. The Item number identifies the particular box in which you want to change the parameter. At the Item number prompt, enter the **number of the box**.

**Note:** Refer to **section 2.7.2** for information on values you can specify for certain parameters and for information on adjusting parameters in the VM.CFG file. For detailed information on each field of System Information or Box Setup screens, refer to the *Installation and Maintenance Manual*.

Be advised that many day-to-day modifications that must be made to the system (adding mailboxes, changing system greetings, making call routing modifications) can be done by calling into the supervisor mailbox and selecting options from the Supervisor menu. By using Supervisor menu options, you do not need to refer to specific parameter numbers and

values. For information on day-to-day modifications that can be made using Supervisor menu options (and not the Teleparameter feature), refer to **section 3**.

## **2.8 Upgrading 2 Port Systems to 4 Ports**

---

You can upgrade 2-port Lite systems to function as 4-port systems. Contact the Lite system sales representative for information. When you purchase a system port upgrade, you are provided a code number (located on the invoice), which you must enter into the Lite system. This code enables the additional 2 ports for service.

To enter the upgrade code, use teleparameter 4001 as described earlier in this document. When prompted, simply enter the code provided on the invoice.



## 3. System Supervisor Instructions

The procedures provided in this section indicate how a system supervisor can make changes to the system setup by calling into the system using a telephone. Each of these procedures can also be performed by accessing the Lite system software screens through a serial connection to a laptop PC. For procedures on making modifications through the screen interface, refer to procedures earlier in this document, or to the *Installation and Maintenance Manual* or *Supervisor's Guide*.

### 3.1 Working with Mailboxes

---

#### 3.1.1 Adding, Deleting, or Modifying a Mailbox

1. From a telephone, call into voice mail and log into the **supervisor mailbox 70**. The system voices the Main menu:

*“To listen to your messages press 1. To send a message press 2. To change your options press 3.”*

2. To access the Supervisor menu, **press 6** (this option is not voiced). The system voices the Supervisor menu options:

| <b>Supervisor Menu</b>                       |         |
|--|---------|
| For Mailbox Administration                   | Press 1 |
| For Routing Box Administration               | Press 2 |
| For Question Box Administration              | Press 3 |
| For Port Administration                      | Press 4 |
| To Change the System Broadcast Message       | Press 5 |
| To Change the Voice Mail Day / Night Service | Press 6 |
| To Change the System Time                    | Press 7 |
| To Change the System Date                    | Press 8 |
| To Modify System Parameters                  | Press 9 |
| To Perform First-Time Setup                  | Press 0 |

3. From the Supervisors menu, **press 1** for Mailbox Administration.
4. When prompted, **enter the number of the mailbox** you want to add, modify, or delete. The system voices the number back to you.
5. When prompted, **press 1** to confirm the number you entered or press # if the number you entered was incorrect. Once you press 1 to confirm, the system voices the Mailbox menu options:

| <b>Mailbox Menu</b> |         |
|---------------------|---------|
| To Add              | Press 1 |
| To Delete           | Press 2 |
| To Modify           | Press 3 |
| To Suspend          | Press 4 |
| To Restore          | Press 5 |
| To Reset            | Press 6 |
| To Exit             | Press # |

6. To add a new the mailbox to the system, **press 1**. The system adds the new mailbox to the mailbox database. All default settings in the mailbox are set to the default parameters settings specified in prototype mailbox 9994. The default password for the mailbox is the same as the mailbox number.

To delete the mailbox from the system, **press 2**. The system deletes the mailbox from the mailbox database.

To modify the mailbox on the system, **press 3**. The system voices the Options menu:

| <b>Options Menu</b>                          |         |
|--|---------|
| To Record Your Name                          | Press 1 |
| To Record Your Greeting                      | Press 2 |
| To Change Your Password                      | Press 3 |
| To Change Your Call-Transfer Feature         | Press 4 |
| To Change Your Message Notification Feature  | Press 5 |
| To Change Your Pager Feature                 | Press 6 |
| To Review Msgs Scheduled for Future Delivery | Press 7 |
| To Change your Personal Distribution Lists   | Press 8 |
| To Retrieve a Message Previously Sent        | Press * |
| To Return to the Main Menu                   | Press # |

7. To record the mailbox owner's name, **press 1**. (Note that each mailbox owner can also log into the mailbox and complete this task—this does not need to be performed by a system supervisor.)
8. Once you record the name, the system voices the following prompts:

|              |         |
|--------------|---------|
| To Replay    | Press 1 |
| To Re-Record | Press 2 |
| To Delete    | Press 3 |
| To Exit      | Press # |

Follow the prompts to complete the procedure.



9. To record a personal greeting for the mailbox, **press 2**. You can record up to 10 personal greetings for the mailbox (0 through 9). (Note that each mailbox owner can also log into the mailbox and complete this task—this does not need to be performed by a system supervisor.)
10. Once you record a greeting, the system voices the following prompts:

|                           |         |
|---------------------------|---------|
| To Replay the Greeting    | Press 1 |
| To Re-Record the Greeting | Press 2 |
| To Delete the Greeting    | Press 3 |
| To Choose a New Greeting  | Press 5 |
| To Exit                   | Press # |

Follow the prompts to complete the procedure.

11. To change the mailbox password, **press 3**. Note that to change the password, you must first enter the current password when prompted by the system. By default, the mailbox password is the same as the mailbox number. (Also note that each mailbox owner can log into the mailbox and complete this task—this does not need to be performed by a system supervisor.)

Once you enter a new mailbox password and confirm the entry as prompted, the system voices a prompt informing you that the new password will be in effect the next time the mailbox is accessed.

12. To change the call transfer feature, **press 4**. (Note that each mailbox owner can also log into the mailbox and complete this task—this does not need to be performed by a system supervisor.)
13. The system voices a prompt identifying the current call transfer set up, then voices the call transfer options:

|  |
|--|
| Press 1 if you would like to change the number |
| Press * to turn this feature on or off, or     |
| Press # if you are satisfied                   |

Follow the prompts to complete the procedure.

14. To change the message notification feature, **press 5**. (Note that each mailbox owner can also log into the mailbox and complete this task—this does not need to be performed by a system supervisor.)
15. The system voices a prompt identifying the current message notification setup, then voices the notification options:

Press 1 if you would like to change the number  
Press \* to turn this feature on or off, or  
Press # if you are satisfied

Follow the prompts to complete the procedure.

16. To change the pager feature, **press 6**. (Note that each mailbox owner can also log into the mailbox and complete this task—this does not need to be performed by a system supervisor.)
17. The system voices a prompt identifying the current pager set up, then voices the paging options:

Press 1 if you would like to change the number  
Press \* to turn this feature on or off, or  
Press # if you are satisfied

Follow the prompts to complete the procedure.

18. To review messages scheduled for future delivery, **press 7**. (Note that each mailbox owner can also log into the mailbox and complete this task—this does not need to be performed by a system supervisor.)

19. The system voices a prompt identifying any message scheduled for future delivery, then voices the options:

|  |         |
|--|---------|
| To Listen to the Message                                 | Press 1 |
| To Hear the Next Message (scheduled for future delivery) | Press 2 |
| To Cancel the Message                                    | Press 4 |
| To Exit  | Press # |

Follow the prompts to complete the procedure.

## 3.2 Working with Routing Boxes

### 3.2.1 Understanding the Routing Box Setup

The Lite system is pre-configured with 3 Routing boxes to process calls. Routing box 800 answers calls during office open business hours (specified as “day service” hours during set up), box 801 answers calls after day service hours, and box 821 routes calls after they have already passed through box 800 or 801.

During set up, the following greetings were recorded in Routing boxes 800, 801, and 821:

| Box | Greeting Number | Information Voiced by Greeting                  |
|-----|-----------------|---|
| 800 | Greeting 0      | Office Open greeting and call routing options   |
| 800 | Greeting 1      | Holiday greeting and call routing options       |
| 801 | Greeting 0      | Office Closed greeting and call routing options |
| 801 | Greeting 1      | Holiday greeting and call routing options       |
| 821 | Greeting 0      | Call routing options                            |

Typically, companies offer more extensive call routing options to callers during open hours than during closed hours. Often, single-digit call routing (for example, “...Press 2 for

*Sales... ”) is not offered during office closed hours, therefore the prompts and call routing options differ between box 800 and 801.*

To accommodate the fact that a holiday lasts a full 24 hours, and thus holiday calls are answered by both box 800 and 801 throughout those 24 hours, a holiday greeting is provided in both box 800 and 801.

**Box 800, Greeting 0 Example:**

*“Welcome to [Company]. If you know the extension number of the person to whom you want to speak, dial it now. For a directory, press star. Or press zero for the operator.”*

|  |
|--|
| <p><b>Note:</b> If the system is set up to provide callers single-digit call routing options (“...Press 2 for Sales...”), those options are also voiced to callers during this greeting.</p> |
|--|

**Box 800, Greeting 1 Example:**

*“[Company] is closed today for the holiday. To leave a message for a specific individual, dial the party’s extension now. For a directory, press star. If you would like to leave your message with the operator, press zero now.”*

**Box 801, Greeting 0 Example:**

*“[Company] is presently closed. To leave a message for a specific individual, dial the party’s extension now. For a directory, press star. If you would like to leave your message with the operator, press zero now.”*

**Box 801, Greeting 1 Example:**

*“[Company] is closed today for the holiday. To leave a message for a specific individual, dial the party’s extension now. For a directory, press star. If you would like to leave your message with the operator, press zero now.”*

**Box 821, Greeting 0 Example:**

*“If you know the extension number of the person to whom you want to speak, dial it now. For a directory, press star. Or press zero for the operator.”*

**Note:** If the system is set up to provide callers single-digit call routing options (“...Press 2 for Sales...”), those options are also voiced to callers during this greeting.

**Other Greetings**

Up to 10 different greetings can be recorded and stored in each Routing box. Procedures for recording additional greetings and changing the currently active greeting in each box are provided later in this section. The chart below is provided for you to note any additional greetings set up on the system:

| Box | Greeting Number | Greeting |
|-----|-----------------|----------|
|     |                 |          |
|     |                 |          |
|     |                 |          |
|     |                 |          |

### 3.2.2 Recording Routing Box Greetings or Changing Currently Active Greetings

1. From a telephone, call into voice mail and log into the **supervisor mailbox 70**. The system voices the Main menu:

*“To listen to your messages press 1. To send a message press 2. To change your options press 3.”*

2. **Press 3** to change options. The system voices the Options menu:

| <b>Options Menu</b>                          |         |
|--|---------|
| To Record Your Name                          | Press 1 |
| To Record Your Greeting                      | Press 2 |
| To Change Your Password                      | Press 3 |
| To Change Your Call-Transfer Feature         | Press 4 |
| To Change Your Message Notification Feature  | Press 5 |
| To Change Your Pager Feature                 | Press 6 |
| To Review Msgs scheduled for Future Delivery | Press 7 |
| To Change Your Personal Distribution Lists   | Press 8 |
| To Retrieve a Message Previously Sent        | Press * |
| To Return to the Main Menu                   | Press # |

3. From the Options menu, **press 2**.
4. When prompted, **enter the number of the Routing box** whose greeting you want to change.

- When prompted, **press 1** to confirm the number you entered or press # if the number you entered was incorrect. Once you press 1 to confirm, the system voices the following options, which relate to the currently active greeting:

|                           |         |
|---------------------------|---------|
| To Replay the Greeting    | Press 1 |
| To Re-Record the Greeting | Press 2 |
| To Delete the Greeting    | Press 3 |
| To Choose a New Greeting  | Press 5 |
| To Exit                   | Press # |

- If you intend to re-record the greeting, first press 1 to replay it. By replaying the greeting you can 1) ensure you are re-recording the greeting you intended to modify, and 2) note all the call routing options that are currently provided in the greeting so you can restate the appropriate call routing options in the new greeting you record (for example, "...*Press 2 for Sales...*"). Note that you can modify the single-digit call routing options by following the procedure provided later in this section.
- To re-record the greeting, **press 2**. The system prompts you to enter the number of the greeting you want to re-record. Enter the greeting number (0 through 9). Then, follow the prompts to complete the procedure.
- To choose a new greeting to play as the currently active greeting, **press 5**. The system prompts you to enter the number of the greeting you would like to activate or to press star for the currently active greeting. If you press \*, the system voices the currently active greeting number and greeting, then re-voices the options:

|                           |         |
|---------------------------|---------|
| To Replay the Greeting    | Press 1 |
| To Re-Record the Greeting | Press 2 |
| To Delete the Greeting    | Press 3 |
| To Choose a New Greeting  | Press 5 |
| To Exit                   | Press # |

- Once you press 5 and enter a new greeting number, the system voices a confirmation prompt stating the greeting number and voicing the now-active greeting.

### 3.2.3 Changing the Single-Digit Call Routing

The Lite system can be set up to voice greetings to callers that include single-digit call routing options, such as, “*Press 2 for Sales...*” On a system set up this way, a call is transferred to a certain mailbox when the caller presses 2 during or after the greeting. You can control the digit(s) callers can dial and the route their calls will subsequently take using the following procedure.

Note that if you use the following procedure to change the single-digit call routing set up, you must update the Routing box greeting to relay new instructions to the caller. Use the procedure in **section 3.2.2** to update the greeting as necessary.

1. From a telephone, call into voice mail and log into the **supervisor mailbox 70**. The system voices the Main menu:

*“To listen to your messages press 1. To send a message press 2. To change your options press 3.”*

2. To access the Supervisor menu, **press 6** (this option is not voiced). The system voices the Supervisor menu options:

| <b>Supervisor Menu</b>                       |         |
|--|---------|
| For Mailbox Administration                   | Press 1 |
| For Routing Box Administration               | Press 2 |
| For Question Box Administration              | Press 3 |
| For Port Administration                      | Press 4 |
| To Change the System Broadcast Message       | Press 5 |
| To Change the Voice Mail Day / Night Service | Press 6 |
| To Change the System Time                    | Press 7 |
| To Change the System Date                    | Press 8 |
| To Modify System Parameters                  | Press 9 |
| To Perform First-Time Setup                  | Press 0 |
| To Exit                                      | Press # |

3. From the Supervisors menu, **press 2** for Routing box Administration.
4. When prompted, **enter the number of the Routing box** with which you want to work.



- When prompted, **press 1** to confirm the number you entered or press # if the number you entered was incorrect. Once you press 1 to confirm, the system voices the Routing Box administration menu options:

| Routing Box Menu |         |
|------------------|---------|
| To Add           | Press 1 |
| To Delete        | Press 2 |
| To Modify        | Press 3 |
| To Exit          | Press # |

- To make modifications to the Routing box, **press 3**. The system voices the modification options:

|                        |         |
|------------------------|---------|
| To Change the Greeting | Press 1 |
| To Change the Routing  | Press 2 |
| To Exit                | Press # |

- To change the routing structure, **press 2**. The system voices the prompt, *“For digits zero through nine, please enter the digit, or press \* for special routing options.”*
- Press the digit** for which you want to modify the call routing. The system voices a prompt identifying the current call routing set up for the digit.
- When prompted, **press 1** to change the routing for the digit. Then, when prompted, enter the number of the box to which you now want callers who press the digit to route. The system voices a prompt stating the new call routing structure.

Note that you can make special call routing refinements by pressing \* in step 8 above. The system voices the following special routing options:

|   |         |
|---|---------|
| To Change the Destination for the Star Digit  | Press * |
| To Change the Destination for the Pound Digit | Press # |
| To Change the No Digits Destination           | Press 1 |
| To Change the Invalid Digit Destination       | Press 2 |
| To Change the Voice Detected Destination      | Press 3 |

Once you access this menu, be advised that you must not press # to exit it, since the # key invokes a change to the destination for the pound key. If you want to return to the previous menu, simply make no entry when you hear the special routing options prompt.

## 3.3 General System Maintenance

### 3.3.1 Enabling or Disabling a Port

1. From a telephone, call into voice mail and log into the **supervisor mailbox 70**. The system voices the Main menu:

*“To listen to your messages press 1. To send a message press 2. To change your options press 3.”*

2. To access the Supervisor menu, **press 6** (this option is not voiced). The system voices the Supervisor menu options:

| <b>Supervisor Menu</b>                       |         |
|--|---------|
| For Mailbox Administration                   | Press 1 |
| For Routing Box Administration               | Press 2 |
| For Question Box Administration              | Press 3 |
| For Port Administration                      | Press 4 |
| To Change the System Broadcast Message       | Press 5 |
| To Change the Voice Mail Day / Night Service | Press 6 |
| To Change the System Time                    | Press 7 |
| To Change the System Date                    | Press 8 |
| To Modify System Parameters                  | Press 9 |
| To Perform First-Time Setup                  | Press 0 |
| To Exit                                      | Press # |

3. From the Supervisors menu, **press 4** for Port Administration.
4. When prompted, enter the **number of the line** with which you want to work.

- When prompted, **press 1** to confirm the number you entered or press # if the number you entered was incorrect. Once you press 1 to confirm, the system voices the port administration options:

|                   |         |
|-------------------|---------|
| To Disable a Port | Press 1 |
| To Enable a Port  | Press 2 |
| To Exit           | Press # |

- To shut down a port, **press 1** to disable it. If you disable a port, all calls using that port are immediately terminated.
- To enable a port that is currently shut down, **press 2**.

### 3.3.2 Recording a Broadcast Message for All Mailboxes

A broadcast message is automatically sent to every mailbox on the system. The message is played to the mailbox owners the first time they log into their mailbox following the recording of the broadcast message. A broadcast message does not activate any message waiting lights or indicators on subscriber telephones and does not add to the message count of new or old messages in subscriber mailboxes.

- From a telephone, call into voice mail and log into the **supervisor mailbox 70**. The system voices the Main menu:

*“To listen to your messages press 1. To send a message press 2. To change your options press 3.”*

- To access the Supervisor menu, **press 6** (this option is not voiced). The system voices the Supervisor menu options:

| <b>Supervisor Menu</b>                       |         |
|--|---------|
| For Mailbox Administration                   | Press 1 |
| For Routing Box Administration               | Press 2 |
| For Question Box Administration              | Press 3 |
| For Port Administration                      | Press 4 |
| To Change the System Broadcast Message       | Press 5 |
| To Change the Voice Mail Day / Night Service | Press 6 |
| To Change the System Time                    | Press 7 |
| To Change the System Date                    | Press 8 |
| To Modify System Parameters                  | Press 9 |
| To Perform First-Time Setup                  | Press 0 |
| To Exit                                      | Press # |

- From the Supervisors menu, **press 5** for System Broadcast Message. The system voices the following options:

|                                       |         |
|---------------------------------------|---------|
| To Hear the Current Broadcast Message | Press 1 |
| To Re-record the Broadcast Message    | Press 2 |
| To Delete the Broadcast Message       | Press 3 |
| To Exit                               | Press # |

- To record a broadcast message, **press 2**. Follow the prompts to complete the procedure.

### 3.3.3 Transferring a Caller to a Mailbox's Voice Mail

Use the following procedure to transfer a caller directly to a mailbox, without having the system attempt to ring the mailbox's associated extension.

- Press the **TRANSFER** key on the telephone.

2. Dial the number for voice mail or press the voice mail hotkey.
3. Dial the **number of the mailbox** to which you want to transfer the call.
4. To divert the call directly to the mailbox's voice mail, press \*.
5. Hang up the telephone.

### **3.3.4 Troubleshooting System Problems**

Follow these guidelines to effectively report problems you may encounter:

**Gather as much detail concerning the situation as possible:**

- Time and date the problem occurred.
- Box and extension number(s) affected.
- Action immediately preceding problem.
- Action taken since problem occurred.

**Attempt to duplicate the problem:**

- Note the actions taken that apparently invoke the problem.
- Recall any recently made system set up changes that may be contributing to or causing the problem.
- Attempt to duplicate the problem. If you cannot duplicate the problem, it may be have been attributed to user error.