

Table of Contents

| | |
|---|-----------|
| INTRODUCTION..... | 2 |
| ASSUMPTIONS..... | 3 |
| CALL CENTER OVERVIEW | 4 |
| ACD SYSTEM OVERVIEW | 6 |
| CALL CENTER OPERATION..... | 8 |
| <i>SMDR Records.....</i> | 9 |
| <i>ACD Real-time Event Records.....</i> | 9 |
| CALL DISTRIBUTION - LONGEST IDLE AGENT | 10 |
| ACD MIS SYSTEM..... | 11 |
| RECORDED ANNOUNCEMENT DEVICES | 11 |
| WALL SIGN | 11 |
| CALL CENTER PERFORMANCE OBJECTIVES | 12 |
| PERFORMANCE TARGETS | 12 |
| <i>Revenue-based Call Centers.....</i> | 12 |
| <i>Cost-based Call Centers.....</i> | 12 |
| TASKE ACD TOOLBOX OVERVIEW..... | 14 |
| THE TASKE VIEW OF SERVICE..... | 14 |
| <i>TASKE Historical Reports.....</i> | 14 |
| <i>TASKE Real-time Displays.....</i> | 15 |
| TASKE ACD TOOLBOX: COMPONENTS..... | 16 |
| <i>TASKE Data Collector</i> | 16 |
| <i>TASKE Administrator.....</i> | 16 |
| <i>TASKE Search</i> | 17 |
| <i>TASKE Reports</i> | 17 |
| <i>Traffic Analyzer</i> | 18 |
| <i>TASKE ACD Monitor.....</i> | 18 |
| <i>TASKE WallSign Administrator.....</i> | 19 |
| <i>TASKE Agent Desktop.....</i> | 19 |

Introduction

Welcome to the TASKE ACD ToolBox, a collection of Microsoft Windows based tools and utilities that enable the manager to analyze the performance of the ACD Call Center, and fine tune its operation.

These tools and utilities operate on the Mitel SX-200 PBX, and are accessed through the TASKE ToolBox v7 folder, as illustrated below. Within the ToolBox folder, each icon represents a program in the ToolBox; each program provides the functionality for a particular aspect of ACD Call Center management.



This manual provides an overview of:

- the components and operation of the ACD Call Center,
- telephone traffic and service criteria,
- Call Center management, and
- networking.

Additionally, this guide describes and explains how each of the ACD ToolBox programs work, and how each applies to Call Center management.

Assumptions

A working knowledge of ACD Call Center technology is essential for the operation and use of the TASKE ACD ToolBox. Many of the common Call Center terms and assumptions are discussed in this guide. To ensure efficient use of all of the tools in the TASKE ToolBox, it is assumed the terms and concepts discussed in this guide are read and understood. Refer to the documentation for the telephone system to provide additional background material necessary to use the TASKE ToolBox properly.

The Installation Guide is provided to ensure a correct install is performed for both Supervisor (Client) and Server installs.

To access the online help for any TASKE ToolBox application, choose the Help option from the Help menu within the application, or press the F1 key on the keyboard while the application is running.

Each application in the TASKE ToolBox has a user guide accessed by opening the Welcome.pdf file in the taske\docs directory.

Call Center Overview

ACD

ACD is an acronym for Automatic Call Distribution. The term ACD Call Center refers to any PBX that handles many telephone calls of a similar nature. Within an ACD Call Center, agents with similar skills are grouped into Agent Groups for the purpose of routing specific calls to the appropriate group with the relevant information. ACD call operations may be set up with many groups of agents who are common to departments such as Sales, or Customer Service, where a group of employees respond to similar queries. As all Agents within a group are answering calls of a similar nature, it does not matter which Agent answers a particular call; calls are received and distributed amongst the available Agents.

ACD Terms

An ACD Call Center is illustrated below. The Central Office (CO) directs call attempts to the PBX. Call attempts that find an available Trunk, and an available agent are answered immediately. When a call is Answered by an Agent it enters a Talk Time period. After completing a call the Caller disconnects but the Agent may have to complete associated paperwork. This period of time is called Work Time.

Those Callers who find a Trunk but then find no one immediately available to talk to them, must wait in Queue for an available Agent. While in Queue, Callers can receive messages from a Recorded Announcement Device (RAD). Of the calls waiting in Queue, most are answered by an Agent but some proportion Abandon the call before it is Answered.

CALL CENTRE OVERVIEW

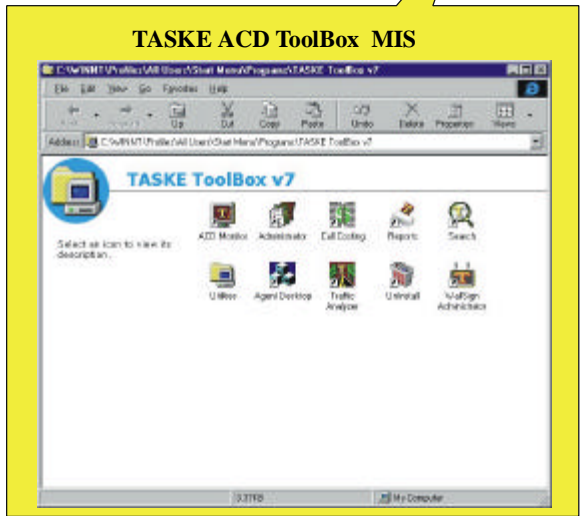
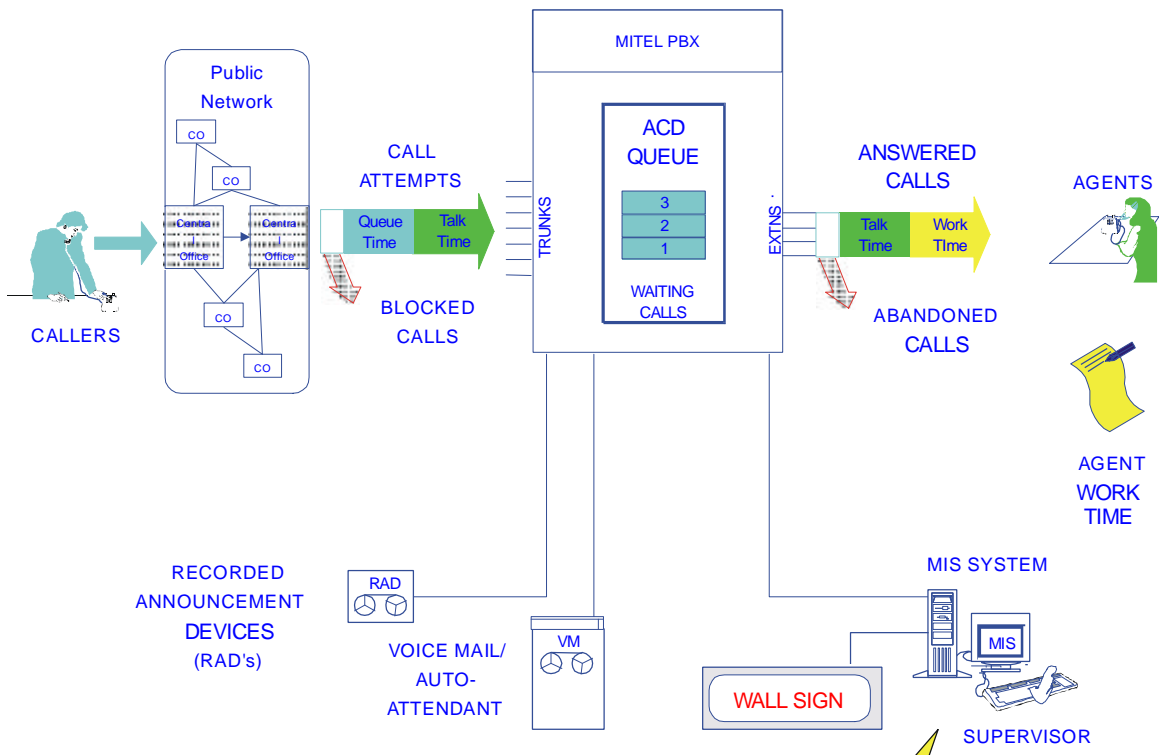

Purpose of ACD

An ACD Call Center accepts incoming calls and distributes them to a group of Agents in a manner that ensures the calls are processed at minimum cost but with acceptable service to Callers. To accomplish this requirement, the Telephone System manages call handling using an Automatic Call Distribution (ACD) process. ACD is a specialized PBX application for rationing incoming calls, where the normal situation is to expect more incoming calls than can be answered immediately.

ACD System Overview

As mentioned previously, the purpose of a Call Center is to handle large volumes of calls as efficiently as possible, and at minimum cost. To achieve this objective calls are distributed to Agents without regard to which Agent handles which call. The Agents are specifically trained to respond to one or more category of calls; during busy periods calls may be transferred between Agent Groups, as illustrated on the next page.

ACD Agent - ACD Log In/Log Out

The Agent is defined by an Agent ID (Agent Identifier) when using an Extension as an ACD station. The Agent using the Extension is represented as an Agent ID. When entering the Agent ID into the system, the Agent effectively logs into the Call Center. This is a signing on process, which activates the Extension as an ACD position. At the end of a work shift, the Agent signs off, or logs out, of the Call Center. A group of Agents responsible for answering ACD calls to an ACD Queue is referred to as an Agent Group.

ACD Queue

In a Call Center, incoming calls are placed in an ACD Queue. If the number of incoming calls that arrive exceeds the number of available Trunks, then the Callers are given a busy signal. Thus, the number of Trunks determines the ACD Queue size, and this in turn determines the total number of calls that can be handled at any given point in time.

If all Agents are busy, calls are held in the ACD Queue. This is the purpose of the ACD Queue. It allows the Caller to wait for an answer rather than being Blocked from entering the PBX, and having to repeatedly re-dial the number to find a free Agent.

ACD SYSTEM OVERVIEW

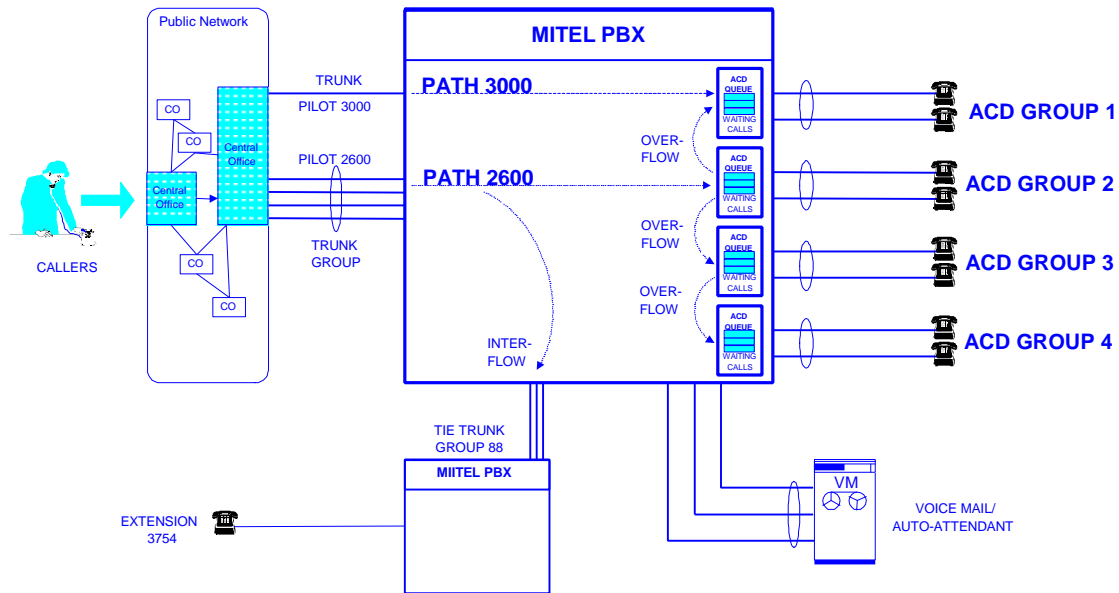
**Overflow**

The Agents in a Call Center may be trained to handle calls for other Groups. For example, Customer Service personnel might be trained to answer calls for the Sales department during busy periods. One of the special features of the ACD Function is the ability to Overflow from one Agent Group to another.

An ACD call that cannot be answered immediately is placed in an ACD Queue. After a pre-determined time (the Overflow time) the call can also be placed in the ACD Queue of a second Agent Group. This increases its chances of being answered quickly. In this case the call is Overflowed from one Queue to another. Thus, Overflow is a mechanism which, after a threshold time, either:

- takes a call from one Queue and places it in a second Queue (ACD-1); or
- adds the call to a second Queue in addition to keeping its place in the first Queue (ACD-2).

The primary purpose of the Overflow feature is to limit the potential delay faced by Callers who might otherwise have a relatively long wait.

Interflow

If a Caller waits a particularly long time and the call is still not answered (it is still in one or more Queues) then it may be preferable, from the Caller's perspective, to be taken out of the Queue(s) and given alternative treatment. This process is termed Interflow in the Mitel ACD systems. For example, an ACD call may have been delayed for 10 minutes in Queue. By this point in time, the Caller's patience has probably run out. It may then be desirable to re-direct the Caller to a Voice Mail system to leave a message and have an Agent place a call back to that person. In this example, the call would interflow from the ACD system to the Voice Mail system. The call may interflow to Voice Mail, to another ACD queue with a higher priority, to another Extension answering point, to a Trunk route, to a RAD Device, or even to another PBX.

Path

A Path contains the information necessary to control an incoming call through the ACD system. It specifies the resources, the order in which the calls are encountered, and the timing of the steps. All the options for a specific Path are entered in the Path Assignment form on the SX-200.

Call Center Operation

Within an ACD Call Center, if there are more Agents than calls needing to be answered, then the Agents are idle for part of the time and costs increase. Therefore, in most cases, ACD Call Centers are designed so that at any given time the number of available Agents is less than the number of waiting calls. This helps to define the number of Agents that are required for a Call Center.

Acceptable Service

If there are more calls than can be answered by the Agents, then Callers must be kept waiting for an Agent to become free. Therefore, there is a minimum number of Agents required if the service to Callers is to be acceptable. In between these upper and lower limits there is a balance, where a given number of Agents provide satisfactory service at a minimum cost; the objective of Call Center management is to achieve a good balance.

Forecasting

For the Forecasting process, the call volumes and patterns from current and past calls are identified using Historical Reports. These patterns are then used to predict expected call volumes and call patterns for future work shifts. From the expected call volumes and patterns, and with the

service level targets applied, the number of Trunks and Agents required for an ACD Queue can be estimated.

Historical Reports

The process of estimating projected traffic levels is termed forecasting. The analysis of past levels is derived from Historical Reports produced by the ACD ToolBox, and is based on the Station Message Detailed Reporting (SMDR) data generated by the PBX. Historical Reports provide statistics on the characteristics of the calls that are received, such as the number of calls per half-hour, and the duration of the calls.

SMDR Records

Station Message Detail Recording (SMDR) is a data stream generated by the PBX, which provides details of where calls went, who answered them and for how long the call was engaged. The SMDR records are generated by the PBX at the end of a call or call segment. A call can produce multiple SMDR records if it is transferred or if Account Codes are entered while the call is active. The information that is provided includes: the start time of the call, the duration of the call, who started the call, and who the answering party was. External SMDR records are initiated every time an incoming or outgoing trunk is seized. At the same time, the called data is collected on a per-call basis, formatted into an SMDR Record and routed to an RS-232 port for processing. Internal SMDR records provide information about calls that are placed from station-to-station, but are not generated for calls that involve trunks.

ACD Real-time Event Records

The PBX generates ACD Real-time Event records; the MIS uses these to produce information on the current status of the ACD Queue(s). The ACD Real-time Event records generated include:

- 'Call Activity' event records, which describe significant call routing activities; and
- 'Agent Activity' event records, generated in response to Agent activities such as logging in.

Immediately when an action is performed or an event occurs, the MIS generates data on the current status of the ACD Queue; the MIS provides status reports in 'real time'.

ACD Real-time Event records are used to provide a current view of Call Center operations via the Real-time ACD Monitor. The ACD Monitor provides information such as the current status of Agents and current call handling parameters.

The ACD Real-time Event stream contains records that are generated immediately when an Agent enters a new call state (such as Idle or Answering ACD Call), and immediately when an Agent activates a feature (such as Log In or Log Out). Agent events are reported whenever an Agent connects to a Caller, regardless of whether or not an external Trunk is involved in the call.

Supervision

The second major challenge in the ACD environment is adjusting the balance between the number of calls received and the number of available Agents. In general terms, this is the supervision process of monitoring and managing Call Center operations in real-time. This can be approached by several means including:

- reducing the number of calls that are accepted;
- increasing the number of available Agents; and
- reducing the time per call so that the same number of Agents handle more calls.

Work Time

If an Agent uses a Work Time period at the end of a call for performing associated paper work, then the duration of time that the Agent is involved in the call can be more than that of the Trunk. When an Agent is on Work Time, the Agent's line appears unavailable and a new call cannot be distributed to it. However, Work Time does not tie up the Trunk, which is free to accept another call as soon as the Caller disconnects. This means the Trunk can sometimes handle more calls than the Agent(s) (depending on how long Callers spend waiting in Queue).

ASA

The Average Speed of Answer is the average number of seconds it takes to answer a call in an ACD Queue, by a non-Announcement Device.

Call Distribution - Longest Idle Agent

An additional problem for ACD Call Centers is ensuring the equitable distribution of calls amongst Agents. For a Group of employees in similar job positions, there should be an equitable distribution of the workload so that employee morale is not adversely affected.

Call Centers can employ a call distribution process that is termed the Longest Idle Agent. The system tracks all calls to all Agents and forwards the next

incoming call to the Agent who has been idle the longest. The effect of this is that, even over a relatively short period of time, the call load distribution is approximately even.

ACD MIS System

The MIS provides the information that helps the ACD Supervisor control and manage the system. The term ACD Supervisor is used to describe the personnel and functions that are needed to control and manage an ACD Call Center. Some functions include: the ability to access MIS information, the ability to control call routing, and the ability to control available Agent resources.

Recorded Announcement Devices

An automatic message system is used to improve Callers' tolerance of Queue delays. A recorded message(s) informs Callers that their call has been received and will be answered in order of arrival. This encourages the Caller to wait, providing reassurance the call has reached the right number and that the delay will be limited.

Wall Sign

A Wall Sign may be used to inform Supervisors and Agents about the current status of an ACD Queue. A Wall Sign is an electronic sign board connected to a controlling device, such as a PC, and displays information provided by the TASKE system.

Wall Signs can be used to display many ACD performance parameters such as the number of daily calls handled and the level of service provided to Callers. Wall Signs can also be used by Supervisors to display congratulatory ("Well done!"), encouraging ("Speed up!") and warning ("Calls are backing up!") messages.

Typically, the Wall Sign is used to indicate the number of Calls Waiting and/or the Average Speed of Answer. If these parameters increase to a level where performance targets are not being met, then Agents and Supervisors should respond by attempting to handle calls more efficiently. The Supervisor may be able to log in additional Agents and/or the Agents may be able to shorten the call Talk Time to handle more calls.

Call Center Performance Objectives

Performance Targets

In order to ensure consistent service, the Call Center should adhere to some pre-defined targets for performance in terms of the level of Blocking, and Queue delay characteristics. This ensures that the telephone traffic, the number of Trunks and the number of Agents are kept in balance. The objective is to achieve the performance targets specified by the organization, and at minimal cost.

The performance targets should be appropriate to the function of the Call Center. In this respect, incoming Call Centers may be broadly divided into two categories: Revenue-based and Cost-based Call Centers.

Revenue-based Call Centers

In revenue-based Call Centers each call has value in terms of the net revenue per call. For example, by tracking call and sales statistics, a catalog sales operation can estimate the average revenue per call. The objective in this type of Call Center is to provide a very high level of service with few Blocked calls and minimal delays. Otherwise, the Caller may go to the competition and the organization loses revenue. Thus, the Call Center must balance average call answering costs against average per call revenues.

The objective is to receive as many calls as possible at the maximum net revenue, or profit, per call. The Call Center's net revenue is the gross sale price less the cost of goods and shipping, and less the cost of call handling. In order to ensure minimum handling costs per call, the Call Center does not attempt to handle every single call; marginal calls may cost more in additional Agent costs than the revenue generated by the last few calls that Abandon. The Call Center constantly monitors lost calls to identify the number of these per shift. When the lost revenue from calls not handled exceeds the cost of an additional Agent, then the Call Center will hire another Agent.

Cost-based Call Centers

In a cost-based Call Center, ACD Queuing is often employed in the customer support and service provision categories where a cost is incurred for each call to the organization. The call handling incurs costs but does not result in additional revenue. The costs to the organization include the cost of handling the call and the cost of providing the support service (or the research to examine a Caller's particular problem). Ideally, there would be no calls, and thus no cost to the organization. However, if the support service was not provided, there would be a short term savings to the organization but a long term loss in business as clients migrate to organizations providing support.

The level of service in a cost-based Call Center is generally not as good as that for a revenue-based Call Center; this is typically manifested as relatively little chance of Blocking but an almost certain delay of considerable length. In fact, it would appear that many such support lines are programmed to ensure a minimum delay; it is often the intent of an organization to force Callers to listen to information on-hold. Generally, an organization provides information on problems that are typically encountered with their product(s), with the expectation that Callers will obtain some clues and resolve their problems without requiring the assistance of a live Agent.

In these circumstances, the Call Center must find a balance between perfect service and the cost of providing the service; if it wishes to lower costs then service gets worse (in terms of the answering time and probability of getting a busy signal). In essence, the balance is between complaints that the organization spends too much money, and complaints that the organization provides poor service.

The length of delay is generally a balance between long distance and manpower costs, and the long-term impact of potential lost business.

Note For 1-800 calls, the waiting time spent in Queue is a cost to the organization and the chargeable time starts when the call enters the ACD Queue and not when the Agent answers the call.

TASKE ACD ToolBox Overview

The TASKE View of Service

The TASKE ACD ToolBox MIS provides Historical Report and Real-time display capabilities for all operations that are performed by the MITEL SX-200 DIGITAL system, enabling a review of the performance of ACD and NonACD elements.

TASKE Historical Reports

Historical Reports provide the following accounts of long-term activity.

| | |
|----------------------------------|---|
| Customer perception of service: | Pilot and Pilot Group Reports |
| Agent activity and productivity: | Agent and Agent Group Reports |
| System and equipment activity: | Trunk, Trunk Group, Extension and Extension Group Reports |
| Call types (optional): | Pilot and Pilot Group Call Reason Reports |

Pilot and Pilot Group reports provide a view of the operation of the Call Center as seen by the Caller. Information is collated on service parameters and call activity including: the Service Percentage (or the chance of being Answered before Abandoning), the length of time a Caller waits before Abandoning, and whether the Call is Answered by an Agent or is recalled to an alternate answering point.

Agent and Agent Group reports provide a view of the operation of the Call Center as seen by the Agent. Information on call parameters and resource activity, such as the number of NonACD calls that are Answered by an Agent(s) and the percentage of time that an Agent is talking to Callers, is compiled.

Trunk, Trunk Group, Extension and Extension Group reports provide an indication of how ACD equipment is used. Information pertaining to the percentage of total time spent on incoming and outgoing calls for a particular Extension or Group, is compiled.

Pilot and Pilot Group Call Reason reports provide a detailed view of call handling. By analyzing Agent Account Codes, a view may be obtained of the type of calls that are handled.

Account Codes are strings of digits that Agents enter into the ACD system to indicate a particular category of call. For example, if an Agent in an office supply business receives an order for a stapler, the code 1588 might be entered, where 15 is used to indicate stationery products and 88 to indicate staplers. The

business can then track how many calls were received for various departments and products.

The MIS collates call records by Account Code and reports call details for each code, such as the total number of calls and the relative usage of a given code when compared to all codes. This enables the business to identify which departments and products are generating the most, or the least, number of calls.

TASKE Real-time Displays

The VT100 based Mitel DIGITAL Monitor and TASKE ACD Monitor Real-time displays provide the Supervisor with a snapshot of Agent and Pilot activity. Real-time Displays focus on short term activity and provide the following current and recent views.

Now and Current Status

Now is the current status of Agents via Pilot/Path or Pilot Groups. The Real-time Display provides a view of the current status or recent activity of the ACD operation based on the latest available information. For displays that focus on the current status, information such as the number of Idle Agents and the number of Agents handling ACD and NonACD calls, is provided.

LastHour

LastHour is the activity for the last hour via Pilot/Path or Pilot Groups.

Last12Hours

Last12Hours is the activity for the last 12 hours via Pilot/Path or Pilot Groups.

LastHour or Last12Hours

For displays that focus on the last hour or the last twelve hours, a view is provided for a given Pilot or Pilot Group of information on: the Average Abandon Time, the Average Speed of Answer, the Service Percentage, the Telephone Service Factor and the number of Calls Waiting.

TASKE ACD ToolBox: Components

The TASKE MIS system includes the tools illustrated below.



TASKE Data Collector

The TASKE Data Collector program runs in the background and is not readily apparent to the user. The TASKE Data Collector is a program that interfaces with the telephone system and collects call center data. This data consists of SMDR and Real-time Event records. To ensure efficient use of the hard disk, the TASKE Data Collector compresses the records.

TASKE Administrator



The TASKE Administrator contains these functions:

The Administrator program is used to establish and modify (when required) the TASKE system's Administrator so that it meets the configuration requirements for: Agents and Agent Groups, Extensions and Extension Groups, Pilots/Path and Pilot Groups and Trunks and Trunk Groups. The Administrator program drives the Historical Reporting functions and is located on a non-volatile hard disk medium. The Administrator tells the TASKE system which devices are required for the Historical Reports.

The TASKE Administrator includes the maintenance functions:

- Disk Audit - indicates when available disk space is running low

- Shadow Drive Support - to make a backup of records as protection against a network crash
- Error logs - track and report any errors encountered by the TASKE system
- Disk Utilization - provides statistics on disk usage
- Archive Records – provides for the automatic archiving of older records to ensure there is always free space for new records
- Delete Old Records - provides for the automatic deletion of old records to ensure there is always free space for new records
- Alarm Setting – allows alarms to be set to notify if the collector stops receiving data.

TASKE Search



TASKE Search contains these functions:

The Search program enables Supervisors to extract particular data records for closer review. Typical Call Center activity generates very large volumes of data records. The Supervisor may wish to examine specific categories of records. The TASKE Search tool narrows down the search.

TASKE Reports



TASKE Reports contains these functions:

A series of "Reports" can be created for the following time periods:

- Daily Reports for reports for a single day's Telephone system operations.
- Weekly Reports for reports for a seven day period of Telephone system operations.
- Monthly Reports for reports for a calendar month of Telephone system operations.
- YearToDate Reports for reports by week for several weeks of Telephone system operations.
- YearByMonth Reports for reports by month for several months of Telephone system operations.

Reports can also be generated in the TASKE Reports program by Agent, Pilot, Extension or Trunk.

Templates for commonly run reports can be saved and reused in the TASKE Reports program.

TASKE Reports also includes a Forecasting function to determine the resources needed for the Call Center, and is based on either hypothetical parameters (input via the keyboard), or on parameters derived directly from TASKE Historical Reports. This utility estimates the number of required Agents, the number of calls that can be handled for a given period, and the maximum Talk Time.

Any reports created in the TASKE Reports program can be viewed on screen, printed or exported to another data file type.

Traffic Analyzer

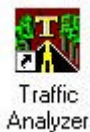

The Traffic Analyzer program is a traffic engineering utility which enables traffic estimates to be performed on Trunk, Queue and Agent resources and performs calculations via the Erlang B, Erlang C and Poisson formulae. It also enables the calculation of estimates for the following traffic parameters: the number of Trunks, the level of traffic, the Grade of Service, the average delay and the number of Agents. Parameters are input via the keyboard.

TASKE ACD Monitor



The TASKE ACD Monitor contains these functions:

The ACD Monitor program provides a display of real-time information based on the present status and operation of the ACD Call Center. ACD Path numbers represent the ACD Agents directly related to the Path. This program is a key tool that enables Supervisors to manage the ACD Call Center. It provides information on the status of Agents and Pilots. Pilots may be combined to form Pilot Groups, enabling the Supervisor to monitor combined segments of the ACD system.

The TASKE ACD Monitor program provides a replay interface for the playback of historical Call Center performance information in both graphic and text form. Event records stored in ACD system files can be replayed allowing Supervisors to view Call Center activities as they happened.

TASKE WallSign Administrator



TASKE WallSign Administrator contains these features:

The TASKE WallSign Administrator programs allow selection and display of various messages and ACD information on one or more Wall Signs. The WallSign Machine is the engine that drives the Sign Network; in its running state, it analyzes and executes the Sign Plans defined in the Configuration program. The TASKE WallSign Machine receives performance updates, every second, on the Real Time Database variables specified with the current running message.

The TASKE WallSign defines, tests, and saves Conditional and Default Messages displayed on the Wall Signs of the Sign Network.

The TASKE WallSign Quick Message function displays a brief message before, during, or in place of a message defined in a Sign Plan.

The TASKE WallSign Graphics Wizard function allows custom designed graphics to be produced (like company logos) for display on the Wall Signs.

TASKE Agent Desktop



The TASKE DeskTop Sign displays both user-specified real-time and historical statistics on the status of Agents, and also ACD performance parameters. The statistics are displayed in color-coded subdivisions on desktop screens, and are continuously updated as new data is received from the TASKE Data Collector.